

**PRELIMINARY IMPROVEMENT PLAN**

SE 54TH COURT

TRACT 'A'

SE 54TH AVENUE  
(PUBLIC)

**W.B. WELLS  
& Associates, Inc.**  
ENGINEERS-SURVEYORS-PLANNERS  
4230 NE FREMONT STREET  
PORTLAND, OREGON 97213  
PHONE: (503) 284-5886 FAX: (503) 284-8530  
e-mail address: info@wbwells.com



**PRELIMINARY IMPROVEMENT PLAN  
TAX LOT 1500**

FOR  
**CHARLES CLARK  
MILWAUKIE, OREGON**

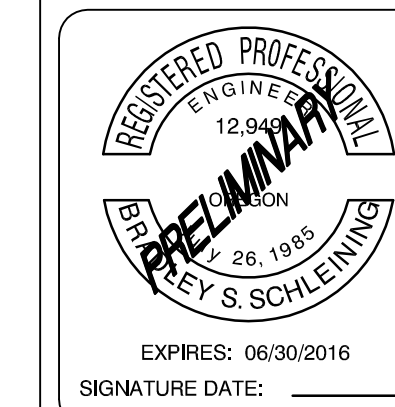

**PACIFIC DESIGN NW  
CHARLES CLARK**  
P.O. BOX 22208  
Milwaukie, OR 97269  
503-789-0067

REVISIONS:

DESIGNED BY: LKF  
DRAWN BY: LKF  
CHECKED BY: BSS  
FILE ID: 15-127-PLANNING  
PLOT DATE: 11-06-15  
JOB NO: 15-127

© W.B. WELLS 2005

SHEET 3 OF 4

Drawing Name: P:\Data\_Share\15-127\DRAWINGS\15-127-PLANNING.dwg Nov 18, 2015 - 1:55pm - lkmcf

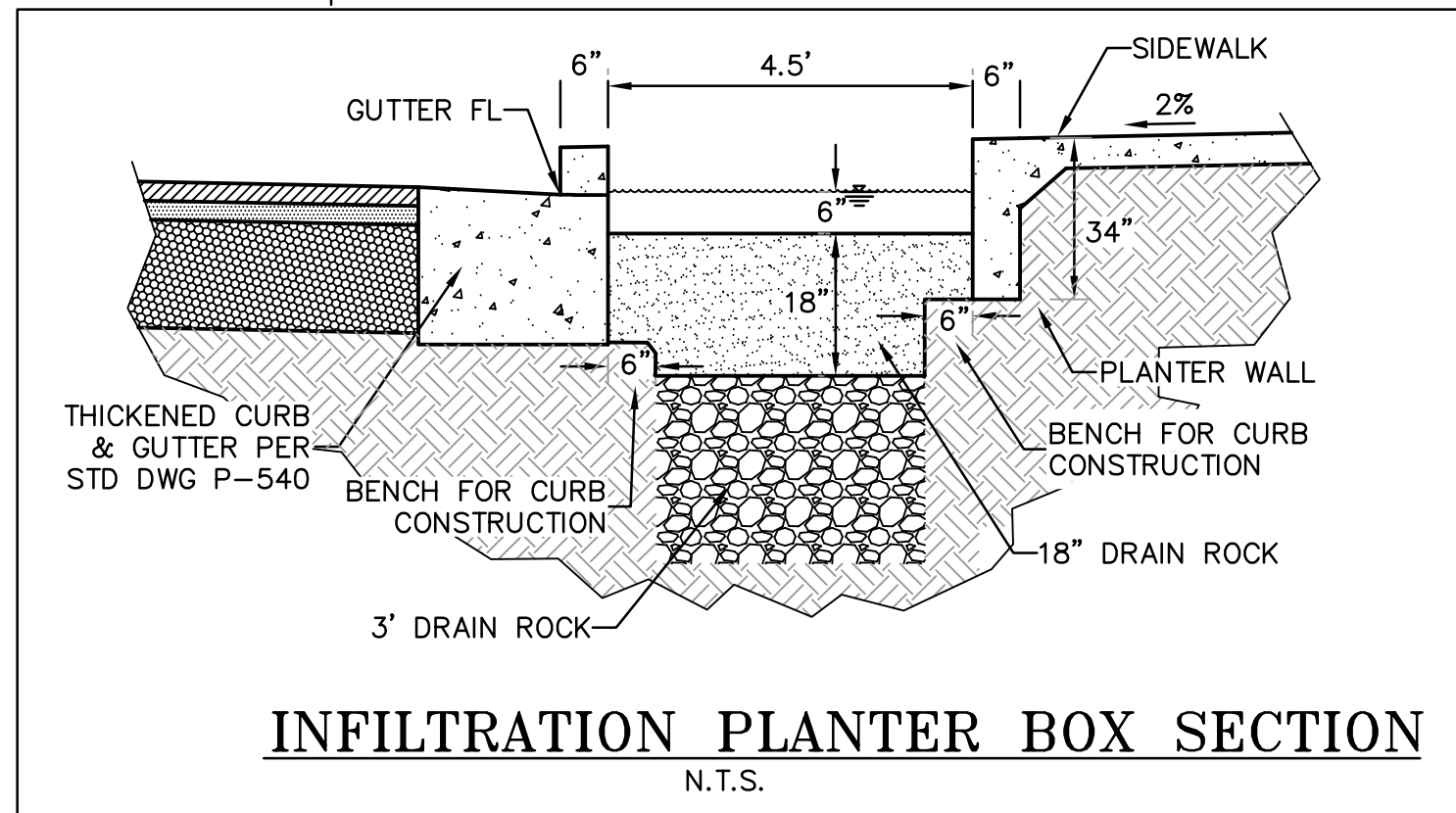
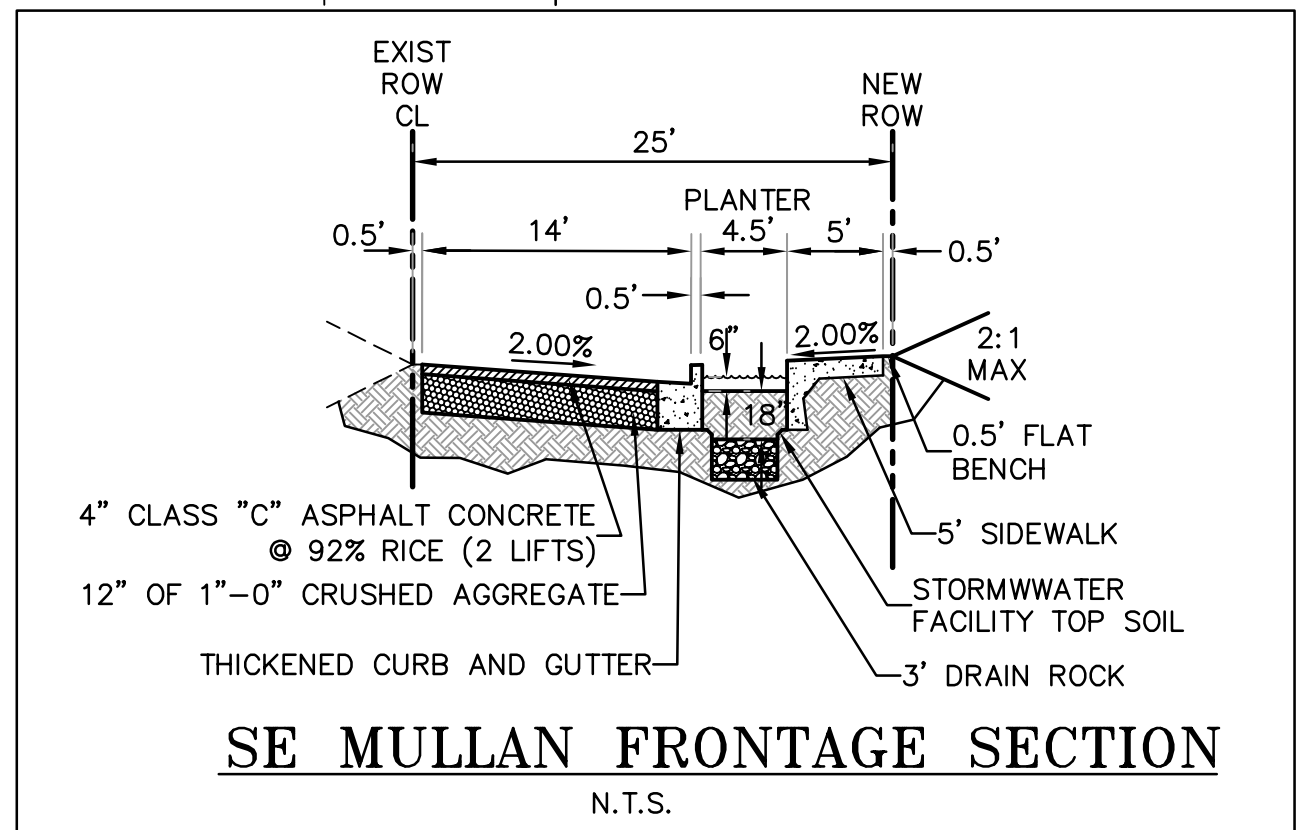
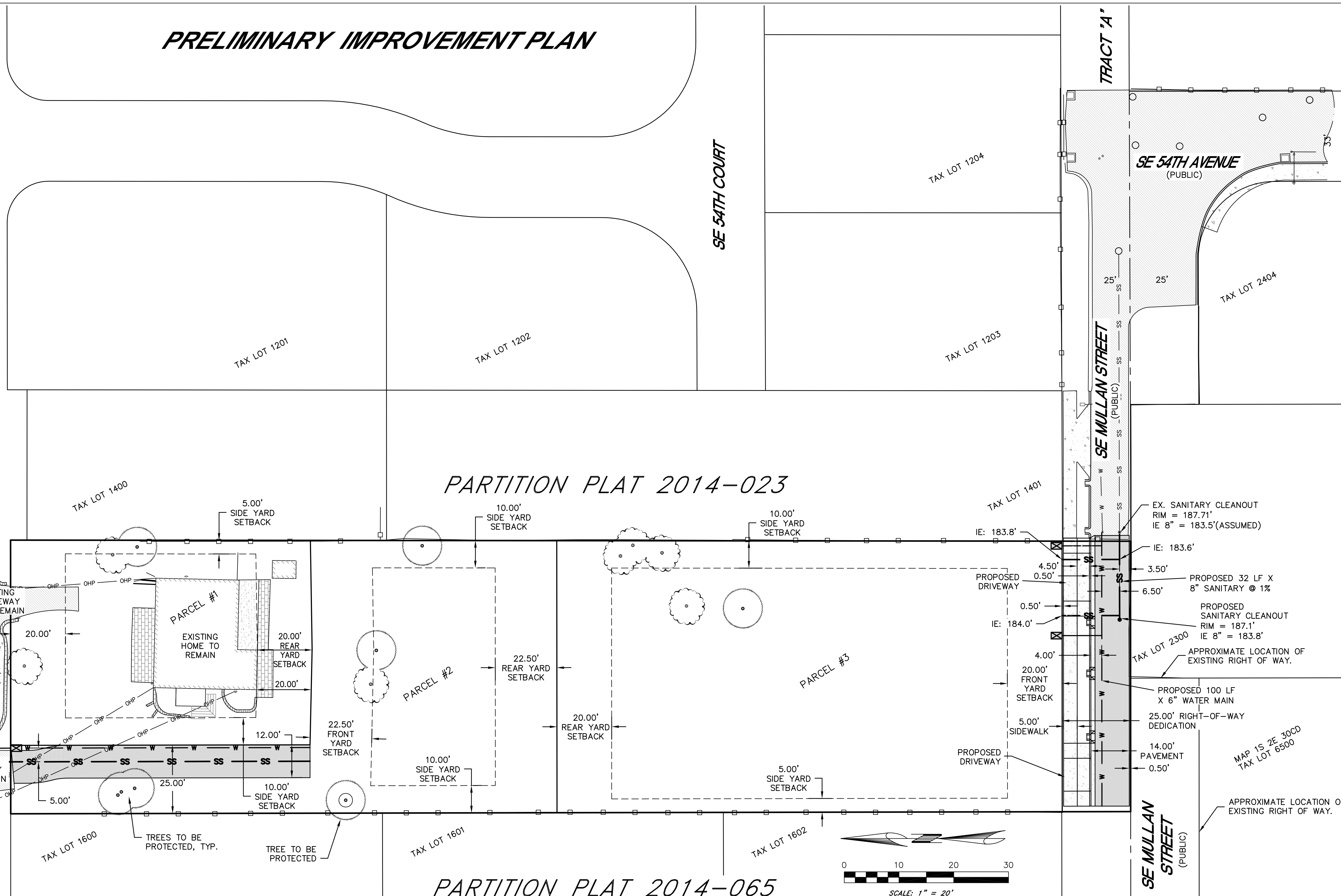

NOTES: THIS IS NOT A BOUNDARY SURVEY. ALL BOUNDARY LINE INFORMATION SHOWN ON THIS MAP WAS RETRIEVED FROM CHASE, JONES AND ASSOCIATES, INC. AND CURRENT TAX MAP INFORMATION.

SIDE YARD SETBACKS SHOWN ON THIS MAP MAY VARY BASED ON FINAL HOME DESIGN.

**REQUIRED R7-SETBACKS**  
FRONT YARD: 20'  
SIDE YARD: ONE SIDE YARD 5', THE OTHER SIDE YARD SHALL BE 10'  
STREET SIDE YARD: 20'  
REAR YARD: 20'

**REQUIRED FLAG LOT SETBACKS:**  
FRONT YARD: 30'  
REAR YARD: 30'  
SIDE YARD: 10'

**PROPOSED FLAG LOT SETBACKS:**  
FRONT YARD: 22.5' (25% VARIANCE REQUEST)  
REAR YARD: 22.5' (25% VARIANCE REQUEST)

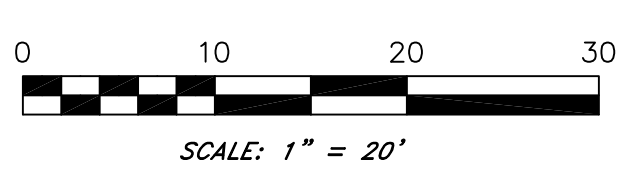

MAP 15 2E 30CD  
TAX LOT 6500

APPROXIMATE LOCATION OF EXISTING RIGHT OF WAY.