

Code Amendments – Clean Version

TITLE 19 ZONING

CHAPTER 19.200 DEFINITIONS AND MEASUREMENTS

19.201 DEFINITIONS

As used in this title:

“Carport” means a stationary structure consisting of a roof, its supports, and not more than 1 wall (or storage cabinets substituting for a wall) used to shelter motor vehicles, recreational vehicles, or boats.

CHAPTER 19.300 BASE ZONES

19.303 COMMERCIAL MIXED-USE ZONES

19.303.3 Development Standards

These development standards are intended to ensure that new development in the commercial mixed-use zones is appropriate for a mixed-use district in terms of building mass and scale, how the building addresses the street, and where buildings are located on a site.

Table 19.303.3 summarizes some of the development standards that apply in the commercial mixed-use zones. Development standards are presented in detail in Subsection 19.303.4.

Table 19.303.3 Commercial Mixed Use Zones—Summary of Development Standards			
Standard	GMU	NMU	Standards/ Additional Provisions
A. Lot Standards			
1. Minimum lot size (sq ft)	1,500	1,500	
2. Minimum street frontage (ft)	25	25	
B. Development Standards			
1. Minimum floor area ratio	0.5:1	0.5:1	Subsection 19.303.4.A Floor Area Ratio
2. Building height (ft)			Subsection 19.303.4.B Building Height
a. Base maximum	45	45	Section 19.510 Green Building Standards Subsection 19.911.7 Building Height Variance in the General Mixed Use Zone
b. Maximum with height bonus	57–69	Height bonus not available	

3. Street setbacks (ft) a. Minimum street setback b. Maximum street setback c. Side and rear setbacks	0–15 ¹ 10–20 ² None	None 10 None	Subsection 19.303.4.C Street Setbacks Section 19.501.2 Yard Exceptions
4. Frontage occupancy	50%	None	Subsection 19.303.4.D Frontage Occupancy Requirements Figure 19.303.4.D Frontage Occupancy Requirements
5. Maximum lot coverage	85%	85%	
6. Minimum vegetation	15%	15%	Subsection 19.504.6 Minimum Vegetation
7. Primary building entrances	Yes	Yes	Subsection 19.303.4.E Primary Building Entrances
8. Off-street parking standards	Yes	Yes	Chapter 19.600 Off-Street Parking and Loading
9. Transit street	Yes	Yes	Subsection 19.505.8 Building Orientation to Transit
10. Transition measures	Yes	Yes	Subsection 19.504.5 Transition Area Measures
C. Other Standards			
1. Residential density requirements (dwelling units per acre) a. Stand-alone residential (1) Minimum (2) Maximum b. Mixed-use buildings	25 50 None	11.6 14.5 None	Subsection 19.202.4 Density Calculations Subsection 19.303.4.F Residential Density Subsection 19.501.4 Density Exceptions
2. Signs	Yes	Yes	Subsection 14.16.040 Commercial Zone

1. Residential edge treatments apply to properties as shown in Figure 19.303.5.

2. Commercial edge treatments apply to properties as shown in Figure 19.303.4.C.2.b.

19.303.6 Additional Provisions

Depending upon the type of use and development proposed, the following sections of the Milwaukie Municipal Code may apply. These sections are referenced for convenience, and do not limit or determine the applicability of other sections within the Milwaukie Municipal Code.

B. Section 19.600 Off-Street Parking and Loading

Contains standards for vehicle and bicycle parking, including maximum number of spaces and design standards for parking and loading areas where provided.

19.304 DOWNTOWN ZONES

MMC 19.304.4 Development Standards

Table 19.304.4 CONTINUED Downtown Zones—Summary of Development Standards			
Standard	DMU	OS	Standards/ Additional Provisions
B. Development Standards CONTINUED			
3. Street setbacks (ft) a. Minimum street setback b. Side and rear setbacks	0 None	0 None	Subsection 19.304.5.C Street Setbacks Subsection 19.501.2 Yard Exceptions
4. Off-street parking standards	Yes, where applicable	Yes, where applicable	Subsection 19.304.5.D Off-Street Parking Chapter 19.600 Off-Street Parking and Loading

MMC 19.304.5 Detailed Development Standards

The following detailed development standards describe additional allowances, restrictions, and exemptions related to the development standards of Table 19.304.4.

D. Off-Street Parking

1. Intent

The desired character for the DMU Zone, particularly along Main Street, is defined by a continuous façade of buildings close to the street, with adjacent on-street parking.

2. Standards

- a. If off-street parking is provided for residential or nonresidential uses, the parking maximums in Table 19.605.1 will apply. All other applicable standards of Chapter 19.600 will also apply.
- b. Off-street surface parking lots (including curb cuts) must not be located within 50 ft of the Main Street right-of-way. Off-street surface parking lots approved prior to October 31, 2015, the effective date of Ordinance #2106, are exempt from this prohibition. This exemption applies only to the property owner on file with the Clackamas County Assessor as of October 31, 2015, the effective date of Ordinance #2106, and is dissolved upon transfer of ownership.

The Planning Commission may permit off-street parking lots and curb cuts within 50 ft of the Main Street right-of-way only upon finding, through Type III Variance review pursuant to Section 19.911, that:

- (1) The overall project meets the intent of providing a continuous façade of buildings close to Main Street.
 - (2) The off-street parking area or curb cut is visually screened from view from Main Street.
 - (3) The community need for the off-street parking area or curb cut within 50 ft of Main Street outweighs the need to provide a continuous façade of buildings in that area.
- c. Off-street parking must not be located between a building and the street-facing lot line.

**Figure 19.304.5.D.2
Off-Street Parking Standards**

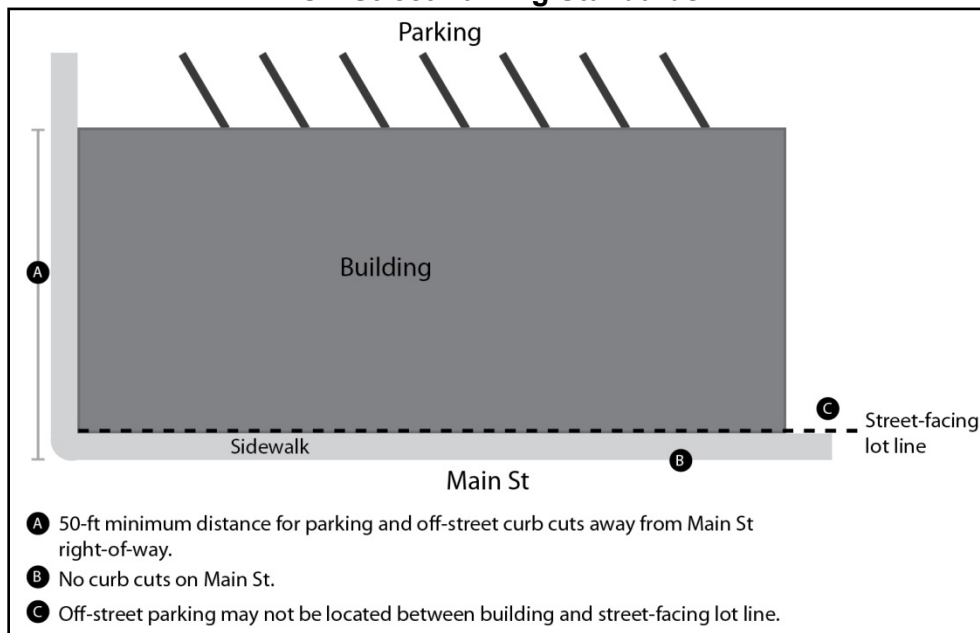

19.310 BUSINESS INDUSTRIAL ZONE BI

19.310.5 Conditional Uses

- A. Conditional uses may be established in a business industrial district subject to review and action on the specific proposal, pursuant to Section 19.905 Conditional Uses. Approval shall not be granted unless the proposal satisfies the criteria in Section 19.905; and, in addition, the proposed use:
1. Will have minimal adverse impact on the appropriate development of uses permitted outright on abutting properties and the surrounding area considering location, size, design, and operating characteristics of the use;
 2. Is compatible with the character and scale of uses allowed within the district and on a site no larger than necessary for the use and operational requirements of the use;

3. Will provide vehicular and pedestrian access, circulation, and loading areas which are compatible with uses on the same site or adjacent sites; and
4. Is a needed service/product in the district, considering the mix of potential clientele and the need to maintain high-quality development in a highly visible area.

19.310.6 Standards

In the BI district, the following standards shall apply to all uses:

H. Landscaping

15% of the site must be landscaped, except for sites adjacent to Hwy. 224, which shall provide landscaping to 20% of the site. This should consist of a variety of lawn, trees, shrubbery, and ground cover. Street trees must be provided along street frontages and within off-street parking lots to help delineate entrances, provide shade, and permeable areas for stormwater runoff. A bond or financial guarantee for landscape completion shall be required.

19.312 NORTH MILWAUKIE INNOVATION AREA

19.312.5 Development Standards

These development standards are intended to ensure that new development is appropriate in terms of building mass and scale, how the building addresses the street, and where buildings are located on a site.

Table 19.312.5 summarizes some of the development standards that apply in the NMIA. Development standards are presented in detail in Subsection 19.312.6.

Table 19.312.5			
North Milwaukie Innovation Area — Summary of Development Standards			
Standard	NME	MUTSA	Standards/Additional Provisions
A. Lot Standards			
1. Minimum lot size (sq ft)	None	None	
2. Minimum street frontage (ft)	None	None	
B. Development Standards			
1. Floor area ratio (min/max)	0.5:1/3:1	0.5:1/3:1	
2. Building height (ft)			
a. Minimum	25	25	Subsection 19.312.6.A Building height bonus Subsection 19.510 Green Building Standards
b. Maximum (Height bonus available)	45-90	45-90	
3. Setbacks (ft)			Subsection 19.501.2 Yard Exceptions
a. Minimum front yard setback	None	None	
b. Maximum front yard setback	10-30 ¹	10-30 ¹	
c. Side and rear setbacks	None ²	None ²	
4. Maximum lot coverage	85%	85%	
5. Minimum landscaping	15%	15%	Subsection 19.312.6.G Landscaping
6. Flexible ground-floor space	Yes, where applicable	Yes, where applicable	Subsection 19.312.7.A.6 Flexible ground-floor space
7. Off-street parking standards	Yes	Yes	Subsection 19.312.6.C Loading and Unloading Areas Subsection 19.312.7.C Parking, Loading and Unloading Areas Chapter 19.600 Off-Street Parking and Loading
8. Frontage occupancy	50%	50%	Subsection 19.312.7.A.7 Frontage occupancy

CHAPTER 19.500 SUPPLEMENTARY DEVELOPMENT REGULATIONS

19.504 SITE DESIGN STANDARDS

19.504.7 On-Site Walkways and Circulation

A. Requirement

All development subject to Chapter 19.700 (excluding single detached, middle housing, and multi-unit residential development) shall provide a system of walkways that encourages safe and convenient pedestrian movement within and through the development site. Redevelopment projects that involve remodeling or changes in use must be brought closer into conformance with this requirement to the greatest extent practicable. On-site walkways shall link the site with the public street sidewalk system, where sidewalks exist, or to the edge of the paved public street, where sidewalks do not exist. Walkways are required between parts of a site where the public is invited to walk. Walkways are not required between buildings or portions of a site that are not intended or likely to be used by pedestrians, such as truck loading docks and warehouses.

19.505 BUILDING DESIGN STANDARDS

19.505.3 Multi-Unit Housing

D. Design Guidelines and Standards

Applicable guidelines and standards for multi-unit and residential care facilities are located in Table 19.505.3.D. These standards should not be interpreted as requiring a specific architectural style.

Table 19.505.3.D		
Multi-Unit Design Guidelines and Standards		
Design Element	Design Guideline (Discretionary Process)	Design Standard (Objective Process)
3. Pedestrian Circulation	Site design should promote safe, direct, and usable pedestrian facilities and connections throughout the development. Ground-floor units should provide a clear transition from the public realm to the private dwellings.	The on-site pedestrian circulation system shall include the following: <ul style="list-style-type: none"> a. Continuous connections between the primary buildings, streets abutting the site, ground level entrances, common buildings, common open space, vehicle and bicycle parking areas, and transit facilities abutting the site. b. At least 1 pedestrian connection to an abutting street frontage for each 200 linear ft of street frontage. c. Pedestrian walkways shall be separated from vehicle parking and maneuvering areas by physical barriers such as planter strips, raised curbs, or bollards. d. Walkways shall be constructed with a hard surface material, shall be permeable for stormwater, and shall be no less than 5 ft wide. If adjacent to a parking area where vehicles will overhang the walkway, a 7-ft-wide walkway shall be provided. The walkways shall be separated from parking areas and internal driveways using curbing, landscaping, or distinctive paving materials.

Table 19.505.3.D CONTINUED		
Multi-Unit Design Guidelines and Standards		
Design Element	Design Guideline (Discretionary Process)	Design Standard (Objective Process)
		e. On-site walkways shall be lighted to an average 5/10-footcandle level. Stairs or ramps shall be provided where necessary to provide a direct route.
4. Vehicle and Bicycle Parking	Vehicle parking should be integrated into the site in a manner that does not detract from the design of the building, the street frontage, or the site. Bicycle parking should be secure, sheltered, and conveniently located.	Parking for the development shall comply with the following: <ul style="list-style-type: none"> a. On-site surface parking areas, garages, and vehicle maneuvering areas shall not be located directly between the façade of a primary building(s) and an abutting street right-of-way. b. Parking located to the side of a dwelling structure shall be limited to 50% of the linear frontage of that side. Drive aisles without adjacent parking spaces do not count as parking areas for purposes of this standard. c. All garages that are part of the same structure that contains dwelling units shall be located at least 4 ft behind the front building façade. d. See Section 19.609 for bicycle parking requirements.

19.505.4 Cottage Cluster Housing

C. Development Standards

The standards listed below in Table 19.505.4.C.1 are the applicable development and design standards for cottage cluster housing. Additional design standards are provided in Subsection 19.505.1.

Table 19.505.4.C.1		
Cottage Cluster Development Standards		
Standards	R-MD	R-HD, GMU, NMU
A. Home Types		
1. Building types allowed, minimum and maximum number per cluster	Detached cottages 3 minimum 12 maximum dwelling units	Detached and Attached 3 minimum 12 maximum dwelling units
B. Home Size		
1. Max building footprint per home	900 sf	

2. Max average floor area per dwelling unit	1,400 sf	
C. Height		
1. Max height	25 ft or 2 stories, whichever is greater	
2. Max structure height between 5 & 10 ft of rear lot line	15 ft	
3. Max height to eaves facing common green	1.618 times the narrowest average width between two closest buildings	
D. Setbacks, Separations, and Encroachments		
1. Separation between structures (minimum)	6 ft	
2. Side and rear site setbacks	5 ft	
3. Front site setback (minimum)	10 ft	
Table 19.505.4.C.1 CONTINUED Cottage Cluster Development Standards		
Standards	R-MD	R-HD, GMU, NMU
4. Front site setback (maximum)	20 ft	
5. Separation between clusters (minimum)	10 ft	
E. Impervious Area, Vegetated Area		
1. Impervious area (maximum)	60%	65%
2. Vegetated site area (minimum)	35%	35%
F. Community and Common Space		
1. Community building footprint (maximum) ¹	1,000 sf	1,000 sf
2. Common Space	19.505.4.E.2	19.505.4.E.2
G. Parking (see also 19.505.4.E.4)		
1. Automobile parking spaces per dwelling unit (maximum)	See MMC Section 19.605	
2. Bicycle Parking spaces per dwelling unit (minimum)	See MMC Section 19.609	

E. Site Design and Other Standards

4. Off-Street Parking

- a. When off-street parking is provided, parking spaces must be located together with parking spaces for other cottages in a common area, and not located on the same lot as an individual cottage unit.
- b. A cottage cluster parking area must be set back from the street. The distance of the setback is dependent on the orientation of the structure or lot. If the axis of the

longest dimension of the parking area has an angle of 45 degrees or more to the lot line, the narrow dimension may be within 5 ft of the street. If the angle is less than 45 degrees, the parking area must be at least 20 ft from the street.

- c. If there are more than 8 units in a cottage cluster and off-street parking is provided, there must be at least 2 separate parking areas with a minimum of 4 parking spaces in each area. A drive aisle connecting the 2 areas is permitted if a separate driveway access for each area is not permitted per Chapter 12.16 Access Management.
- d. Parking spaces may be located within a garage or a carport. Garages or carports in a cottage cluster may not contain more than 4 parking spaces, must be at least 10 ft from any cottage dwelling; and must match the materials, trim, and roof pitch of the cottages. The interior height of a garage or carport shall not exceed 8 ft high, unless a modification is requested for cases that would use space saving parking technology (e.g., interior car stacking) that might require additional interior height. This modification would be requested per Section 19.911 Variances.
- e. Parking spaces that are not in a garage or carport must be screened from common open space, public streets, and adjacent residential uses by landscaping and/or screen, such as a fence. Chain-link fencing with slats is not allowed as a screen.
- f. Off-street parking may be arranged in clusters, subject to the following standards:
 - (1) Cottage cluster projects with fewer than 16 cottages are permitted parking clusters of not more than 5 contiguous spaces.
 - (2) Cottage cluster projects with 16 cottages or more are permitted parking clusters of not more than 8 contiguous spaces.
 - (3) Parking clusters must be separated from all other areas by at least 4 ft of landscaping.
 - (4) Clustered parking areas may be covered.
- g. Off-street parking spaces and vehicle maneuvering areas must not be located:
 - (1) Within 20 ft of any street property line, except alley property lines;
 - (2) Between a street property line and the front façade of cottages located closest to the street property line. This standard does not apply to alleys;
 - (3) Off-street parking spaces must not be located within 10 ft of any other property line, except alley property lines. Driveways and drive aisles are permitted within 10 ft of other property lines.
- h. Landscaping, fencing, or walls at least 3 ft tall must separate clustered parking areas and parking structures from common courtyards and public streets.
- i. Garages and carports (whether shared or individual) must not abut common courtyards.
- j. Individual detached garages must not exceed 400 sq ft in floor area and are exempted from the calculation of maximum building footprint for cottages.
- k. Garage doors for attached and detached individual garages must not exceed 20 ft in width.

CHAPTER 19.600 Off-Street Parking and Loading

19.601 PURPOSE

Chapter 19.600 regulates off-street parking and loading areas on private property outside the public right-of-way. The purpose of Chapter 19.600 is to: support efficient streets; avoid unnecessary conflicts between vehicles, bicycles, and pedestrians; encourage bicycling, transit, and carpooling; minimize parking impacts to adjacent properties; improve the appearance of parking areas; and minimize environmental impacts of parking areas.

Regulations governing the provision of on-street parking within the right-of-way are contained in Chapter 19.700. The management of on-street parking is governed by Chapter 10.20. Chapter 19.600 does not enforce compliance with the Americans with Disabilities Act (ADA). ADA compliance on private property is reviewed and enforced by the Building Official. (Ord. 2218 § 2 (Exh. B), 2022; Ord. 2106 § 2 (Exh. F), 2015; Ord. 2025 § 2, 2011)

19.602 APPLICABILITY

19.602.1 General Applicability

The regulations of Chapter 19.600 apply to all off-street parking areas and off-street loading areas. Activity that is not described by Subsections 19.602.3 or 4 is exempt from compliance with the provisions of Chapter 19.600. Changes to nonconforming off-street parking and loading are addressed through Chapter 19.600 and not through the provisions of Chapter 19.800.

19.602.3 Applicability for Development and Change in Use Activity

The provisions of Chapter 19.600 apply to development and changes of use as described in Subsection 19.602.3.

A. Development of a vacant site shall have off-street parking and off-street loading areas that conform to the requirements of Chapter 19.600. Development of a site that results in an increase of 100% or more of the existing floor area and/or structure footprint on a site shall also conform to the requirements of Chapter 19.600. The construction of new off-street parking spaces may be subject to the electric vehicle charging requirements of Subsection 19.605.5. The floor area and/or footprint of structures demolished prior to development or redevelopment on the site shall not be considered when calculating the increase in floor area and/or structural footprints.

B. Existing off-street parking and loading areas shall be brought closer into conformance with the standards of Chapter 19.600, per Subsection 19.602.5, when the following types of development or change in use occur:

1. Development that results in an increase of less than 100% of the existing floor area and/or structure footprint.
2. Changes of use, as defined in Section 19.201.
3. For existing parking lots 1/2-acre or greater in size, Subsection 19.606.4 is applicable when 50% or more of the existing asphalt or pavement is excavated. Required improvements for parking lots subject to the provisions of Subsection 19.606.4 are not limited by Subsection 19.602.5.

19.602.4 Applicability Not Associated With Development or Change in Use

- A. Any parking or loading area developed to serve an existing use(s) that is not associated with development activity or a change in use described in Subsection 19.602.3 shall conform to the requirements of Sections 19.604 and 19.606-19.611, as well as to the electric vehicle (EV) charging requirements of Subsection 19.605.4 as applicable. The total number of spaces in the existing parking area and new parking area shall not exceed the maximum allowed quantity of parking as established in Section 19.605.

19.602.5 Improvements to Existing Off-Street Parking and Loading Areas

- A. Purpose

The purpose of Subsection 19.602.5 is to improve nonconforming off-street parking and loading areas as redevelopment occurs. These improvements should occur in conjunction with a development or change in use.

- B. Limitations on Required Improvements

The cost of materials for any required improvements shall not exceed 10% of the development permit value of the associated development, redevelopment, and/or tenant improvements associated with a change in use. The cost of capital equipment such as manufacturing or operational equipment is exempt from the building permit value for purposes of this regulation. This exemption does not include building infrastructure such as electrical, plumbing, heating, venting, or air conditioning equipment.

- C. Areas of Required Improvement

The Planning Director will evaluate the applicant’s parking plan and use the prioritized list below when determining what improvements will be required.

1. Paving and striping of parking areas, per Subsection 19.606.3.A.
2. Minimum required bicycle parking spaces, per Section 19.609.
3. Landscaping of existing buffers, islands, and medians, per Subsection 19.606.2.D.
4. New perimeter landscape buffers, islands, and medians, as applicable, per Subsection 19.606.2.
5. Other applicable standards within Chapter 19.600, as determined by the Planning Manager.

19.603 REVIEW PROCESS AND SUBMITTAL REQUIREMENTS

19.603.1 Review Process

The Planning Manager shall apply the provisions of Chapter 19.600 in reviewing all land use and development permit applications, except when an application is subject to a quasi-judicial land use review or appeal, in which case the body reviewing the application or appeal has the authority to implement and interpret the provisions of Chapter 19.600.

19.603.2 Submittal Requirements

Except for single detached dwellings or development situations where no off-street parking is being provided, a development or change in use subject to Chapter 19.600 as per Section 19.602 shall submit a parking plan, drawn to scale. The parking plan shall show that all applicable standards are met, and shall include but not be limited to the items listed below, unless waived by the Planning Manager.

- A. Delineation of individual spaces and wheel stops.
- B. Drive aisles necessary to serve spaces.
- C. Accessways, including driveways and driveway approaches, to streets, alleys, and properties to be served.
- D. Pedestrian pathways and circulation.
- E. Bicycle parking areas and rack specifications.
- F. Fencing.
- G. Abutting land uses.
- H. Grading, drainage, surfacing, and subgrading details.
- I. Location and design of lighting fixtures and levels of illumination.
- J. Delineation of existing and proposed structures.
- K. Parking and loading area signage.
- L. Landscaping, including the following information.
 - 1. The location and area of existing and proposed trees, vegetation, and plant materials, including details about the number, size, and species of such items.
 - 2. Notation of the trees, plants, and vegetation to be removed, and protection measures for existing trees and plants to be preserved.

(Ord. 2025 § 2, 2011)

19.604 GENERAL PARKING STANDARDS

19.604.1 Parking Provided with Development Activity

All off-street parking areas shall be provided in conformance with the standards of Chapter 19.600 prior to issuance of a certificate of occupancy, or final development permit approval, or as otherwise specified in any applicable land use decision.

19.604.2 Parking Area Location

Accessory parking shall be located in one or more of the following areas:

- A. On the same site as the primary use for which the parking is accessory.
- B. On a site owned by the same entity as the site containing the primary use that meets the standards of Subsection 19.605.4.B.2. Accessory parking that is located in this manner shall not be considered a parking facility for purposes of the base zones in Chapter 19.300.
- C. Where parking is approved in conformance with Subsection 19.605.2.
- D. On a site serving a separate primary use when a shared parking agreement has been procured.

19.604.3 Converting Off-Street Parking Areas

When converting an automobile parking area to another use, access for emergency vehicles must be maintained, and adequate parking for truck loading should be considered.

19.605 VEHICLE PARKING QUANTITY REQUIREMENTS

The purpose of Section 19.605 is to ensure that development does not provide excessive vehicle parking based on their estimated parking demand. Subsection 19.605.1 establishes parking ratios for common land uses, and Subsection 19.605.3 allows certain exemptions and reductions to these ratios based on location or on-site amenities. Subsection 19.605.4 details requirements for installing electric vehicle (EV) charging infrastructure in new multi-unit, mixed-use, commercial, and industrial developments. Modifications to the established parking ratios and determinations of parking requirements for unique land uses are allowed with discretionary review per Subsection 19.605.2.

19.605.1 Parking Maximums

- A. When off-street parking is provided with development, the number of spaces shall not be more than the maximum number of parking spaces as listed in Table 19.605.1. Modifications to the standards in Table 19.605.1 may be made as per Section 19.605. Where multiple ratios are listed, the Planning Manager shall determine which ratio to apply to the proposed development or use.
- B. When a specific use has not been proposed or identified at the time of permit review, the Planning Manager may elect to assign a use category from Table 19.605.1 to determine the maximum allowed parking. Future tenants or property owners are responsible for compliance with Chapter 19.600 per the applicability provisions of Section 19.602.
- C. If a proposed use is not listed in Table 19.605.1, the Planning Manager has the discretion to apply the maximum requirements of a similar use listed in the table upon finding that the listed use and unlisted use have similar parking demands. If a similar use is not listed, the maximum allowance will be determined per Subsection 19.605.2.
- D. Where the calculation of maximum parking spaces does not result in a whole number, the result shall be rounded to the nearest whole number.
- E. Parking spaces for disabled persons, and other improvements related to parking, loading, and maneuvering for disabled persons, shall conform to the Americans with Disabilities Act and shall be subject to review and approval by the Building Official. Spaces reserved for disabled persons are included in the maximum allowed number of off-street parking spaces.
- F. Uses that have legally established parking areas that exceed the maximum number of spaces allowed by Section 19.605 prior to June 17, 2010, the effective date of Ordinance #2015, shall be considered nonconforming with respect to the quantity requirements. Such uses shall not be considered parking facilities as defined in Section 19.201.

Table 19.605.1 Maximum Off-Street Parking Standards	
Use	Maximum Allowed
A. Residential Uses	
1. Single detached dwellings, including manufactured homes.	No maximum.
2. Multi-Unit Dwellings	2 spaces per dwelling unit.

3. Middle Housing ¹ a. Duplexes b. Triplexes c. Quadplexes d. Townhouses ² e. Cottage Clusters	1 space per dwelling unit 1 space per dwelling unit 1 space per dwelling unit 1 space per dwelling unit 1 space per dwelling unit
4. Residential homes and similar facilities allowed by right in residential zones.	Minimum required parking <u>1 space per employee on the largest shift</u> plus 1 space per bedroom.
5. Accessory dwelling units (ADU).	No maximum.

Table 19.605.1 CONTINUED	
Maximum Off-Street Parking Standards	
Use	Maximum Allowed
B. Community Service and Other Public Uses	
1. Religious institutions.	1 space per 2 seats.
2. Day-care center (“family day-care” as defined in Section 19.201 has no parking requirements).	3.5 spaces per 1,000 sq ft of floor area.
3. School—elementary or junior high.	2 spaces per classroom.
4. School—senior high.	0.33 spaces per student, plus 1 space per staff.
5. Meeting room, club, lodge, or association.	16.66 spaces per 1,000 sq ft of floor area, or 1 space per 3 seats if seats are permanently installed.
6. Library, museum, art gallery.	1.2 spaces per 1,000 sq ft of floor area.
7. Nursing, convalescent, and extended-care facilities.	1 space per 3 beds.
C. Lodging Places	
1. Motel, hotel, boarding house.	1.5 spaces per lodging unit.
2. Bed and breakfast establishments.	1.5 spaces per lodging unit, plus 2 spaces for the permanent residence.
D. Commercial Uses—Recreational	
1. Indoor recreation, such as a health club, gym, bowling alley, arcade, etc.	5.5 spaces per 1,000 sq ft of floor area.
2. Theater, auditorium, or stadium.	1 space per 3 seats.
E. Commercial Uses—Retail Goods	

1. Eating and drinking establishments.	15 spaces per 1,000 sq ft of floor area.
2. General retail—grocery stores, convenience stores, specialty retail and shops.	5 spaces per 1,000 sq ft of floor area.
3. Bulk retail—furniture and home furnishings, appliances, vehicles, building materials, and similar large items.	3 spaces per 1,000 sq ft of floor area.
4. Gas stations.	1.25 spaces per 4 pumps.
F. Commercial Uses—Services	
1. General office, including banks.	3.4 spaces per 1,000 sq ft of floor area.
2. Medical/dental office (non-hospital), veterinary clinic.	4.9 spaces per 1,000 sq ft of floor area.
Table 19.605.1 CONTINUED Maximum Off-Street Parking Standards	
Use	Maximum Allowed
F. Commercial Uses—Services CONTINUED	
3. Personal services, such as a barbershop, beauty parlor, etc.	5.4 spaces per 1,000 sq ft of floor area.
4. Commercial services, such as dry cleaners and repair shops (does not include vehicle repair).	5.1 spaces per 1,000 sq ft of floor area.
5. Vehicle repair.	2.5 spaces per 1,000 sq ft of floor area.
6. Quick vehicle repair and servicing, such as oil change and tire shops.	3 spaces per service bay.
7. Mortuary/funeral home.	1 space per 3 chapel or parlor seats.
8. Car wash.	2 spaces per wash bay for self-service washes, or 2 spaces per 1,000 sq ft of floor area for full-service washes.
G. Industrial Uses	
1. Manufacturing.	2 spaces per 1,000 sq ft of floor area.
2. Storage, warehouse, wholesale establishment less than 150,000 sq ft.	1 space per 1,000 sq ft of floor area.
3. Storage, warehouse, wholesale establishment 150,000 sq ft or greater.	0.4 spaces per 1,000 sq ft of floor area.

4. Mini-warehouse; self-service storage.	1 space per 20 storage units, plus 1 space per employee of the largest shift.
--	---

19.605.2 Maximum Quantity Modifications and Parking Determinations

Subsection 19.605.2 allows for the modification of maximum parking ratios from Table 19.605.1 as well as the determination of maximum parking requirements. Parking determinations shall be made when the proposed use is not listed in Table 19.605.1 and for developments with parking demands that are higher than the maximum allowed.

A. Applicability

The procedures of Subsection 19.605.2 shall apply in the following situations:

1. If the proposed use is not listed in Table 19.605.1 and the maximum allowed quantity for a similar listed use cannot be applied.
2. If the applicant seeks a modification from the maximum allowed quantities as calculated per Table 19.605.1.

B. Application

Determination of parking ratios in situations listed above shall be reviewed as a Type II land use decision, per Section 19.1005 Type II Review. The application for a determination must include the following:

1. Describe the proposed uses of the site, including information about the size and types of the uses on site, and information about site users (employees, customers, residents, etc.).
2. Identify factors specific to the proposed use and/or site, such as the proximity of transit, parking demand management programs, availability of shared parking, and/or special characteristics of the customer, client, employee or resident population that affect parking demand.
3. Provide data and analysis specified in Subsection 19.605.2.B.3 to support the determination request. The Planning Manager may waive requirements of Subsection 19.605.2.B.3 if the information is not readily available or relevant, so long as sufficient documentation is provided to support the determination request.
 - a. Analyze parking demand information from professional literature that is pertinent to the proposed development. Such information may include data or literature from the Institute of Transportation Engineers, American Planning Association, Urban Land Institute, or other similar organizations.
 - b. Review parking standards for the proposed use or similar uses found in parking regulations from other jurisdictions.
 - c. Present parking quantity and parking use data from existing developments that are similar to the proposed development. The information about the existing development and its parking demand shall include enough detail to evaluate similarities and differences between the existing development and the proposed development.
 - d. For middle housing, provide occupancy and use data quantifying conditions of the on-street parking system within one block of the middle housing development.

4. Propose a maximum parking ratio. For phased projects, and for projects where the tenant mix is unknown or subject to change, the applicant may propose a maximum for each development phase.
5. Address the approval criteria in Subsection 19.605.2.C.

C. Approval Criteria

The Planning Manager shall consider the following criteria in deciding whether to approve the determination or modification. The Planning Manager, based on the applicant's materials and other data the Planning Manager deems relevant, shall set the maximum parking allowed. Conditions of approval may be placed on the decision to ensure compliance with the parking determination.

1. All modifications and determinations must demonstrate that the proposed parking quantities are reasonable based on existing parking demand for similar use in other locations; parking quantity allowances for the use in other jurisdictions; and professional literature about the parking demands of the proposed use.
2. In addition to the criteria in Subsection 19.605.2.C.1, requests for modifications to increase the amount of maximum allowed parking shall meet the following criteria:
 - a. The proposed development has unique or unusual characteristics that create a higher-than-typical parking demand.
 - b. The parking demand cannot be accommodated by shared or joint parking arrangements or by increasing the supply of spaces that are exempt from the maximum amount of parking allowed under Subsection 19.605.3.A.
 - c. The requested increase is the smallest increase needed based on the specific circumstances of the use and/or site.

19.605.3 Exemptions to Quantity Allowances

The following exemptions and by-right reductions cannot be used to further modify any parking modification or determination granted under Subsection 19.605.2.

A. Exemptions to Maximum Quantity Allowance

The following types of parking do not count toward the maximum amount of parking allowed on a site. This exemption applies only to the quantity requirements of Section 19.605 and not to the other requirements of Chapter 19.600. The City may impose conditions to ensure that parking spaces associated with these parking types are appropriately identified and used for the intended purpose.

1. Spaces for a parking facility.
2. Spaces for a transit facility or park and ride facility.
3. Storage or display areas for vehicle sales.
4. Employee carpool parking, when spaces are dedicated or reserved for that use.
5. Fleet parking.
6. Truck loading areas.

19.605.4 Electric Vehicle (EV) Charging Requirements

Required EV charging spaces. All new buildings that are commercial, industrial, multi-unit with 5 or more dwelling units, or mixed-use with 5 or more dwelling units and that provide new off-

street parking must include sufficient space for electrical service capacity to support at least a Level 2 EV charger at required EV charging spaces as outlined below. For terms not defined elsewhere in Title 19, see applicable sections of the state building code and/or OAR 918-460-0200.

A. Commercial and Industrial Buildings.

For new commercial and industrial buildings where new off-street parking spaces are constructed, choose one of the following:

1. At least 50% of the total number of newly constructed parking spaces must include electrical conduit adjacent to the spaces that will allow for the installation of at least a Level 2 EV charger; or
2. At least 20% of the total number of newly constructed parking spaces must include electrical conduit adjacent to the spaces that will allow for the installation of at least a Level 2 EV charger. At least 5% of newly constructed parking spaces must include an installed Level 2 or Level 3 EV charger. Parking spaces with installed chargers count toward the 20% minimum requirement.

B. Multi-Unit and Mixed-Use Residential Buildings.

For new multi-unit and mixed-use buildings with 5 or more dwelling units, where new off-street parking spaces are constructed, choose one of the following:

1. All (100%) of the newly constructed parking spaces must include electrical conduit adjacent to the spaces that will allow for the installation of at least a Level 2 EV charger; or
2. At least 40% of the total number of newly constructed parking spaces must include electrical conduit adjacent to the spaces that will allow for the installation of at least a Level 2 EV charger. At least 10% of newly constructed parking spaces must include an installed Level 2 or Level 3 EV charger. Parking spaces with installed chargers count toward the 40% minimum requirement.

C. Structured Parking Facilities.

For new structured parking facilities, where new off-street parking spaces are constructed, choose one of the following:

1. At least 50% of the total number of newly constructed parking spaces must include electrical conduit adjacent to the spaces that will allow for the installation of at least a Level 2 EV charger; or
2. At least 20% of the total number of newly constructed parking spaces must include electrical conduit adjacent to the spaces that will allow for the installation of at least a Level 2 EV charger. At least 5% of newly constructed parking spaces must include an installed Level 2 or Level 3 EV charger. Parking spaces with installed chargers count toward the 20% minimum requirement.

(Ord. 2236 § 2, 2023; Ord. 2224 § 2, 2022; Ord. 2221 § 2 (Exh. B), 2022; Ord. 2218 § 2 (Exh. B), 2022; Ord. 2186 § 2, 2019; Ord. 2161 § 2, 2018; Ord. 2112 § 2 (Exh. B), 2015; Ord. 2106 § 2 (Exh. F), 2015; Ord. 2051 § 2, 2012; Ord. 2025 § 2, 2011)

19.606 PARKING AREA DESIGN AND LANDSCAPING

The purpose of Section 19.606 is to ensure that off-street parking areas are safe, environmentally sound, aesthetically pleasing, and that they have efficient circulation. The requirements in Subsection 19.606.4 apply to all types of development where a new half-acre parking lot or larger is provided. All other standards apply to all types of development where parking is provided, except for middle housing, single detached dwellings, and adult foster/care homes.

19.606.1 Parking Space and Aisle Dimensions

- A. The dimensions for off-street parking spaces and abutting drive aisles, where provided, shall be no less than in Table 19.606.1. The minimum dimensions listed in Table 19.606.1 are illustrated in Figure 19.606.1.

Table 19.606.1 Minimum Parking Space And Aisle Dimensions					
Angle (A)	Width (B)	Curb Length (C)	1-Way Aisle Width (D)	2-Way Aisle Width (D)	Depth (E)
0° (Parallel)	8.5'	22'	12'	19'	8.5'
30°	9'	17'	12'	19'	16.5'
45°	9'	12'	13'	19'	18.5'
60°	9'	10'	17'	19'	19'
90°	9'	9'	22'	22'	18'

19.606.2 Landscaping

- C. Perimeter Landscaping

The perimeter landscaping of parking areas shall meet the following standards which are illustrated in Figure 19.606.2.C.

- 1. Dimensions

The minimum width of perimeter landscape areas are shown in Table 19.606.2.C.1. Where a curb provides the border for a perimeter landscape area, the dimension shall be measured from the inside of the curb(s). The Planning Manager may reduce the required minimum width of a perimeter landscaping area where existing development or site constraints make it infeasible to provide drive aisles, parking spaces, and the perimeter landscaping buffer width listed in Table 19.606.2.C.1.

19.606.3 Additional Design Standards

- A. Paving and Striping

Paving and striping are required for all maneuvering and standing areas. Off-street parking areas shall have a durable and dust-free hard surface, shall be maintained for all-weather use, and shall be striped to show delineation of parking spaces and directional markings for driveways and accessways. Permeable paving surfaces may be used to reduce surface water runoff and protect water quality.

D. Pedestrian Access and Circulation

Subsection 19.504.7 establishes standards that are applicable to an entire property for on-site walkways and circulation. The purpose of Subsection 19.606.3.D is to provide safe and convenient pedestrian access routes specifically through off-street parking areas.

Walkways required by Subsection 19.606.3.D are considered part of the on-site walkway and circulation system required by Subsection 19.504.7.

1. Pedestrian access shall be provided for off-street parking areas so that no parking space is further than 100 ft away, measured along vehicle drive aisles, from a building entrance, or a walkway that meets the standards of Subsection 19.606.3.D.2.
2. Walkways through off-street parking areas must be continuous, must lead to a building entrance, and meet the design standards of Subsection 19.504.7.E.

E. Internal Circulation

1. General Circulation

The Planning Manager has the authority to review the pedestrian, bicycle, and vehicular circulation of the site and impose conditions to ensure safe and efficient on-site circulation. Such conditions may include, but are not limited to, on-site signage, pavement markings, addition or modification of curbs, and modifying drive aisle dimensions.

2. Connections to Adjacent Parking Areas

Where feasible, parking areas shall be designed to connect with parking areas on adjacent sites to eliminate the use of the street for cross movements.

3. Drive-Through Uses and Queuing Areas

The following standards apply to uses with drive-through services and uses such as gas stations and quick vehicle service facilities where vehicles queue rather than park on the site. The Planning Manager has the authority to determine when the standards apply to a proposed use.

F. Lighting

Lighting is required for parking areas with more than 10 spaces. The Planning Manager may require lighting for parking areas of less than 10 spaces if the parking area would not be safe due to the lack of lighting. Lighting shall be designed to enhance safe access for vehicles and pedestrians on the site, and shall meet the following standards:

19.606.4 Surface Parking Areas Over One-Half Acre

A. Purpose and Applicability

To comply with OAR 660-012-0405 and to mitigate the negative impacts of large surface parking lots such as increased ambient temperatures, increased stormwater run-off, and diminished pedestrian connectivity, all newly proposed surface parking areas that are greater than one-half acre in size must comply with the standards in Subsection 19.606.4.

For existing parking lots 1/2-acre or greater in size, Subsection 19.606.4 is applicable when 50% or more of the existing asphalt or pavement is excavated. Required improvements for parking lots subject to the provisions of Subsection 19.606.4 are not limited by Subsection 19.602.5.

B. Measurement

Calculating the one-half acre threshold (21,780 sq ft) is based on the cumulative area measured around the perimeter of all new off-street parking spaces, vehicle maneuvering lanes, vehicle maneuvering areas, interior walkways, and interior landscaping areas. The calculation must include all new off-street parking areas, even when parking areas are scattered throughout a property or span multiple lots but serve a common use or uses.

C. General Requirements

Parking areas that are over one-half-acre in size must comply with all the standards below.

1. Development standards. These standards apply in addition to those in Subsections 19.606.3.D, 19.504.7, and Section 19.505. Where there is a conflict with those standards, the standards in Subsection 19.606.4 take precedence.
 - a. Walkway crossings at intersections with drive aisles and driveways must be provided. Crossing facilities must be demarcated by either a raised surface or by utilizing a separate surface material. Demarcation with the use of paint alone is not permitted.
 - b. Development must provide trees along driveways or a minimum of 30% tree canopy coverage over new parking areas. Developments providing 40% tree canopy under Subsection 19.606.4.C.2.b comply with this standard. Tree plantings must be consistent with the planting requirements in 19.606.4.D.
2. Climate Mitigation Actions. Developments not required to comply with OAR 330-135-0010 must provide one of the following:
 - a. Installation of solar panels with a generation capacity of at least 0.5 kilowatts per parking space on the property. Panels may be located anywhere on the property so long as their placement complies with other development standards in the Milwaukie Municipal Code.
 - b. Tree canopy covering at least 40 percent of the parking lot at maturity but no more than 15 years after planting, as measured per Subsection 19.606.4.D.

D. Tree Canopy Coverage Standards

The following standards apply when providing tree canopy coverage under Subsection 19.606.4.C.2.c.

1. Calculating Parking Lot Area to be Covered by Tree Canopy

When calculating the area required to be covered by a tree canopy for the purposes of this Subsection, the following rules must be followed:

- a. All surface areas on which a vehicle is designed to maneuver, such as drives, drive-through lanes, drive aisles, and parking stalls, must be included.
- b. Areas not used for passenger vehicles, such as loading areas, interior landscaped areas, interior walkways not designed to be used by a passenger vehicle, and areas that are permanently used for outdoor storage, can be excluded when calculating this area.

2. Calculating Tree Canopy Coverage

When calculating tree canopy coverage to comply with this Subsection, the following rules must be followed:

- a. The expected diameter of the tree crown at 15 years must be used to calculate tree canopy coverage, regardless of if the tree is mature at that time.

- b. The area under the expected canopy at 15 years that is either paved surface, including parking stalls and maneuvering areas, loading areas, walkways that are interior to the parking area, and interior and perimeter parking area landscaping will count towards meeting the required canopy coverage standard.
- c. The existing canopy of trees preserved on-site and providing coverage of the subject parking area can be counted towards the canopy coverage standard. The current diameter of a preserved tree's crown must be used to calculate tree canopy coverage. Or, if the tree was newly planted, the expected diameter of the tree crown area at 15 years can be used. Preserved trees used to meet this standard must be at least 2 in diameter at breast height if deciduous and at least 5 ft tall if coniferous.
- d. Trees located off-site, including those in the public right-of-way, do not count towards the canopy coverage standard.
- e. Newly planted trees that are isolated in disconnected individual planters are permitted but do not count towards the canopy coverage standard. The canopy of preserved trees that are isolated and at least 12 in diameter at breast height can count toward the canopy coverage standard.
- f. Canopy that covers structures does not count towards the canopy coverage standard unless covering a roofed but unenclosed structure that is used for protecting an automobile, bicycle, garbage/recycling area, or similar area from the elements.
- g. Canopy area of significant overlap does not count towards the canopy coverage standard. Significant overlap is defined as any overlap greater than 5 ft. The overlap measurement is the length of a line segment within the overlap area of a line between tree canopy trucks/centers. See Figure 19.606.4 for an example of this measurement.

Figure 19.606.4

Significant Canopy Overlap Measurement

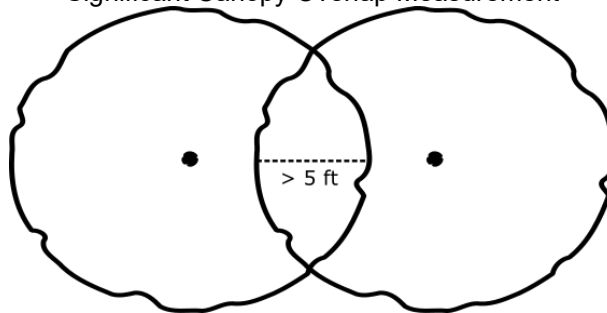

3. Tree Plan Submittal Requirements

The following must be submitted to demonstrate compliance with this standard at the time development permits are submitted or with any land-use application subject to this Subsection and Subsection 19.906.

- a. A tree plan must be submitted to the Urban Forester or designee per the submittal requirements in Subsection 16.32.042.H

- b. The tree plan shall be prepared by an ISA-certified arborist in coordination with local utility providers. The final tree plan must be reviewed and approved by the Urban Forester.

4. General Tree Planting and Maintenance Requirements

In providing trees under Subsection 19.606.4, plantings shall comply with the following standards.

- a. Trees must be planted in continuous trenches in perimeter and interior landscaping areas and spaced to maintain a continuous canopy 15 years after planting. Canopy spacing will be measured based on the expected diameter of the tree crown 15 years after planting. Sections of the canopy are considered continuous when there is no space greater than 3 ft between two or more projected crown areas. Gaps in the canopy are permitted to accommodate other features of the parking area, such as drive aisles.
- b. Applicants must submit a soil volume and protection plan for approval by the Urban Forester or designee as outlined in Subsection 16.32.042.G Soil Volume Standards.
- c. Applicants must submit a tree protection plan for approval by the Urban Forester or designee as outlined in Subsection 16.32.042.F Tree Protection Standards.
- d. Trees must be maintained to ensure their survival and long-term health. Inspection of tree health will occur at the time of site development and, to ensure tree survival, three to five years after planting.

19.607 OFF-STREET PARKING STANDARDS FOR RESIDENTIAL AREAS

19.607.1 Residential Driveways and Vehicle Parking Areas

Subsection 19.607.1 is intended to preserve residential neighborhood character by establishing off-street parking standards. The provisions of Subsection 19.607.1 apply to passenger vehicles and off-street parking areas for single detached dwellings, duplexes, triplexes, quadplexes, townhouses, cottage clusters, and residential homes in all zones, unless specifically stated otherwise.

A. Dimensions

Off-street parking space dimensions for required parking spaces are 9 ft wide x 18 ft deep.

B. Location

- 1. No portion of an off-street parking space is allowed within the following areas. These standards do not apply to off-street parking for cottage clusters, which are subject to the standards in Subsection 19.505.4.
 - a. Within an adjacent public street right-of-way or access easement.
 - b. Over a public sidewalk.

C. Parking Surface Materials

Parking of vehicles shall only be allowed on surfaces described in Subsection 19.607.1.C.

- 1. The following areas are required to have a durable and dust-free hard surface, and shall be maintained for all-weather use. The use of pervious concrete, pervious paving,

driveway strips, or an in-ground grid or lattice surface is encouraged to reduce stormwater runoff.

- a. All vehicle parking spaces and maneuvering areas located within a required front, street-side, or side yard. Areas for boat or RV parking outside of required front or street-side yards are exempt from this requirement and may be graveled.
 - b. All off-street parking and maneuvering areas for an adult foster/care home.
2. Maneuvering areas and parking areas that are outside of a required front or side yard are allowed to have a gravel surface.

D. Parking Area Limitations

Uncovered parking spaces and maneuvering areas for vehicles, and for recreational vehicles and pleasure craft as described in Subsection 19.607.2.B, have the following area limitations. See Figure 19.607.1.D. The pole portion of a flag lot is not included in these area limitations.

These standards do not apply to off-street parking for cottage clusters, which are subject to the standards in Subsection 19.505.4; nor to townhouses, which are subject to the standards in Subsection 19.505.5.

- 1. Uncovered parking spaces and maneuvering areas cannot exceed 50% of the front yard area.
- 2. Uncovered parking spaces and maneuvering areas cannot exceed 30% of the required street side yard area.
- 3. No more than 3 residential parking spaces are allowed within the required front yard. A residential parking space in the required front yard is any 9- x 18-ft rectangle that is entirely within the required front yard that does not overlap with another 9- x 18-ft rectangle within the required front yard. Quadplexes are permitted a fourth parking space within the required front yard.

Figure 19.607.1.D

Front and Street Side Yard Parking Area Limits

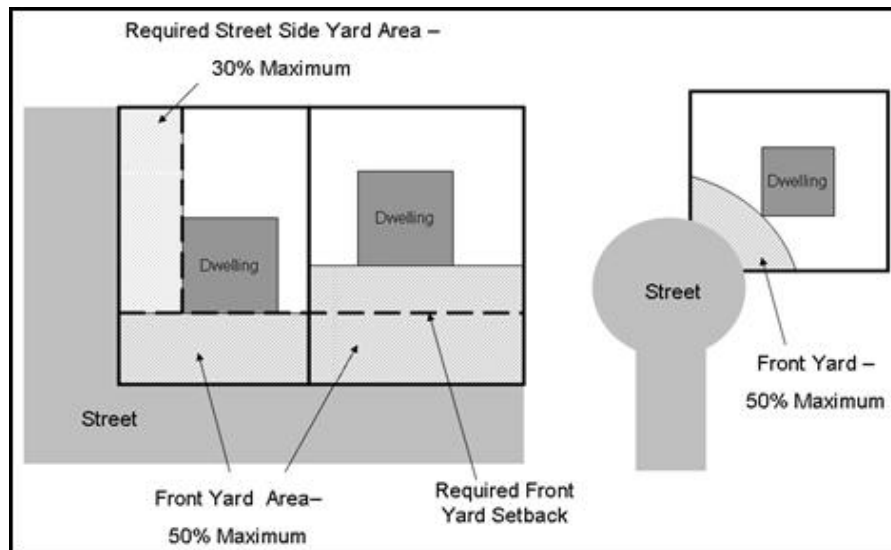

19.607.2 Commercial Vehicle, Pleasure Craft, and Recreational Vehicle Parking

Subsection 19.607.2 is intended to preserve residential neighborhood character by minimizing the impacts created by the parking and storing of commercial vehicles, pleasure crafts, and recreational vehicles. The standards of Subsection 19.607.2 apply to off-street parking areas for cottage clusters, rowhouses, duplexes, triplexes, quadplexes, single detached dwellings, and adult foster/care homes in all zones.

- A. Commercial vehicles shall not be permitted to be parked or stored in the front yard or required street side yard on cottage cluster, rowhouse, duplex, single detached dwelling, or residential home properties. Commercial vehicles may be present anywhere on these properties for up to 12 hours in 1 day if the vehicle is engaged in loading or unloading materials for a residence(s).
- B. Recreational vehicles and pleasure crafts on middle housing, single detached, or adult foster/care home properties must comply with the following regulations:
 - 1. On residential lots less than 1 acre, only 1 recreational vehicle or private pleasure craft that is not located in an enclosed structure such as a garage shall be allowed. Canoes and other crafts less than 12 ft long shall be exempt from this requirement. On lots larger than 1 acre, 1 additional recreational vehicle or private pleasure craft that is not located in an enclosed structure is allowed for each 1/2 acre of area over 1 acre.
 - 2. No vehicle or pleasure craft shall be lived in, have housekeeping maintained, or have hook-up to utilities while parked or stored on, or otherwise attached or moored to, a lot used for middle housing, single detached dwelling, or adult foster/care home.

19.608 LOADING

19.608.2. Number of Loading Spaces

The Planning Manager shall determine whether to require off-street loading for commercial, industrial, public, and semipublic uses. The ratios listed below should be the minimum required unless the Planning Director finds that a different number of loading spaces are needed upon reviewing the loading needs of a proposed use.

A. Residential Buildings

Buildings where all of the floor area is in residential use should meet the following standards:

- 1. Fewer than 50 dwelling units on a site that abuts a local street: no loading spaces required.
- 2. All other buildings: 1 loading space.

B. Nonresidential and Mixed-Use Buildings

Buildings where any floor area is in nonresidential uses should meet the following standards:

- 1. Less than 20,000 sq ft of total floor area: no loading spaces required.
- 2. 20,000 to 50,000 sq ft of total floor area: 1 loading space.
- 3. More than 50,000 sq ft of total floor area: 2 loading spaces.

19.609 BICYCLE PARKING

19.609.1 Applicability

Bicycle parking must be provided for all new commercial, industrial, community service use, cottage-cluster, mixed-use, and multi-unit residential development. Temporary and seasonal uses (e.g., fireworks and Christmas tree stands), single-detached dwellings, plex developments, single-room occupancy housing, townhouses, and adult foster/care homes are exempt from Section 19.609.

This section includes requirements for both short and long-term bicycle parking. Short-term parking facilities include bicycle parking that is convenient, easily accessible, visible to site visitors and occupants, and generally intended for bicycles parked for two hours or less in one location. Long-term bicycle parking facilities are generally only accessible to the users of the parking, are in a secure location, provide protection from the elements, and are intended for bicycles parked for longer than two hours.

19.609.2 Quantity of Spaces

- A. Development must provide the number of bicycle parking spaces as listed in Table 19.609.2. In no case shall less than 2 short-term and 2 long-term spaces be provided, unless specifically stated otherwise. Modifications to the standards in Table 19.609.2 may be made as per Section 19.609.3.
- B. When a specific use has not been proposed or identified at the time of permit review, the Planning Manager may elect to assign a use category from Table 19.609.2 to determine the bicycle parking required. Future tenants or property owners are responsible for compliance with Chapter 19.600 per the applicability provisions of Section 19.602.
- C. If a proposed use is not listed in Table 19.609.2, the Planning Manager has the discretion to apply the quantity requirements of a similar use listed in the table upon finding that the listed use and unlisted use have similar parking demands.
- D. Where the calculation of minimum bicycle parking spaces does not result in a whole number, the result shall be rounded up to the next whole number.

Table 19.609.2: Minimum Required Bicycle Spaces		
Use	Long-term Spaces	Short-term Spaces
A. Residential Uses		
Multi-Unit Residential Development (5 or more units on site)	1.0 per unit	2 or one per 20 units
Cottage Cluster Development	1.5 per unit	0.5 per unit
B. Commercial Uses		
Retail Sales and Services	0.20 per 1000 sq ft of floor area	0.23 per 1000 sq ft of floor area
Retail Restaurants and Bars	0.27 per 1000 sq ft of floor area	0.63 per 1000 sq ft of floor area
Temporary Lodging	0.10 per 1000 sq ft of floor area	0.01 per 1000 sq ft of floor area
Office	0.43 per 1000 sq ft of floor area	0.03 per 1000 sq ft of floor area
Major Event Entertainment	0.07 per 1000 sq ft of floor area	0.20 per 1000 sq ft of floor area

Medical Office (non-hospital)	0.28 per 1000 sq ft of floor area	0.29 per 1000 sq ft of floor area
C. Industrial Uses		
Manufacturing and Production	0.16 per 1000 sq ft of floor area	0.01 per 1,000 sq ft of floor area
Warehouse and Freight Movement	0.08 per 1000 sq ft of floor area	0.003 per 1000 sq ft of floor area
Self-storage or Mini Warehouse	0.005 per 1000 sq ft of floor area	0.018 per 1000 sq ft of floor area
D. Institutional Uses		
Religious Institution	0.07 per 1000 sq ft of floor area	0.44 per 1,000 sq ft of floor area
Daycare	0.26 per 1000 sq ft of floor area	0.03 per 1,000 sq ft of floor area
Elementary or Middle School	2 per classroom	1 per 100,000 sq ft of floor area
High School	4 per classroom	1 per 100,000 sq ft of floor area
College (excluding dormitories)	0.07 per 1000 sq ft of floor area	0.06 per 1000 sq ft of floor area
Library, Museum, Community Center, Performance Theater	0.25 per 1000 sq ft of floor area	0.10 per 1,000 sq ft of floor area
Medical Center or Hospital	0.27 per 1000 sq ft of floor area	0.01 per 1000 sq ft of floor area
Parks and Open Area	None	Neighborhood Parks: 4 per park Community Parks or Natural Areas: 8 per park/area
Transit Center	None	1 space per 100 daily boardings

19.609.3 Bicycle Parking Quantity Modification and Required Parking Determinations

Subsection 19.609.3 allows for the modification of minimum bicycle parking quantities from Table 19.609.2 as well as the determination of minimum bicycle parking requirements when a proposed use is not listed in Table 19.609.2.

A. Applicability

The procedures of Subsection 19.609.3 will apply in the following situations:

1. If the proposed use is not listed in Table 19.609.2 and the quantity requirements for a similar use, as determined by the Planning Manager, cannot be applied.
2. If the applicant seeks a modification from the minimum required quantities as calculated per Table 19.609.2.

B. Application

Determination or modification of bicycle parking ratios in situations listed above shall be reviewed as a Type I land use decision, per Section 19.1004 Type I Review. The application for a determination or modification must include the following:

1. Describe the proposed uses of the site, including information about the size and types of the uses on-site, and information about site users (employees, customers, residents, etc.).

2. Identify factors specific to the proposed use and/or site, such as the proximity of bicycle infrastructure, availability of shared bicycle parking, and/or special characteristics of the customer, client, employee, or resident population that affect bicycle parking demand.
3. Provide data and analysis specified in Subsection 19.609.3.B.3 to support the determination or modification request. The Planning Manager may waive requirements of Subsection 19.609.2.B.3 if the information is not readily available or relevant.
 - a. Analyze bicycle parking demand information from professional literature that is pertinent to the proposed development. Such information may include data or literature from cycling organizations, transportation planning associations, or other relevant sources.
 - b. Present bicycle parking quantity and utilization data from existing developments that are similar to the proposed development. The information about the existing development and its bicycle parking demand must include enough detail to evaluate similarities and differences between the existing development and the proposed development.
 - c. Identify factors specific to the site, such as the availability of secure bicycle parking facilities or the integration of bicycle infrastructure in the vicinity.
4. Propose a minimum bicycle parking ratio. For phased projects or projects where the tenant mix is unknown or subject to change, the applicant may propose a range (low and high number of bicycle parking spaces) for each development phase and a minimum number of bicycle parking spaces to be provided at the completion of the project.
5. Address the approval criteria in Subsection 19.609.3.C.

C. Approval Criteria

The Planning Manager will consider the following criteria in deciding whether to approve the determination or modification. The Planning Manager, based on the applicant's materials and other data the Planning Manager deems relevant, will set the minimum bicycle parking requirement. Conditions of approval may be placed on the decision to ensure compliance with the bicycle parking determination.

1. All modifications and determinations must demonstrate that the proposed bicycle parking quantities are reasonable based on existing bicycle parking demand for similar uses in other locations, bicycle parking requirements for the use in other Portland metropolitan area jurisdictions, and professional literature about the bicycle parking demands of the proposed use.
2. The requested reduction is the smallest reduction needed based on the specific circumstances of the use and/or site or is otherwise consistent with City or Comprehensive Plan policy.
3. In addition to the criteria in Subsection 19.609.2.C.1 and Subsection 19.609.2.C.2, requests for modifications to decrease the amount of minimum required bicycle parking must meet one or more of the following criteria:
 - a. Alternative and Climate-Friendly Transportation Amenities: The development includes other amenities that promote alternative transportation methods, such as secure bicycle sharing programs, on-site electric vehicle charging stations, or carpooling initiatives.
 - b. Specific Demographic Considerations: The targeted demographic for the development has inherent characteristics that make them unlikely to cycle or

start cycling. For example, if the development is primarily frequented by or developed for older residents or individuals with disabilities, who may have limited mobility options, the need for extensive bicycle parking could be reduced.

- c. **Comprehensive Bicycle Infrastructure Plan:** The applicant can propose a comprehensive bicycle infrastructure plan that outlines future measures to enhance bicycle accessibility and promote cycling within the development or the surrounding area. This plan could include commitments to improve signage, create bike-sharing programs, or establish connections to existing cycling networks. By demonstrating a long-term commitment to bicycle infrastructure, the applicant may be granted a reduction in current parking requirements.
- d. **Availability of Future Expansion Space:** If the applicant can demonstrate that there is available space within the development that can be easily converted to additional bicycle parking in the future, they could be allowed a reduction in the current requirement.
- e. **Proximity to Existing Bicycle Infrastructure:** The development is located in close proximity to well-established bicycle parking, such as ample existing short-term bicycle parking, or previously established shared long-term parking in a multi-tenant space/development. This assumes that users of the new facility can easily access existing parking and may not need additional on-site parking.

19.609.4 Bicycle Parking Development Standards

A. General Development Standards for Bicycle Parking

Long-term and short-term bicycle parking must be provided in lockers or racks that meet the following standards:

- 1. The area devoted to bicycle parking must be hard-surfaced.
- 2. Where bicycle parking is provided in racks, the racks must meet the following standards:
 - a. The rack must be designed so that the bicycle frame and one wheel can be locked to a rigid portion of the rack with a U-shaped shackle lock when both wheels are left on the bicycle.
 - b. If the rack is a horizontal rack, it must support the bicycle at two points, including the frame.
 - c. The rack must be securely anchored with tamper-resistant hardware.
- 3. Bicycle parking spaces, aisles, and clearances must meet the minimum dimensional standards contained in Table 19.609.4.A.3. See examples of bicycle parking spacing options in Figures 19.609.4.A.3.a-g.

Table 19.609.4					
Minimum Bicycle Parking Space Dimensions					
	Length	Width	Height	Maneuvering Area Width	Clearance to rack from walls
Standard Spacing	6 ft	2 ft	3 ft 4 in	5 ft	2 ft 6 in

Horizontal Side by Side	6 ft	1 ft 6 in	3 ft 4 in	5 ft	2 ft 6 in
Horizontal Wall Attached	6 ft	2 ft	3 ft 4 in	5 ft	1 ft
Horizontal Diagonal (45-60 degrees)	6 ft	1 ft 6 in	3 ft 4 in	5 ft	3 ft
Vertical Spaces [1]	3 ft 4 in	1 ft 5 in	6 ft	5 ft	-
Stacked Spaces [2]	-	1 ft 5 in	-	8 ft	-
Larger Bicycle Space	8 ft	3 ft	3 ft 4 in	5 ft	3 ft

1. The spacing allowed for vertical bicycle parking spaces requires a minimum vertical stagger of 8 inches between each space.
2. The spacing for stacked bicycle parking requires a vertical stagger to be included in the manufacturer's design.

**Figure 19.609.4.A.3.a
Standard Bicycle Parking**

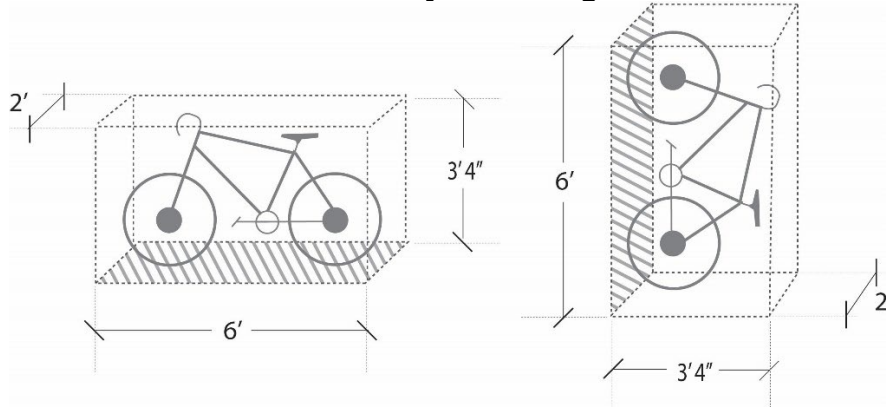

**Figure 19.609.4.A.3.b
Horizontal Side-by-Side Bicycle Parking**

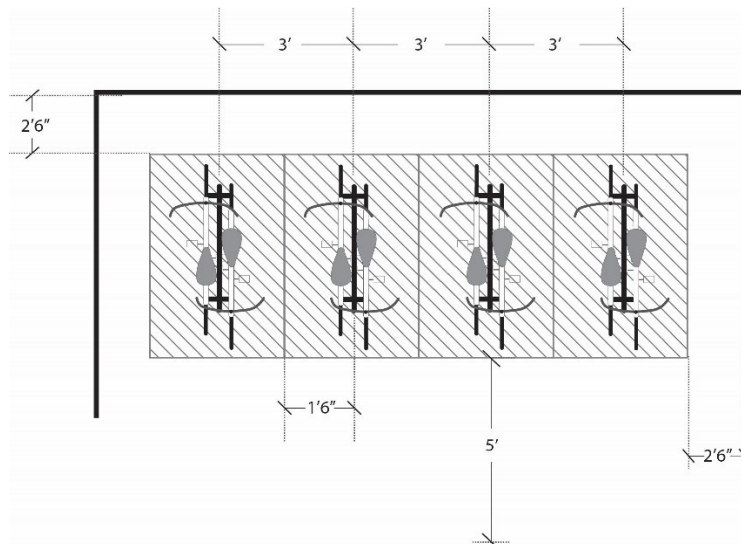

Figure 19.609.4.A.3.c
Horizontal Wall Attached Bicycle Parking

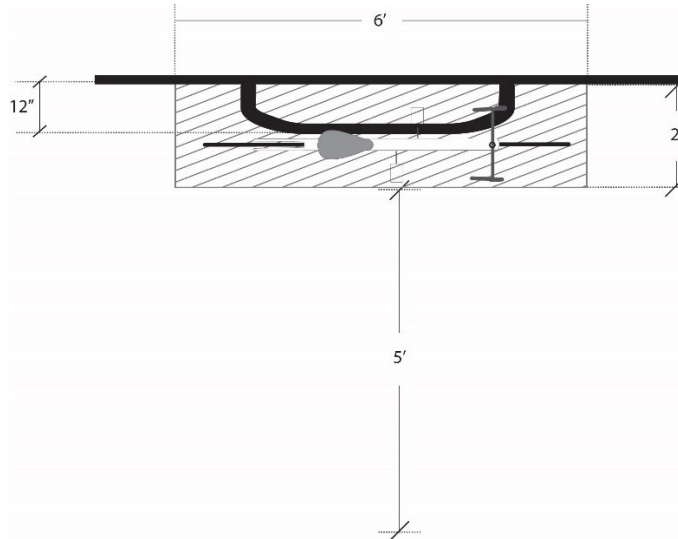

Figure 19.609.4.A.3.d
Horizontal Diagonal (45-60 degree) Bicycle Parking

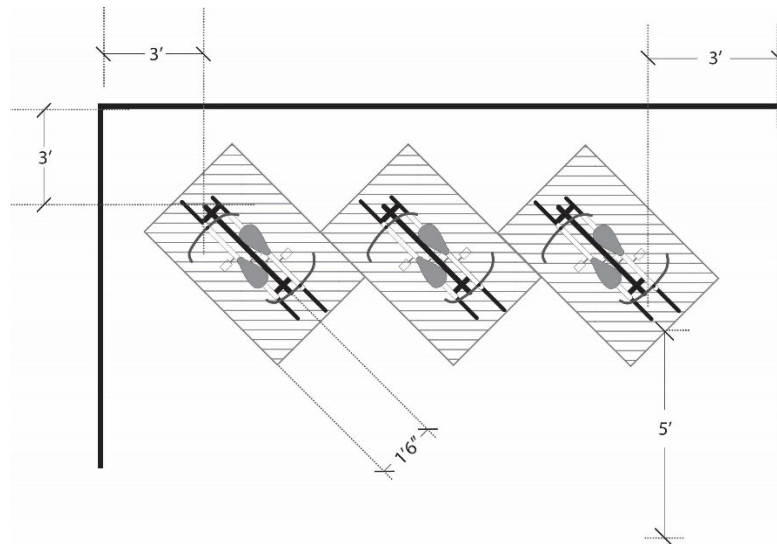

Figure 19.609.4.A.3.e
Vertical Bicycle Parking

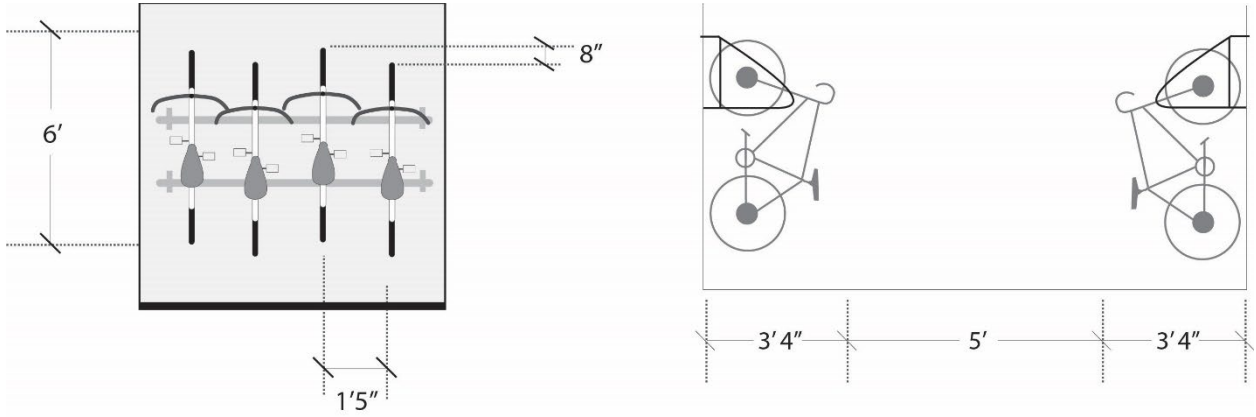

Figure 19.609.4.A.3.f
Stacked Bicycle Parking

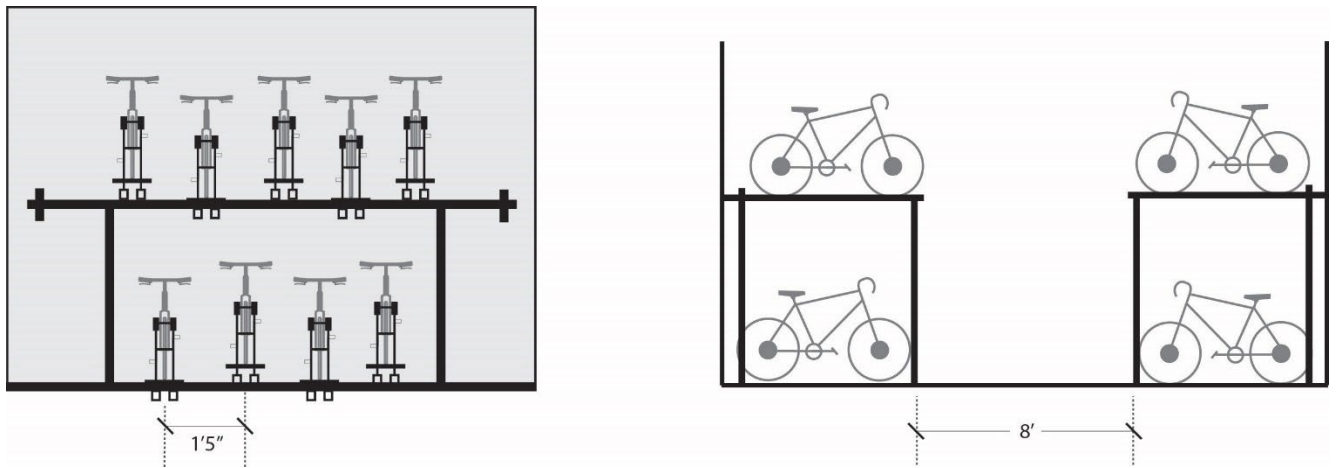
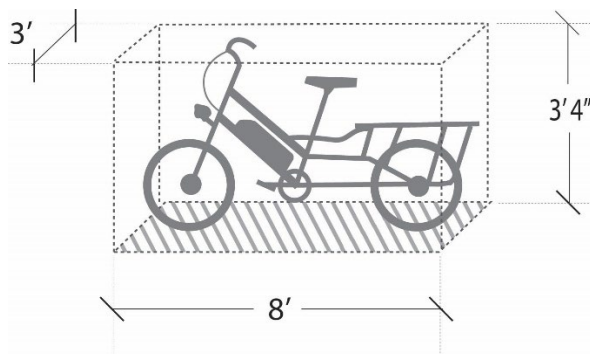

Figure 19.609.4.A.3.g
Large Bicycle Parking Space



4. Bicycle lockers are fully enclosed and secure bicycle parking spaces that meet the following standards:
 - a. The locker must be securely anchored to the ground.
 - b. Locker spaces must have a minimum depth of 6 ft and an access door that is at least 2 ft wide. If providing more than one bicycle parking space through a triangle locker layout, a 2 ft wide door must be provided on each side of the locker.
5. The following bicycle parking information must be submitted with applications for a building permit or land-use review:
 - a. Location and number of bicycle parking spaces for short- and long-term bicycle parking along with the access route to long-term bicycle parking.
 - b. The model or design of the bicycle parking facilities to be installed.
 - c. Dimensions of all aisles and maneuvering areas.

B. Standards for Long-Term Bicycle Parking

In addition to the general standards established in Subsection 19.609.4.A, long-term bicycle parking must be provided in lockers or racks that meet the following standards:

1. Locational Standards. Long-term bicycle parking must be provided in one or more of the following locations:
 - a. Within a building, including on individual building floors.
 - b. On-site, including in parking areas and structured parking.
 - c. Within a residential dwelling unit. Up to 50% of long-term bicycle parking spaces may be provided within a residential dwelling unit if they meet the following requirements:
 - (1) Parking space must include a rack that meets the dimensional requirements for a standard bicycle rack per Table 19.609.4.
 - (2) For multifamily and mixed-use developments without an elevator, in-unit long-term bicycle parking can only be located on the ground floor.
 - d. Exceptions. Sites containing residential development with 12 or fewer dwelling units may provide up to 100% of required long-term bicycle parking spaces in dwelling units. All other applicable standards in MMC Subsection 19.609.4.B must still be met, including the prohibition of in-unit bicycle parking on upper floors unless the building has an elevator.
 - e. For schools, all long-term bicycle parking must be placed within the building on the ground floor, within 100 ft of a main entrance, or some combination of the two.
 - f. For sites with multiple primary uses, long-term bicycle parking must be provided in an area that can be accessed from each use. If bicycle parking is provided in a common area on the site, the area must be accessible to all tenants.
 - g. All long-term bicycle parking must be covered. Where covered bicycle parking is not within a building or locker, the cover must be permanent, impervious to precipitation, and project a minimum of 2 ft beyond the bicycle parking spaces on the portion of the structure that is not enclosed by a wall.
2. Security Standards. Long-term bicycle parking must meet the following security standards:

- a. Long-term bicycle parking for residential uses must be provided within one of the following:
 - (1) A restricted access, lockable room or enclosure, designated primarily for bicycle parking.
 - (2) A bicycle locker.
 - (3) A residential dwelling unit, subject to the limitations in MMC Subsection 19.906.4.B.1.c.
- b. Long-term bicycle parking for all other uses must be located in one of the following locations.
 - (1) A restricted access, lockable room or enclosure.
 - (2) A bicycle locker.

3. Additional Development Standards. The following standards apply to sites with more than 20 long-term bicycle parking spaces:

- a. Minimum number of horizontal bicycle parking spaces. At least 30% of spaces must be in a horizontal rack, or on the lower level of a stacked bicycle parking rack. For elementary and middle schools (K-8), all spaces located outside of the building must be in a horizontal rack.
- b. Parking for larger bicycles. At least 5% of spaces must accommodate a larger bicycle space, placed in a horizontal rack. These spaces may be included to meet the minimum percentage requirements for Subparagraph B.3.a. See Figure 19.609.4.A.7.
- c. Electrical outlet requirement. At least 5% of spaces must be located within 10 ft of an electrical socket. Each electrical socket must be accessible to horizontal bicycle parking spaces.

C. Standards for Short-Term Bicycle Parking

In addition to the general standards established in Subsection 19.609.4.A, short-term bicycle parking must meet the following standards:

- 1. Short-term bicycle parking must meet the following locational requirements:
 - a. Be located on-site, outside of a building.
 - b. Must be at the same grade as the sidewalk or at a location that can be reached by an accessible route.
 - c. Be located within 50 ft of the main entrance, or for buildings with multiple main entrances, must be dispersed and located within 50 ft of the main entrance on each façade. For sites with multiple primary buildings, short-term parking must be dispersed and located within 50 ft of the main entrance for each primary building.
 - d. Must be visible to building occupants.
 - e. Must be designed not to impede pedestrians along sidewalks or public rights-of-way.
 - f. If located adjacent to automobile parking, must be separated from vehicle parking areas by curbing or other similar physical barriers.
- 2. The public right-of-way may be utilized for bicycle parking when parking cannot be reasonably accommodated on the site and the location is convenient to the building's front entrance. The bicycle parking area in the right-of-way must leave a clear,

unobstructed width of sidewalk that meets the Engineering Department's Public Works Standards for sidewalk passage. See Figure 19.609 for illustration of space and locational standards. A right-of-way permit is required.

Figure 19.609.4.C.2
Bicycle Parking in the Public Right-of-Way

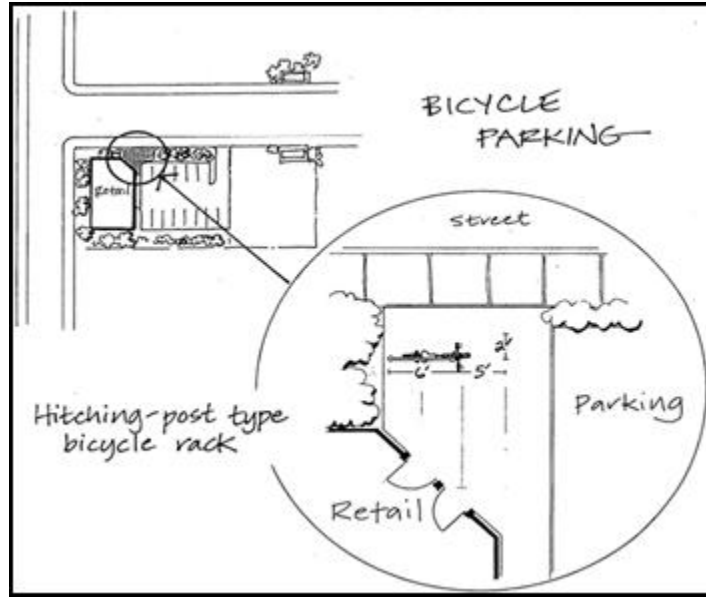

19.610 CARPOOL AND VANPOOL PARKING

19.610.2 Number of Spaces

The number of carpool/vanpool parking spaces shall be at least 10% of the minimum amount of parking spaces provided.

19.611 PARKING STRUCTURES

The purpose of Section 19.611 is to regulate the design and location of structured parking, and to provide appropriate incentives for the provision of structured parking. Structured parking is allowed to accommodate parking for a specific use, or as a parking facility that is a use by itself.

19.611.1 Permitted Zones and Review Procedures

- A. Parking structures, including underground parking, are allowed in all zoning districts except the Moderate Density Residential and Open Space Zones. A parking structure can be permitted through approval of a Community Service Use application in all zones except the Open Space Zone. A parking structure to be used for commercial parking in the Downtown Mixed Use Zone must be permitted through approval of a conditional use application.

19.611.2 Compliance with Other Sections of Chapter 19.600

- A. Spaces in parking structures are exempt from counting against maximum parking allowances if the spaces are utilized for types of parking listed in Subsection 19.605.3.A.

CHAPTER 19.900 LAND USE APPLICATIONS

19.901 INTRODUCTION

Uses or development that are regulated by Titles 14, 17, and 19 of the Milwaukie Municipal Code shall submit and obtain approval for all required land use applications prior to establishment or construction. Table 19.901 below contains a complete list of the City’s land use applications and the location of the provisions that govern their submittal, review, and approval. It also identifies the review type(s) associated with each application type. The review type determines who is given notice about land use and development proposals, when the City has to make a decision on a land use application, and who makes the final decision. Descriptions of the different review types and the procedures associated with them are located in Chapter 19.1000. Decision makers for each review type are listed in Table 19.1001.5.

Table 19.901 Land Use Applications		
Application Type	Municipal Code Location	Review Types
Parking:	Chapter 19.600	
Quantity Determination	Subsection 19.605.2	II
Quantity Modification	Subsection 19.605.2	II
Structured Parking	Section 19.611	II, III

19.905 CONDITIONAL USES

19.905.5 Conditions of Approval

The Planning Commission, or Planning Manager in the case of minor modifications, may impose conditions of approval that are suitable and necessary to assure compatibility of the proposed use with other uses in the area and minimize and mitigate potential adverse impacts caused by the proposed use.

Conditions of approval may include, but are not limited to, the following aspects of the proposed use:

- A. Limiting the hours, days, place, and manner of operation.
- B. Requiring structure and site design features that minimize environmental impacts such as those caused by noise, vibration, air pollution, glare, odor, carbon emissions, and dust.
- C. Requiring additional front, rear, or side yard width.
- D. Limiting building height, size, or location or limiting lot coverage.
- E. Limiting or otherwise designating the size, number, or location of vehicle access points from the street.
- F. Requiring additional landscaping or screening of off-street parking and loading areas.

- G. Limiting or otherwise designating the location, intensity, and shielding of outdoor lighting.
- H. Requiring screening or landscaping for the protection of surrounding properties.
- I. Requiring and designating the size, height, location, and materials for fences.
- J. Requiring the protection and preservation of existing trees, soils, vegetation, watercourses, habitat areas, and drainage areas.
- K. Requiring adequate public transportation facilities and public utilities prior to occupancy.

19.910 RESIDENTIAL DWELLINGS

19.910.3 Manufactured Dwelling Parks

D. Development Requirements

All manufactured dwelling parks shall meet the following minimum requirements:

- 7. When provided, off-street parking and recreational vehicle parking shall be developed as per Chapter 19.600.