



COUNCIL RESOLUTION No. 41-2022

**A RESOLUTION OF THE CITY COUNCIL OF THE CITY OF MILWAUKIE, OREGON,  
ADOPTING THE 2021 WASTEWATER SYSTEM MASTER PLAN (WWSMP).**

**WHEREAS** the city contracted with Water Systems Consulting, Inc., to update the 2010 Wastewater System Master Plan (WWSMP), and

**WHEREAS** the city's public works department prepared the 2021 WWSMP with input from the engineering department, planning department, and Citizen's Utility Advisory Board (CUAB), and

**WHEREAS** the 2021 WWSMP establishes projects for the wastewater system that are necessary for the ongoing provision of wastewater utility services in the city, and

**WHEREAS** it is necessary to document future projects for the wastewater system for the ongoing provision of wastewater services to determine the costs of maintaining the wastewater system.

**Now, Therefore, be it Resolved** by the City Council of the City of Milwaukie, Oregon, that the 2021 Wastewater System Master Plan (WWSMP) is adopted.

Introduced and adopted by the City Council on **June 7, 2022**.

This resolution is effective immediately.

Mark Gamba, Mayor

ATTEST:

APPROVED AS TO FORM:

Scott Stauffer, City Recorder

Justin D. Gericke, City Attorney



**WASTEWATER SYSTEM**  
MASTER PLAN UPDATE



# Wastewater System Master Plan Update

Prepared for:

## City of Milwaukie



Prepared Under the Responsible Charge of:

Scott Duren, PE



5/6/2022



# Acknowledgements

Water Systems Consulting, Inc. would like to acknowledge the significant contributions of the City of Milwaukie, including the following staff.

Peter Passarelli, Public Works Director

Shane Hart, Wastewater/Stormwater Supervisor

Chris Calhoun, Wastewater Lead Utility Technician

Dave Butcher, Asset Management Technician

Nicholas Lindekugel, GIS Coordinator

Jennifer Garbely, Assistant City Engineer

Natalie Rogers, Climate Action and Sustainability Coordinator

Denny Egner, City Planner (retired)

The City of Milwaukie Wastewater System Master Plan Update was prepared by Water Systems Consulting, Inc. The primary authors are listed below.



Scott Duren, P.E.

Adam Donald, P.E.

Jeroen Olthof, P.E.

Spencer Waterman

Kirsten Plonka

Jeff Lawrence



Water Systems Consulting, Inc. received assistance in the preparation of the City of Milwaukee's Wastewater System Master Plan Update from the following subconsultants:

**SFE Global**



Mike Lemmen

Glenn Cumyn

Dylan Carvin

**FCS Group**



Doug Gabbard

John Ghilarducci

Zechariah Hazel

**McMillen Jacobs Associates**



Wolfe Lang, P.E., G.E.

Luke Ferguson, P.E.

**SEFT Consulting Group**



Kent Yu, P.E., S.E.

Jim Newell, PhD, P.E., S.E.

# Table of Contents

Acknowledgements.....	ii
Table of Contents .....	iv
List of Tables .....	ix
List of Figures .....	xi
Glossary of Terms.....	xiii
<b>1 Executive Summary.....</b>	<b>1-1</b>
1.1 Objectives.....	1-1
1.2 System Description .....	1-2
1.3 Agreements, Rules, and Regulations .....	1-2
1.4 System Loading .....	1-3
1.5 Hydraulic Analysis .....	1-4
1.6 Rainfall Dependent Infiltration and Inflow .....	1-5
1.7 Asset Rehabilitation and Replacement .....	1-6
1.8 System Resilience.....	1-7
1.9 Capital Improvement Program .....	1-8
<b>2 Introduction .....</b>	<b>2-1</b>
2.1 Objectives.....	2-1
2.2 Authorization .....	2-2
2.3 Relationship to Other Documents and City Programs .....	2-2
2.4 City Overview .....	2-3
2.4.1 Location .....	2-3
2.4.2 Topography .....	2-5
2.4.3 Climate .....	2-5
2.4.4 Population .....	2-5
2.4.5 Land Use .....	2-5
<b>3 Existing Wastewater System.....</b>	<b>3-1</b>

3.1	Existing Service Area .....	3-1
3.1.1	Wastewater Treatment .....	3-1
3.2	Sewer Basins .....	3-3
3.2.1	North Milwaukie Basin .....	3-3
3.2.2	Mid Milwaukie Basin .....	3-3
3.2.3	South Milwaukie Basin .....	3-5
3.2.4	Harmony Basin .....	3-5
3.2.5	Brookside Basin .....	3-7
3.2.6	Johnson Creek Basin.....	3-7
3.2.7	Lower Kellogg Basin.....	3-7
3.3	System Inventory .....	3-7
3.3.1	Gravity Pipelines and Manholes.....	3-7
3.3.2	Sewage Pump Stations and Force Mains .....	3-9
3.3.3	Inverted Siphons .....	3-10
3.4	Maintenance Activities and Programs .....	3-10
3.5	Data Systems and Information Management.....	3-10
4	Agreements, Rules, and Regulations .....	4-1
4.1	Interagency Agreements.....	4-1
4.1.1	Clackamas WES .....	4-1
4.1.2	City of Portland.....	4-2
4.1.3	Oak Lodge Water Services District .....	4-2
4.2	Rules and Regulations .....	4-2
4.2.1	Oregon Administrative Rule, Chapter 660 .....	4-3
4.2.2	Oregon Administrative Rule, Chapter 340 .....	4-3
4.2.3	Oregon Revised Statute, Chapter 224.....	4-3
4.2.4	Oregon Revised Statute, Chapter 223.....	4-3
5	Flows & Loads .....	5-1
5.1	Historic and Future Population Growth.....	5-1
5.1.1	Population Per Household .....	5-1
5.1.2	Buildout Development .....	5-2
5.1.3	Future Population Projections .....	5-2

5.2	Elements of Total Wastewater Flow.....	5-3
5.3	Existing Flow Development.....	5-4
5.3.1	Flow Monitoring.....	5-4
5.3.2	Existing Dry Weather Flow.....	5-7
5.3.3	Existing Wet Weather Flow.....	5-10
5.3.4	Rainfall Dependent Inflow and Infiltration (RDII).....	5-13
5.4	Future Flow and Load Development.....	5-14
5.4.1	Future Dry Weather Flow.....	5-15
5.4.2	Future Wet Weather Flow.....	5-17
6	Hydraulic Model Development.....	6-1
6.1	Model Development.....	6-1
6.1.1	City GIS Data.....	6-1
6.1.2	Manually Entered Data.....	6-2
6.2	Model Loading.....	6-6
6.3	Model Calibration.....	6-7
6.3.1	Dry Weather Flow Verification.....	6-7
6.3.2	Wet Weather Flow Development.....	6-9
7	Hydraulic Capacity.....	7-1
7.1	Capacity Evaluation Criteria.....	7-1
7.2	Capacity Deficiency.....	7-2
7.2.1	Existing Loading Conditions.....	7-2
7.2.2	Sewers Under 2040 Loading.....	7-4
7.2.3	Sewers Under Buildout Loading.....	7-5
7.2.4	Recommended Capacity Improvements.....	7-7
7.3	Clackamas WES RDII Reduction Program.....	7-16
7.3.1	Program Overview.....	7-16
7.3.2	Existing RDII.....	7-19
7.3.3	Future RDII.....	7-20
7.3.4	RDII Reduction.....	7-20
7.4	Project Recommendations.....	7-21
8	Condition Evaluation.....	8-1



8.1	Current Condition Assessment Practices .....	8-1
8.2	Existing Pipeline Condition Data .....	8-2
8.3	Existing Condition Deficiencies .....	8-2
8.4	Prioritization Methodology .....	8-3
8.4.1	Consequence of Failure .....	8-5
8.4.2	Likelihood of Failure .....	8-8
8.4.3	Risk Prioritization .....	8-10
8.5	Pump Stations .....	8-13
8.6	Renewal Strategy .....	8-14
8.6.1	Identification of Repairs to be Completed by City Crews .....	8-14
8.6.2	Recommended Condition-Based Projects.....	8-15
8.6.3	Optimizing CCTV Inspections .....	8-16
8.6.4	Sewer Pump Station Assessment .....	8-17
8.6.5	Projects from the 2010 WWSMP .....	8-18
8.7	Project Recommendations.....	8-18
9	System Resilience.....	9-1
9.1	Seismic Resilience .....	9-1
9.1.1	Level of Service Goals.....	9-2
9.1.2	Critical Infrastructure .....	9-2
9.1.3	Seismic Geohazards.....	9-5
9.1.4	Collection Sewer Pipeline Risk Analysis .....	9-11
9.1.5	Pump Station Risk Analysis.....	9-15
9.1.6	Seismic Mitigation Plan/Recommendations .....	9-15
9.2	Climate Resilience .....	9-20
9.2.1	Sea Level Rise .....	9-20
9.2.2	Climate Impacts from Growth.....	9-25
9.2.3	Urban Tree Planting .....	9-25
9.2.4	Climate Related Design Standards .....	9-25
10	Capital Improvement Program .....	10-1
10.1	Methodology.....	10-1
10.1.1	Cost Estimating Basis and Assumptions .....	10-2

10.1.2	System Development Charges .....	10-2
10.1.3	Project Scheduling and Prioritization .....	10-3
10.2	Recommended Capital Improvement Program .....	10-4
10.3	Capital Improvement Projects .....	10-4
10.3.1	Capacity Projects .....	10-4
10.3.2	Condition Projects .....	10-6
10.3.3	Resilience Projects.....	10-6
10.3.4	Planning Projects.....	10-6
10.4	Funding and Financing .....	10-7
10.4.1	Rates and SDCs.....	10-7
10.4.2	Bonds.....	10-7
10.4.3	Grants and Loans.....	10-7
10.5	Summary .....	10-8
11	References .....	11-1
	Appendix A. Intergovernmental Agreement with Clackamas WES .....	A
	Appendix B. Intergovernmental Agreement with City of Portland .....	B
	Appendix C. Intergovernmental Agreement with Oak Lodge Water Services.....	C
	Appendix D. Buildable Lands Inventory Technical Memorandum.....	D
	Appendix E. Flow Monitoring Technical Memorandum .....	E
	Appendix F. NASSCO PACP Defect Scoring .....	F
	Appendix G. Prioritized List of Mains.....	G
	Appendix H. Level of Service Technical Memorandum .....	H
	Appendix I. Lift Station Evaluation Technical Memorandum .....	I
	Appendix J. Detailed Cost Estimates.....	J
	Appendix K. System Development Charge Technical Memorandum .....	K
	Appendix L. Map of CIP Projects .....	L

# List of Tables

Table 1-1. Current and Future Projected Loading .....	1-3
Table 1-2. Hydraulic Performance Criteria for Evaluation of System Capacity .....	1-4
Table 1-3. RDII Reduction Targets Under Clackamas WES Program.....	1-5
Table 1-4. Existing RDII.....	1-6
Table 1-5. Capital Improvement Program Summary .....	1-9
Table 2-1. Climate Data for Milwaukie, OR (6) .....	2-5
Table 3-1. Lift Station Summary Table .....	3-9
Table 5-1. Population Per Household in Milwaukie City Limits .....	5-1
Table 5-2. Buildout Population .....	5-2
Table 5-3. Historical and Projected Population Growth for the City of Milwaukie .....	5-2
Table 5-4. Dry Weather Flow Monitoring Results .....	5-5
Table 5-5. Peaking Factors by Flow Monitoring Basin .....	5-7
Table 5-6. Average Dry Weather Flow by Basin.....	5-10
Table 5-7. Past Master Plan Flow Factors .....	5-10
Table 5-8. Top Ten Rain Events (24 Hour) by Total Rain During Wet Weather Flow Monitoring .....	5-11
Table 5-9. RTK Parameters for Unmonitored Areas .....	5-13
Table 5-10. Peak Wet Weather Flow Under Storm Conditions .....	5-14
Table 5-11. RDII by Flow Monitoring Basin.....	5-14
Table 5-12. Future Dry Weather Flow .....	5-15
Table 5-13. Loading by Zone Type .....	5-16
Table 5-14. Wet Weather Flow for the Year 2040.....	5-17
Table 5-15. Buildout Wet Weather Flow .....	5-18
Table 6-1. Model/GIS Attributes.....	6-2
Table 6-2. Summary of Manual Adjustments to Pipe Invert Data .....	6-3
Table 6-3. Summary of Dry Weather Flow Verification .....	6-8
Table 6-4. Dry Weather Flow Verification Results .....	6-9
Table 6-5. Wet Weather Flow Verification Criteria .....	6-9
Table 6-6. Wet Weather Flow Verification Results.....	6-10
Table 7-1. Hydraulic Capacity Evaluation Criteria.....	7-2
Table 7-2. Existing Manholes Not Meeting Primary Evaluation Criteria .....	7-3
Table 7-3. Pump Station Results Under Existing Loading .....	7-3
Table 7-4. Pump Station Results Under 2040 Loading.....	7-4
Table 7-5. 2040 Manholes Not Meeting Primary Evaluation Criteria.....	7-5
Table 7-6. Buildout Manholes Not Meeting Primary Evaluation Criteria .....	7-6

Table 7-7: Pump Station Results Under Buildout Loading .....	7-7
Table 7-8: Pipeline Capacity Upgrades .....	7-12
Table 7-9: Brookside Manhole Hydraulic Improvements (2040 Loading) .....	7-13
Table 7-10: RDII Reduction Targets Under Clackamas WES Program.....	7-16
Table 7-11. WES Calculated RDII and Projected Future Rates for City of Milwaukie .....	7-17
Table 7-12: Existing Peak RDII .....	7-19
Table 7-13: Capacity Based Projects .....	7-21
Table 8-1: Existing System PACP Scoring Summary .....	8-3
Table 8-2: COF Evaluation Criteria .....	8-5
Table 8-3: COF Score by Pipe Diameter .....	8-5
Table 8-4: COF Score by Pipe Depth .....	8-6
Table 8-5: COF Score by Road Type .....	8-6
Table 8-6: COF Scores Based on Seismic Backbone .....	8-7
Table 8-7: COF Scores Based on Distance from Water Bodies .....	8-7
Table 8-8: COF Score Weighting .....	8-8
Table 8-9: Installation Dates by Sewer Basin per 1994 SFP (1).....	8-10
Table 8-10: LOF Based on Remaining Useful Life.....	8-10
Table 8-11: Risk Prioritization Tiers .....	8-10
Table 8-12. Pump Station Construction and Refurbishment History .....	8-13
Table 8-13. City Analysis of CCTV for Point Repair Pipes .....	8-14
Table 8-14. Estimated City-wide Repair Rates .....	8-15
Table 8-15. Proposed CCTV Inspection Frequency .....	8-16
Table 8-16: Pump Station Condition Repair Needs .....	8-17
Table 8-17. Summary of Condition-Based Project Recommendations.....	8-19
Table 9-1: Wastewater Level of Service Goals (22) .....	9-3
Table 9-2: Seismic Hazards for Critical Facilities .....	9-11
Table 9-3: Pipeline Fragility Constants.....	9-12
Table 9-4: Preliminary Pump Station Seismic Retrofit Recommendations.....	9-15
Table 9-5: Programmatic Seismic Retrofit Recommendations for Sewer Pipes.....	9-16
Table 9-6: Updates to Public Works Standards .....	9-19
Table 9-7: Recommended Seismic Resilience Pump Station Projects .....	9-20
Table 9-8: Sea Level Rise Tool Parameters .....	9-21
Table 9-9: Recommended Climate Resilience Projects.....	9-22
Table 10-1. Capital Improvement Program Implementation .....	10-5



# List of Figures

Figure 2-1: Location Map .....	2-4
Figure 3-1 – City of Milwaukie Service Area .....	3-2
Figure 3-2: Collection System Sewer Basins .....	3-4
Figure 3-3: Customers Served by Oak Lodge Water Services .....	3-6
Figure 3-4: Gravity Pipe Length by Diameter in Inches.....	3-9
Figure 3-5: Mains Requiring Quarterly Maintenance .....	3-12
Figure 5-1: Components of Wastewater Flow (15).....	5-4
Figure 5-2: Flow Monitoring Locations and Tributary Area .....	5-6
Figure 5-3: Diurnal Curve for Flow Monitor 3 .....	5-8
Figure 5-4: RTK Unit Hydrograph Parameters (15) .....	5-12
Figure 5-5: Comparison of Storm Hyetographs .....	5-13
Figure 6-1: Sample Segment with Connectivity Issue.....	6-4
Figure 6-2: Sample Segment with Corrected Connectivity .....	6-4
Figure 6-3: Modeling Siphons .....	6-5
Figure 6-4. Johnson Creek Siphon Inlet Structure .....	6-6
Figure 6-5: Assigning Property Connection Loads in the Model.....	6-7
Figure 6-6: Dry Weather Flow Verification Hydrograph at Flow Monitor 1 .....	6-8
Figure 6-7: Wet Weather Hydrograph at FM 3 During January 27-28 Storm .....	6-11
Figure 7-1: Hydraulic Capacity Evaluation Results Under Existing Loading .....	7-9
Figure 7-2: Hydraulic Capacity Evaluation Results Under 2040 Loading .....	7-10
Figure 7-3: Hydraulic Capacity Evaluation Results Under Buildout Loading.....	7-11
Figure 7-4: Recommended Pipeline Projects.....	7-15
Figure 7-5: WES Basins within the City .....	7-18
Figure 8-1: Mains with PACP Scores at Time of Analysis .....	8-4
Figure 8-2: Risk Prioritization for Sewer Pipes.....	8-12
Figure 9-1: Sanitary Sewer Backbone Infrastructure .....	9-4
Figure 9-2: Peak Ground Velocity for M9.0 CSZ Earthquake .....	9-7
Figure 9-3: Liquefaction Settlement PGD for M9.0 CSZ Earthquake .....	9-8
Figure 9-4: Liquefaction Lateral Spreading PGD for M9.0 CSZ Earthquake .....	9-9
Figure 9-5: Seismic Landslide PGD for M9.0 CSZ Earthquake .....	9-10
Figure 9-6: Estimated Repair Rates for the Backbone Collection System .....	9-13
Figure 9-7: Estimated Repair Rates for the City's Collection System.....	9-14
Figure 9-8: Seismic Risk Prioritization .....	9-18
Figure 9-9: Sea Level Rise Impacts on the City of Milwaukie (24) .....	9-23

Figure 9-10: Collection System Infrastructure Impacted By Sea Level Rise.....9-24

# Glossary of Terms

ADA	Americans with Disabilities Act
ADWF	Average Dry Weather Flow
ALA	American Lifelines Alliance
BLI	Buildable Lands Inventory
BWF	Base Wastewater Flow
CCI	Construction Cost Index
CCTV	Closed Circuit Television
CIP	Capital Improvement Program
CIPP	Cured In Place Pipe
City	City of Milwaukie
COF	Consequence of Failure
CSZ	Cascadia Subduction Zone
CWSRF	Clean Water State Revolving Fund
DEQ	Department of Environmental Quality
DIP	Ductile Iron Pipe
DOGAMI	Department of Geology and Mineral Industries
DWF	Dry Weather Flow
EDU	Equivalent Dwelling Unit
ENR	Engineering News Record
FM	Flow monitor
ft	Feet
FY	Fiscal Year
GIS	Geographic Information Systems
gpad	Gallons Per Acre Per Day
gpd	Gallons Per Day
Gpm	Gallons per minute
GW	Ground Water Infiltration
HDPE	High-Density Polyethylene
HP	Horsepower
IGA	Intergovernmental Agreement
LF	Linear feet
LOF	Likelihood of Failure

---

LOS	Level of Service
M9.0	Magnitude 9.0
MACP	Manhole Assessment Certification Program
MGD	Million Gallons per Day
MJA	McMillen Jacobs Associates
MSL	Mean seal level
NASSCO	National Association of Sewer Service Companies
NHMP	National Hazard Mitigation Plan
NPDES	National Pollutant Discharge Elimination System
Oak Lodge	Oak Lodge Water Services
OAR	Oregon Administrative Rule
ORS	Oregon Revised Statutes
PACP	Pipeline Assessment Certification Program
PGD	Peak ground deformation
PGV	Peak ground velocity
PSU	Portland State University
PVC	Polyvinyl Chloride
PWWF	Peak Wet Weather Flow
RDII	Rainfall Dependent Infiltration & Inflow
RUL	Remaining Useful Life
SAFE	Safe Access For Everyone
SCADA	Supervisory Control and Data Acquisition
SCS	Soil and Conservation Service
SDC	System Development Charge
SFP	Sewerage Facilities Plan
SSO	Sanitary Sewer Overflow
SSSMP	Sanitary Sewer System Master Plan
TMDL	Total Maximum Daily Load
UGMA	Urban Growth Management Area
WES	Water Environment Services
WRRF	Water Resource Recovery Facility
WSC	Water Systems Consulting
WWF	Wet Weather Flow
WWSMP	Wastewater System Master Plan



## CHAPTER 1

# Executive Summary

The City of Milwaukie (City) owns and operates a wastewater collection system that serves approximately 21,000 residents and commercial customers within the City limits as well as a small number of customers located in the Oak Lodge Water Service District service area. This Wastewater System Master Plan (WWSMP) updates the previous plan developed in 2010 to assess the ability of the system to meet the needs of current and future customers and recommends a capital improvement program (CIP) to guide investments over a 20-year planning horizon.

## 1.1 Objectives

The City contracted with Water Systems Consulting, Inc. (WSC) to develop a WWSMP update through a planning horizon of 2040. During the process of preparing the updated WWSMP, the City identified the following objectives:

- Plan for growth from increased residential density
- Plan for expansion of the City's service area within the Urban Growth Management Area
- Develop an accurate hydraulic model of the collection system
- Identify the level of rainfall dependent infiltration and inflow (RDII) within the collection system
- Understand capacity limitations at the Kellogg Water Resource Recovery Facility (WRRF)
- Identify existing and future system capacity and condition deficiencies
- Assess the City's vulnerability to seismic events and climate change
- Align the WWSMP with parallel City initiatives to address climate change and affordability
- Develop a prioritized list of improvements to address deficiencies and vulnerabilities

---

### IN THIS SECTION

Objectives

System Description

Agreements, Rules, and Regulations

System Loading

Hydraulic Analysis

Infiltration and Inflow

Asset Rehabilitation and Replacement

System Resilience

Capital Improvement Program

With these goals in mind, WSC assisted the City in updating the WWSMP using the best available data for system performance and condition, both currently and as predicted within the planning horizon.

## 1.2 System Description

The City owns and operates a wastewater collection system that serves the City's residents and small portions of the surrounding communities, including the Oak Lodge Water Services District. Wastewater treatment is provided by Clackamas Water Environment Services (WES) as governed by an intergovernmental agreement with the County. Some wastewater can also be discharged into the City of Portland Lents interceptor through a metered overflow from the Brookside Pump Station

The City's collection system is composed of seven sewer basins: North Milwaukie, Mid-Milwaukie, Brookside, Johnson Creek, South Milwaukie, Harmony, and Lower Kellogg. Wastewater flow is collected at the lowest point(s) of each basin and either sent to a treatment facility or to a pump station that conveys the flow to another sewer basin. The collection system is comprised of approximately 79 miles of active gravity sewer mains and 1,710 active manholes, excluding private facilities. The gravity pipe throughout the system ranges in size from 4-inch to 27-inch diameter, with 81% of the gravity pipe being 8-inch diameter or smaller. The collection system currently includes five (5) sewage pump stations with 3,477 linear feet (LF) of force main pipelines. There is also a two-barrel inverted siphon that crosses Johnson Creek near Milwaukie Bay Park. The siphons, referred to as the Johnson Creek Siphon, includes two 12-inch diameter ductile iron pipes that are part of the City's trunk main network that allow continuous gravity conveyance from the North and Mid-Milwaukie Basins into the Kellogg WRRF.

The City does not own or maintain the lateral service lines that connect privately owned residences, commercial and industrial properties, and public facilities to the City owned sewer mains. City code requires property owners to maintain the lateral services in good working order, and ownership is delineated at the connection to the City's sewer main.

## 1.3 Agreements, Rules, and Regulations

The City maintains three intergovernmental agreements (IGAs) for the collection and treatment of wastewater with the neighboring sewer providers including WES, the City of Portland, and Oak Lodge Water Services District (Oak Lodge). Each IGA is briefly summarized below:

- Clackamas WES. The City entered into an agreement with Clackamas WES for wastewater treatment services. As part of this agreement, the City and WES acknowledged the importance of identifying and remedying RDII problems within their respective collection systems. The Kellogg Creek WRRF has limited hydraulic capacity for treatment and site constraints preclude further expansion of the facility. WES has identified that portion of the City system that flows directly into Kellogg Creek WRRF as a high priority for RDII reduction and has determined that a 65 percent reduction would optimize capital investment to meet regulatory requirements.
- City of Portland. The agreement with the City of Portland provides for direct compensation for direct connection of the City's sewer system into the Lents interceptor to serve a portion of the Johnson Creek sewer basin.
- Oak Lodge. The City and Oak Lodge provide some wastewater services for select properties within each other's jurisdictions. This agreement establishes which properties and establishes the rate of service.

The terms of the IGAs influence the analysis and recommendations for the City system, which must also meet the rules and regulations of the State of Oregon governing the operation, maintenance, and financial sustainability of municipal wastewater collection systems.

## 1.4 System Loading

Flow monitoring was conducted in the spring of 2019 and winter of 2019/2020 to understand flows under dry and wet weather conditions and to provide data for loading and calibrating the hydraulic model. The flow monitoring data was used to determine an average dry weather flow for each monitored sewer catchment. The average dry weather flow was spatially allocated within the monitored sewer catchment by using water meter locations and billing records. Wastewater generation factors were calculated based on user type (i.e., residential or non-residential) and used to estimate flow from unmonitored areas and future growth. The flow monitoring data was also used to determine diurnal curve multipliers to model how the sewer loading changes throughout the day.

Wet weather flow was estimated based on system response to flow monitoring data collected during a rainstorm on January 27, 2020, which produced the largest volume of precipitation over a 24-hour period during the flow monitoring period. The hydraulic modeling parameters were iterated for each flow monitoring basin until the estimated model response to precipitation closely resembled the flow response seen at each flow meter. These parameters were then assigned to the model for each basin to estimate the wet weather flow response under design storm conditions for a 10-year recurrence interval storm with a duration of 24 hours.

Buildout flow was estimated using a buildable lands inventory (BLI) prepared by Angelo Planning Group. The BLI identified parcels that could be developed for infill growth based on current land use zoning and policies described in the City's Comprehensive Plan. Working with the City Planning department, several assumptions were used to estimate the amount of equivalent dwelling units (EDUs) and non-residential flows that could be added through infill development of BLI parcels across the City. Based on the rate of known development applications, the City estimates that 80% of buildout will occur by the year 2040. A summary of average dry weather flow under existing, 2040, and buildout conditions is shown in Table 1-1.

**Table 1-1. Current and Future Projected Loading**

Loading Condition	2020	2040	Buildout
Average Dry Weather Flow (ADWF) (gpd)	1,621,328	2,006,855	2,135,870
Population	20,600	24,356	25,261
Residential EDU	8,729	10,320	10,704
Residential Flow (gpd)	1,003,835	1,186,800	1,230,960
Non-Residential Flow (gpd)	617,493	820,055	904,910
gpd = gallons per day Residential Flow Factor is 115 gpd per EDU Non-Residential Flow Factor is 1,529 gpd per Acre			

## 1.5 Hydraulic Analysis

The City's updated Geographic Information System (GIS) database of the wastewater collection system was used to construct a hydraulic model using SewerGEMS, Bentley's® GIS-based hydraulic modeling software. As described in the previous section, modeling parameters were adjusted to achieve predicted flows within an acceptable range of the observed flow monitoring of the system. A workshop was conducted with City staff to provide a review of the hydraulic model for existing conditions and operations staff provided some corrections based on historical observations.

Wastewater system criteria were developed for evaluating the hydraulic performance of the City's collection system based on Oregon Department of Environmental Quality (DEQ) regulations, City standards and preferences, and engineering judgement. An evaluation criteria workshop was conducted with City staff to discuss and confirm the desired level of service during dry weather and wet weather conditions. A summary of the evaluation Criteria is provided in Table 1-2.

**Table 1-2. Hydraulic Performance Criteria for Evaluation of System Capacity**

Category	Evaluation Criteria
Model Peak Wet Weather Flow (PWWF)	PWWF for purposes of evaluating system capacity will be based on the 10-year, 24-hour design storm timed to match peak RDII with daily diurnal peak dry weather flow.
Available Freeboard (>10 feet deep manholes)	Minimum 8-ft freeboard during PWWF. Freeboard measured as distance between manhole rim elevation and the maximum water surface elevation.
Allowable Surge (<= 10 feet deep manholes)	2-ft allowable surcharge during peak wet weather flow. Surge measured as the maximum water surface elevation above the outflowing pipe soffit elevation.
Pump station firm capacity	Pump station capacity is equal to, or greater than, PWWF with largest pump out of service.

A hydraulic capacity analysis was conducted using the model and consisted of dry weather and wet weather analysis. Oregon DEQ guidelines allow withholding of enforcement action for a sanitary sewer overflow occurring during a 10-year recurrence interval and 24-hour duration storm during the summer months. A rainfall hyetograph was developed based on the 10-year recurrence interval, 24-hour duration storm defined in the City's Stormwater Master Plan and was applied to the hydraulic model as the design storm to evaluate capacity during wet weather conditions.



Under existing City loading, a total of 16 manholes were identified as lacking sufficient freeboard or having excessive surcharging during the design storm. The number of deficient manholes increased to a total of 30 manholes when additional loading from projected growth was applied to the system through buildout. A total of 3 capacity related pipeline projects were identified to alleviate the hydraulic performance deficiencies, including the upgrade of approximately 1,284 linear feet of gravity sewer main within the Brookside Basin. The model also indicated the Brookside Pump Station's (S5) firm capacity was insufficient to meet peak wet weather flow, and pumping upgrades are recommended as part of condition-based replacement of equipment at the station. Due to some uncertainty regarding the accuracy of existing data, WSC recommends field surveys of existing manholes to confirm actual invert and rim elevations prior to mitigation action. Under current loading the capacity deficiencies do not appear to cause a sanitary sewer overflow and future flow monitoring to track RDII may also be used to confirm the presence of hydraulic deficiencies.

## 1.6 Rainfall Dependent Infiltration and Inflow

Clackamas WES has identified the reduction of RDII as a priority within the collection systems that convey wastewater to the Kellogg and Tri-City WRRFs, as part of an overall strategy to optimize investments in the wastewater collection and treatment system. Based on the 2019 Sanitary Sewer System Master Plan (SSSMP), Clackamas WES is requiring a 65% reduction in RDII from projected 2040 rates within the Milwaukie Basin, which consists of those sewer basins within the City that flow into the Kellogg Creek WRRF. The projected 2040 RDII rates as well as target reductions for the City basins are provided in Table 1-3.

**Table 1-3: RDII Reduction Targets Under Clackamas WES Program**

WES Basin	Projected RDII by 2040 (gpad)	RDII Target Value by 2040 (gpad)
Milwaukie	17,100	5,985
Harmony	14,100	Not applicable

The Clackamas WES SSSMP did not use flow monitoring within the collection system to adjust model outputs to approximate field observations. The SSSMP also assigned theoretical deterioration to estimate the future RDII in 2040. The City's hydraulic model was used to evaluate the existing collection system for RDII after adjusting parameters to correlate model results with observed wet weather flow monitoring data. To provide a meaningful evaluation of the City's collection system with the adjusted hydraulic model for comparison with the WES target values, the RDII was evaluated using the same November 22, 2011 storm rainfall used for identifying deficiencies in the WES SSSMP. The calibrated model results were analyzed at the locations of the permanent WES Milwaukie and Harmony meters to allow comparison with the WES target values. The resulting RDII is shown in Table 1-4.

**Table 1-4: Existing RDII**

Flow Meter	ADWF (gpd)	PWWF (gpd)	Ratio PWWF to ADWF	RDII (gpd)	Contributing Acreage <sup>1</sup>	RDII Rate (gpad)
Milwaukie	1,216,096	6,424,396	5.3	5,554,351	1,213	4,580
Harmony	863,304	2,827,751	3.3	1,969,800	556	3,542
1. The contributing acreage represents a buffer area within 100 feet of each sewer main.						

The total RDII rates for the Milwaukie and Harmony meters are below the WES RDII Reduction Program targets for 2040. Although there does not appear to be the need for implanting RDII reduction efforts at this time, continued structural condition repairs described in the next section will be required to maintain the current RDII rate. The Brookside, North and South Milwaukie basins appear to be a higher priority for continued structural condition repairs to maintain RDII rates at the Milwaukie Meter below the 2040 target.

. WSC recommends flow monitoring at 5-year intervals to track changes in the RDII rate over time so that the observed values are maintained below the WES 2040 target.

## 1.7 Asset Rehabilitation and Replacement

The City understands the importance of proactively rehabilitating and replacing aging assets to maintain a safe and reliable wastewater collection system for its customers. Assets are divided into two categories: gravity pipelines that are capable of closed-circuit television (CCTV) inspection and pump stations, including the force main pipelines.

The City maintains a dedicated crew that performs cleaning and a CCTV inspection of each sewer main in the collection system on a four-year cycle. During each CCTV inspection, sewer mains are coded according to the National Association of Sewer Service Companies' Pipeline Assessment Certification Program (PACP) to provide defect scoring for each main on a 1 to 5 scale, with a score of 5 representing the worst defects, or those that present an imminent risk of structural failure. At the time of this WWSMP, the City has PACP scores available for 55 percent of mains and is expected to have data on all mains within the next two years. Condition projects were identified for pipelines having Grade 5 or Grade 4 defects which are anticipated to result in structural failure within the next 10 years. An annual rehabilitation budget was established to address these mains with Grade 5 and Grade 4 defects, assuming a similar ratio of high-priority defects within the portion of the City system that remains to be inspected and scored. A system for ranking and prioritizing sewer pipe rehabilitation projects based on risk of failure, defined by evaluating the consequences of a failure and the probability based on the existing condition, is recommended. Each year, the City should use the PACP scores and consequence of failure data to prioritize the highest risk mains in need of rehabilitation or replacement so that the rehabilitation budget is consistently used for mitigating the highest risk sewer pipelines based on the best information available.

The condition of pump stations and their various components are not currently assessed or tracked by the City. Operators indicated that there are not currently any known condition deficiencies at the pump stations that require immediate attention, but given the age of the stations and equipment, some of the critical components will likely reach the end of their useful life within the 20-year planning period of this WWSMP. Based on original record drawings and pump data sheets provided by the City, the components of each pump station expected to reach the end of their remaining useful life were identified and the costs for replacing those components was estimated using a parametric cost database. An estimated total cost of \$4.25M would be required for a program to replace aging components within the City's pump stations, which if executed over a 10-year period would require an average of \$425,000 in CIP projects each year. To better understand the timing of repairs, and to confirm the scope of replacements, WSC recommends a pump station condition assessment be completed for each of the City's stations within the next biennial budget cycle. Additional condition-based projects identified by the City outside of this WWSMP and previously included within the current 2021 to 2026 budget are also included.

## 1.8 System Resilience

In accordance with the Oregon Resilience Plan, the City is looking to reduce risk and improve recovery of the collection system associated with a Cascadia Subduction Zone (CSZ) magnitude 9.0 earthquake. SEFT led a workshop with City staff to identify and document level of service goals for restoring wastewater service following a CSZ earthquake. A sewer backbone was identified consisting of large trunk mains, the siphons, lift stations and pipes serving facilities that connect to critical facilities, such as hospitals, the City's well sites, and schools, with the goal of returning service to this backbone as quickly as possible following the earthquake. Seismic assessments of several critical pump stations were also conducted to identify and recommend retrofits to the backbone system.

Seismic hazard mapping was conducted by McMillen Jacobs Associates to estimate the peak ground velocity and peak ground deformation (PGD) within the City's service resulting from a CSZ seismic event. A pipe fragility analysis was conducted to estimate the repair rates for each pipeline based on assumed pipe materials and estimated PGD. Pipes were then categorized in terms of the priority for seismic retrofits.

Recommendations were provided for both updates to the City Design Standards and for capital improvements. City Design Standards should be updated to require more robust piping for high and medium seismic risk pipes, such as fused high-density polyethylene, ductile iron pipe with seismic joints, or PVC pipe. The appropriate pipe material will depend on engineering analysis of the anticipated PGD within the area of each pipe. As high-priority backbone pipes reach the end of their useful life, they will be replaced or repaired with the appropriate materials for seismic resiliency. Recommended improvements include upgrading existing backbone pipes with Grade 5 or Grade 4 defects to meet these standards, retrofitting the Home and Monroe (S3) and Brookside (S5) pump stations to meet current seismic code, and fully rebuilding the Island Station (S1) pump station to meet current seismic code. The costs for these improvements would be included within the annual budget for pipe and pump station rehabilitation and replacement.

In accordance with the City's Climate Action Plan, the collection system was also evaluated for potential risk of climate impacts. A sea level rise analysis was conducted if sewer collection system facilities might be impacted by the tidally influenced Willamette River and the City's design standards were reviewed to determine if revisions to sewer standards were needed to reduce climate impacts. Climate Central's Coastal Risk Screening Tool was used to approximate the possible extents of flooding caused by sea level rise and found that manhole rims for trunk sewers within Milwaukie Bay Park and the inverted siphon crossing beneath Johnson Creek may be below future floodwater elevations, posing the risk of massive amounts of inflow that could overwhelm the system. To mitigate this issue, it is recommended the frame and cover of these manholes be replaced with bolt-down watertight assemblies.

## 1.9 Capital Improvement Program

Projects identified to address capacity deficiencies, condition-based rehabilitation and replacement projects, and seismic risk mitigations are scheduled as part of a recommended CIP. Cost estimates were developed for individual projects in conformance with the Class 5 Conceptual Report Classification of Opinion of Probable Construction Costs as developed by the Association for the Advancement of Cost Engineering. Projects were scheduled and prioritized based on District input, anticipated end of useful life, coordination with the City's Safe Access For Everyone program projects, and other prioritization criteria. A summary of the recommend capital improvement projects, including the opinion of probable construction costs, is provided in Table 1-5.

To implement the CIP, the City will need to spend approximately \$1.3M on average each year to fund capital improvement projects, with an average annual spend of \$1.6M per year during the first 10 years. The proposed level of spending does not represent a dramatic increase from the current levels of spending within the City's wastewater fund, so a dramatic increase in wastewater rates is not anticipated to be necessary to fund the recommended improvements. The City prepares budgets on a biennial basis with the next budget cycle occurring in 2023.

Opinions of probable construction costs for all eligible capacity increasing costs were used to calculate a recommendation for an updated system development charge (SDC) of \$1,065 per EDU. The calculated SDC is slightly lower than the current City wastewater SDC of \$1,269 per EDU. FCS Group has also provided a schedule for scaling the SDC based on the square footage of and type of single-family dwelling unit structures, similar to a schedule that is currently under consideration by Clackamas WES for the wastewater treatment SDC.

Table 1-5. Capital Improvement Program Summary

Project ID	Description	Pipe Length (feet)	Diameter (Inches)	Project Total (2021 Dollars)
<b>Capacity (CAP) Projects</b>				<b>\$1,423,000</b>
CAP-1	Manhole Surveying	-	-	\$475,000
CAP-2	Pipe Upgrades	1,284	10	\$819,000
CAP-3	Flow Monitoring (Every 5 Years)	-	-	\$124,000
CAP-4	Harvey Street Improvements	-	-	\$5,000
<b>Condition (C) Projects</b>				<b>\$23,404,000</b>
C-1	Pipeline Rehabilitation and Replacement	Varies	Varies	\$11,928,000
C-2	Pump Station Condition Assessments	-	-	\$30,000
C-3 thru C-7	Pump Station Improvements	-	-	\$3,408,000
C-8	Johnson Creek Siphon Inspection	1,368	12	\$100,000
C-9	Waverly Heights Sewer System Reconfiguration	3,206	8	\$3,404,000
C-10	Waverly South	220	10	\$91,000
C-11	SCADA Design and Construction	-	-	\$105,000
C-12	Ardenwald North Improvements	1,542	8	\$476,000
C-13	Milwaukie/El Puente SRTS Improvements	776	10	\$522,000
C-14	Logus Road & 40 <sup>th</sup> Ave Improvements	403	6 & 8	\$149,000
C-15	Wastewater System Improvements FY2023	1,535	8	\$491,000
C-16	International Way Improvements	354	12	\$144,000
C-17	North Milwaukie Improvements	1,955	6 & 8	\$465,000
C-18	SAFE & SSMP FY2025 Improvements – Park/Lloyd/Stanley	401	8	\$139,000
C-19	Vehicle Purchases	-	-	\$752,000
C-20	Lift Station Pump & SCADA Controls Replacement	-	-	\$200,000
C-21	Wastewater Capital Maintenance Program	-	-	\$1,000,000
<b>Resilience (R) Projects</b>				<b>\$13,000</b>
R-1	S1 Island Pump Station Rebuild	-	-	Included in C-3 thru C-7
R-2	S3 Home & Monroe Pump Station Retrofit	-	-	Included in C-3 thru C-7
R-3	S5 Brookside Pump Station Retrofit and Pump Upgrade	-	-	Included in C-3 thru C-7
R-4	Bolted Manholes	-	-	\$13,000
<b>Planning (P) Projects</b>				<b>\$800,000</b>
P-1	Wastewater System Master Plan Update (Every 5 Years)	-	-	\$800,000
<b>CIP Total</b>				<b>\$25,640,000</b>

Notes: Project costs rounded up to nearest \$1,000 and based on ENR 20-City Average CCI of 11989.91 for May 2021.

## CHAPTER 2

# Introduction

The City of Milwaukie (City) provides wastewater collection services to City residents as well as a few residents from the Oak Grove areas of unincorporated Clackamas County. This Wastewater System Master Plan (WWSMP) Update guides planned capital project expenditures and asset management for its wastewater collection system in an efficient and cost-effective manner.

## 2.1 Objectives

The City contracted with Water Systems Consulting, Inc. (WSC) to develop a WWSMP to guide the planning of capital project expenditures through a planning horizon of 2040. The WWSMP provided herein serves as an update to the previous version that was prepared in 2010.

During the process of preparing the updated WWSMP, the City identified the following objectives:

- Plan for growth expected within the City’s existing service area based on proposed modifications to planning policy that allow for increased residential density
- Plan for expansion of the City’s service area to accommodate development within the Urban Growth Management Area (UGMA)
- Develop an accurate hydraulic model of the collection system
- Identify the level of rainfall dependent infiltration and inflow (RDII) within the collection system
- Understand capacity limitations at the Kellogg Creek Water Resource Recovery Facility (WRRF)
- Identify existing and future system capacity and condition deficiencies
- Assess the City’s vulnerability to seismic events and climate change and identify potential mitigation measures to improve system resilience
- Alignment of the wastewater system plan with parallel City initiatives to take action against climate change and to improve housing affordability
- Develop a prioritized list of improvement projects, including anticipated costs, to address the deficiencies and assure capacity of the collection system

---

### IN THIS SECTION

Objectives

Authorization

Relationship to Other Documents and City Programs

City Overview

---

## 2.2 Authorization

The City has contracted with WSC as described in the Engineering Services Agreement with the City for the WWSMP, executed on April 19, 2019. WSC has partnered with SFE Global to provide flow monitoring services, McMillen Jacobs Associates and SEFT Consulting Group to assist in preparing a seismic risk assessment and mitigation plan, and the FCS Group to assist in developing system development charges (SDCs) for the 20-year planning period.

## 2.3 Relationship to Other Documents and City Programs

The WWSMP will serve as a key piece of the City's long-range planning process and ongoing operations of their collection system, but also incorporates recommendations and considers the objectives of other planning efforts that have some overlap with the sewer collection system. A partial list of related documents is included here, and a supplemental list of references is included in Chapter 11 -References.

**1994 Sewerage Facilities Plan (1994 SFP)** – The City's first comprehensive sewage facilities plan was prepared by CH2M Hill to evaluate their collection system through 2010 (1). The 1994 SFP provided information on how the City's sewer basins have changed and expanded over the past two decades, including the approximate years of sewer system installation throughout the City.

**2010 Wastewater Master Plan (2010 WWSMP)** – The City's most recent WWSMP was prepared by Parametrix in 2010 and evaluated the City's system through 2030. The 2010 WWSMP was used as a reference document for the City's existing system.

**Sanitary Sewer System Master Plan for Water Environment Services (WES 2019 SSSMP)** – Clackamas Water Environment Services (WES) recently completed an update to their sanitary sewer system master plan (SSSMP). WES owns and operates the Kellogg Creek WRRF, where the majority of the City's wastewater is treated. WES also owns and operates the Tri-City WRRF and a network of pump stations and conveyance pipelines that divert and treat peak wet weather flows in excess of the treatment capacity at the Kellogg Creek WRRF. The WES 2019 SSSMP concluded that the most cost-effective method for providing future wastewater treatment capacity is to require member agencies to achieve a 65-percent reduction in the volume of RDII in the collection system by the year 2040. (2) As a contributor to the Kellogg Creek WRRF, the City's collection system will be required to reduce RDII in accordance with the recommendations.

**2018 Climate Action Plan (Climate Action Plan)** – In October 2018, the City adopted their first Climate Action Plan to take aggressive steps to minimize climate change and increase climate related resilience within the City. The plan creates a framework to support the City's vision of having net zero emissions for electricity by the year 2030, achieving buildings with no net emissions by the year 2035, and becoming a fully carbon neutral city by the year 2045. (3) The plan identifies a variety of mitigation and adaptation strategies for the City to implement to achieve these goals. In line with the Climate Action Plan, this WWSMP incorporates utility resilience and hazard mapping with consideration to climate change.



**Comprehensive Plan Policy Document** – The City adopted a new Comprehensive Plan Policy Document on August 18, 2020, updating the previous version which was adopted in 1989. As part of this effort, the City identified strategies to provide long-term housing demand and affordability, and updated policies to allow increased densification in mixed-use residential areas that promote walkable neighborhoods. Policy changes may affect the geospatial distribution and volume of future sewer loading and must be considered for future capital improvements to the wastewater system. The future impacts on the wastewater system will be summarized into the Wastewater Element of the City’s Public Facilities Plan, which will be incorporated into the Comprehensive Plan.

**SAFE Program** – The City’s Safe Access for Everyone (SAFE) program is an ongoing effort to improve safety for those walking, biking, and using alternative modes of transportation within the City. The SAFE program includes a mix of projects for upgrading the City’s network of connections, which include installing new sidewalks, ramps and crossings to fill network gaps, replacing portions to improve compliance with the Americans with Disabilities Act (ADA), and removing barriers for people to help them get where they need to go safely. The SAFE program is funded by a mix of grants, the SAFE fee, and urban renewal. Projects identified within this WWSMP will be coordinated with scheduled SAFE Program projects to minimize disruption to the surrounding community.

## 2.4 City Overview

The following section summarizes the City’s location, topography, climate, population, land use, and service area.

### 2.4.1 Location

The City is primarily located within northwestern Clackamas County with a small portion in southwestern Multnomah County. The City is bordered by the City of Portland to the north, the Willamette River to the west, Kellogg Creek to the south, and unincorporated Clackamas County to the east as shown in Figure 2-1.

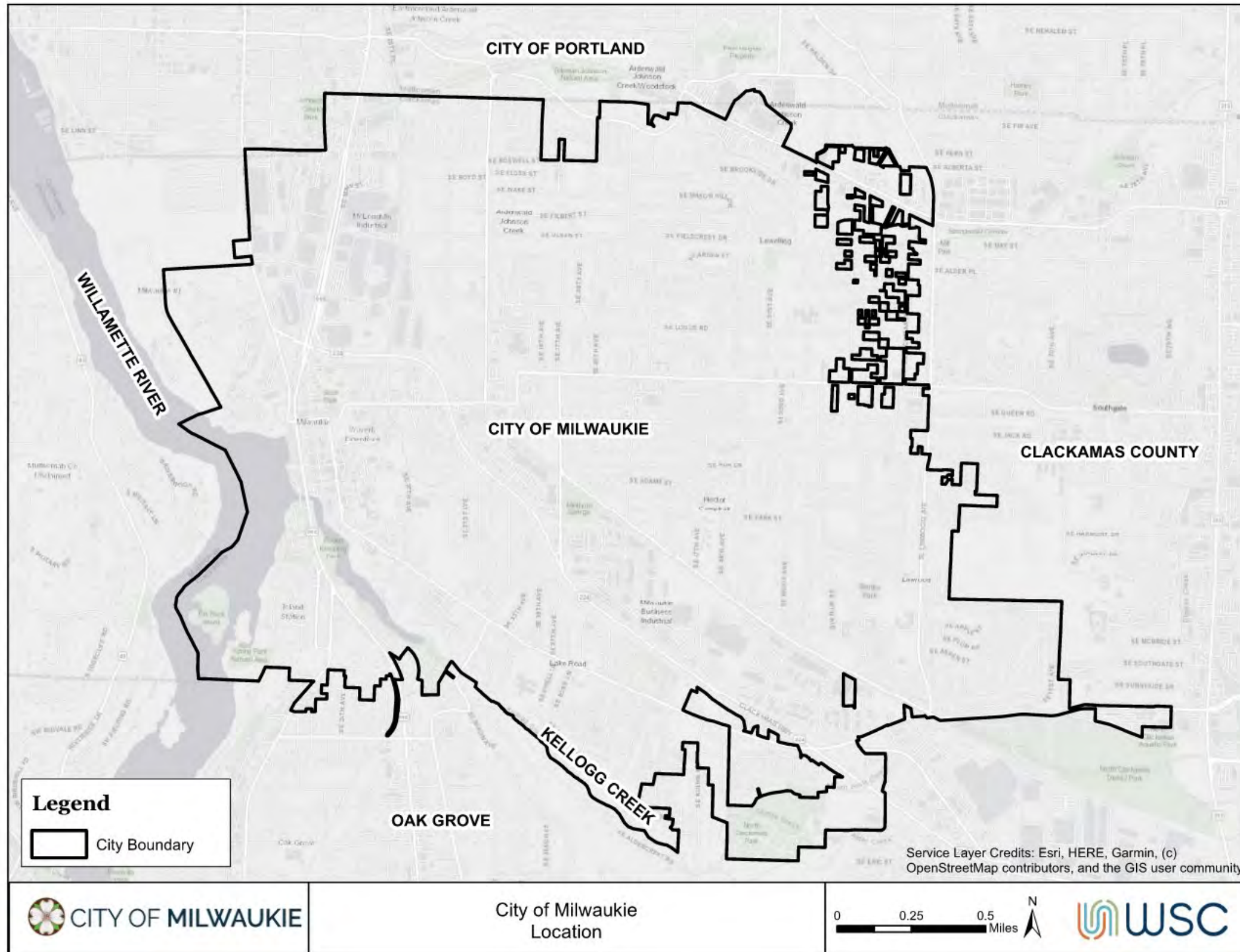


Figure 2-1: Location Map

## 2.4.2 Topography

The City's sewer system mimics the natural drainage within the City, which generally follows the drainage pattern of Johnson Creek and Kellogg Creek from east to west towards the Willamette River. Elevations within the City range from approximately 10 feet (ft) above mean sea level (msl) to approximately 200 ft above msl. (4) Ground surface slopes are generally moderate within the City's sewer basins. Surface water within the region consists of Mount Scott Creek, Kellogg Creek, Johnson Creek, Spring Creek, and Kellogg Lake. Mount Scott Creek flows into Kellogg Creek, which ultimately flows into the Willamette River. Spring Creek is a small stream located in the western portion of the City that discharges into Johnson Creek. Johnson Creek flows through the northwestern portion of the City and empties into the Willamette River. (1)

## 2.4.3 Climate

The City lies within the temperate Mediterranean climate under the Köppen Climate Classification System. (5) Precipitation is common year-round with the heaviest precipitation between October and April. December is typically the wettest month of the year. Average and record climate characteristics are provided in Table 2-1.

**Table 2-1: Climate Data for Milwaukie, OR (6)**

Parameter	Value
Record High Temperature	106°F
Average Annual High Temperature	62.5°F
Average Annual Low Temperature	46.4°F
Record Low Temperature	8°F
Average Annual Rainfall	43.01 in.

## 2.4.4 Population

The City's estimated current population is 20,990 people as of 2019. (7)

## 2.4.5 Land Use

The City is primarily zoned for residential land use. Top industries by number of employees include government, healthcare, professional, scientific and technical services; education; and metal manufacturing. (8)

## CHAPTER 3

# Existing Wastewater System

This chapter describes the City’s existing wastewater collection system including the service area boundary, the basins within the collection system, the inventory of assets, the current operations and maintenance program, data systems, and adjacent or partner sewer agencies.

## 3.1 Existing Service Area

The City owns and operates a wastewater collection system that serves the City’s residents and small portions of the surrounding communities. The City’s collection system connects to the City of Portland’s and Clackamas WES’ collection systems. Wastewater treatment is provided by Clackamas WES. Milwaukie’s current wastewater service area is shown in Figure 3-1.

### 3.1.1 Wastewater Treatment

The City contracts with Clackamas WES to provide wastewater treatment for all of their collection system, with the exception of the Johnson Creek basin at the northeast extents of the service area, which drains to the City of Portland’s Lents Trunk sewer. Wastewater collected in the North Milwaukie, Mid Milwaukie, South Milwaukie, Lower Kellogg, Harmony, and Brookside basins is directed to Clackamas WES’ Kellogg Creek WRRF for treatment. When Kellogg Creek WRRF’s capacity is reached, such as during a wet weather event, Clackamas WES can divert wastewater from the eastern half of the City to the Tri-City WRRF for treatment via the Intertie Two Pump Station. The Kellogg Creek WRRF is currently undergoing expansion efforts to provide additional capacity, but the facility is limited by its footprint. Upon completion of the upgrades (anticipated for completion in 2022), the plant is anticipated to have a dry weather capacity of 10 million gallons per day (MGD) and a wet weather capacity of 25 MGD.

---

#### IN THIS SECTION

Existing Service Area

Sewer Basins

System Inventory

System Loading

Maintenance Activities  
and ProgramsData Systems and  
Information  
Management



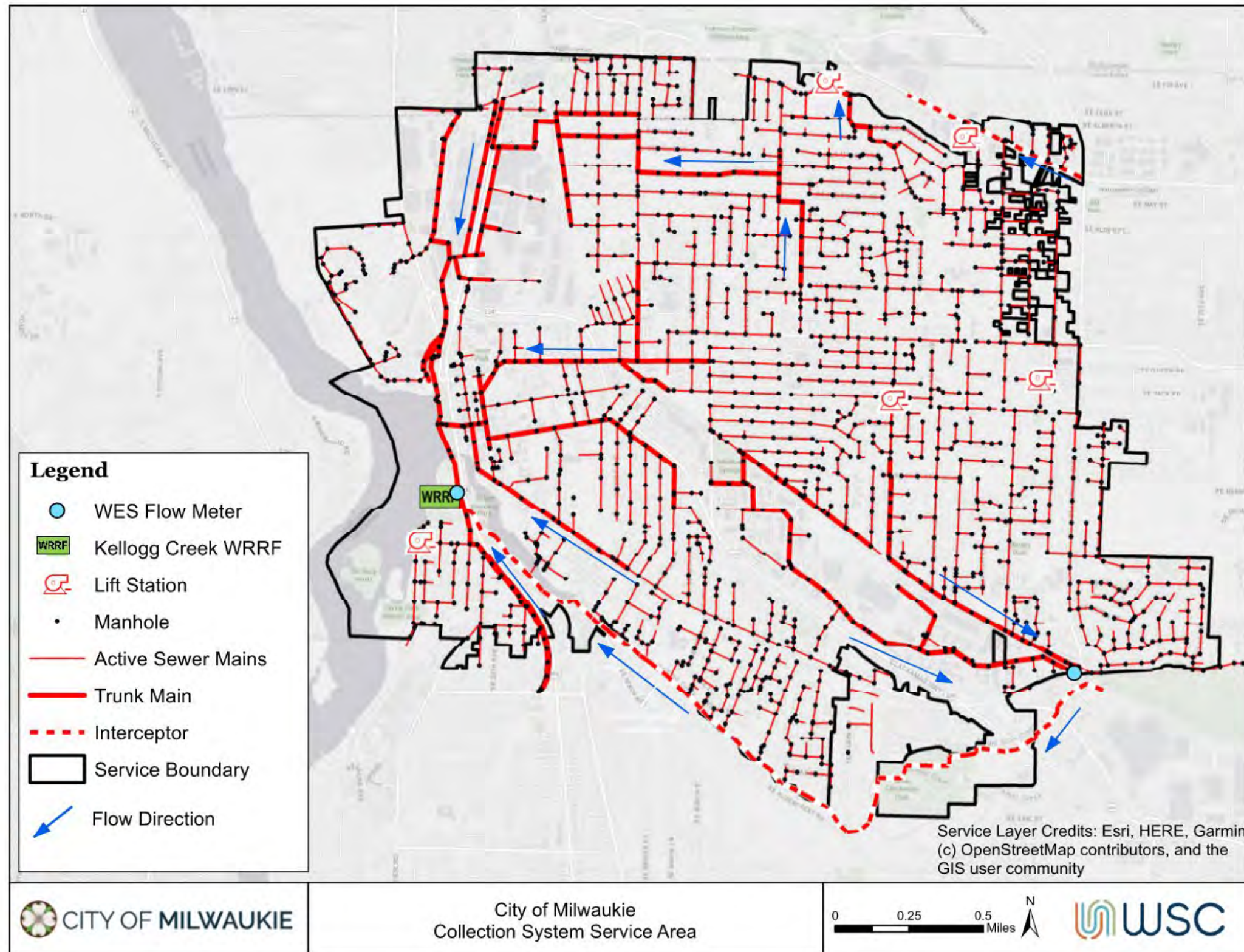


Figure 3-1 – City of Milwaukie Service Area

## 3.2 Sewer Basins

The City's collection system is divided into seven sewer basins, primarily defined by topography. The basins, as shown in Figure 3-2, are:

- North Milwaukie;
- Mid-Milwaukie;
- Brookside;
- Johnson Creek;
- South Milwaukie;
- Harmony; and
- Lower Kellogg

Additional information on each sewer basin is provided in the subsections below. A small portion of the City's collection system is treated by the City of Portland and Oak Lodge Water Services District (Oak Lodge). Flow within the Johnson Creek basin is pumped directly into the City of Portland's Lents Interceptor, where it is conveyed to the City of Portland's Columbia Boulevard Wastewater Treatment Plant. A portion of the South Milwaukie Basin (seven City customers) directly connects to Oak Lodge's system, where it is conveyed to the Oak Lodge Water Reclamation Facility. Information on the agreements in place with these entities is provided in Section 4.1.

### 3.2.1 North Milwaukie Basin

The North Milwaukie Basin serves a majority of the northern portion of the City, extending from the Willamette River on the west up to Johnson Creek Boulevard on the north, as shown in Figure 3-2, and consists of approximately 21 miles of pipe. The basin covers approximately 900 acres and serves a mix of single family residential, multifamily residential, commercial, and industrial users. (9) Sewage generated within the basin is conveyed to the Kellogg Creek WRRF via trunk lines ranging in size from 12-inches to 24-inches in diameter.

### 3.2.2 Mid Milwaukie Basin

The Mid Milwaukie Basin serves the central portion of the City, extending south of Howe Street on the north, west of SE McLoughlin Boulevard, east of SE 42<sup>nd</sup> Avenue, and north of Lake Road, as shown in Figure 3-2, and consists of approximately 17 miles of pipe. The basin covers approximately 615 acres and serves the town center and a mix of public land and low, moderate, and high-density residential housing. (9) Sewage generated within the basin is conveyed to the Kellogg Creek WRRF via three main trunk lines ranging in size from 8-inches to 24 -inches in diameter. The trunk mains combine with the flow from the North Milwaukie Basin, which then passes through WES' Milwaukie Flow Meter on its way to the Kellogg Creek WRRF. The basin consists of residential, downtown, and commercial/mixed use customers. Most of the City's commercial/mixed-use zoning lies within this basin. Notable customers include Providence Hospital, Clackamas Fire District Station 2, Milwaukie Police Department, and most of the City's schools.



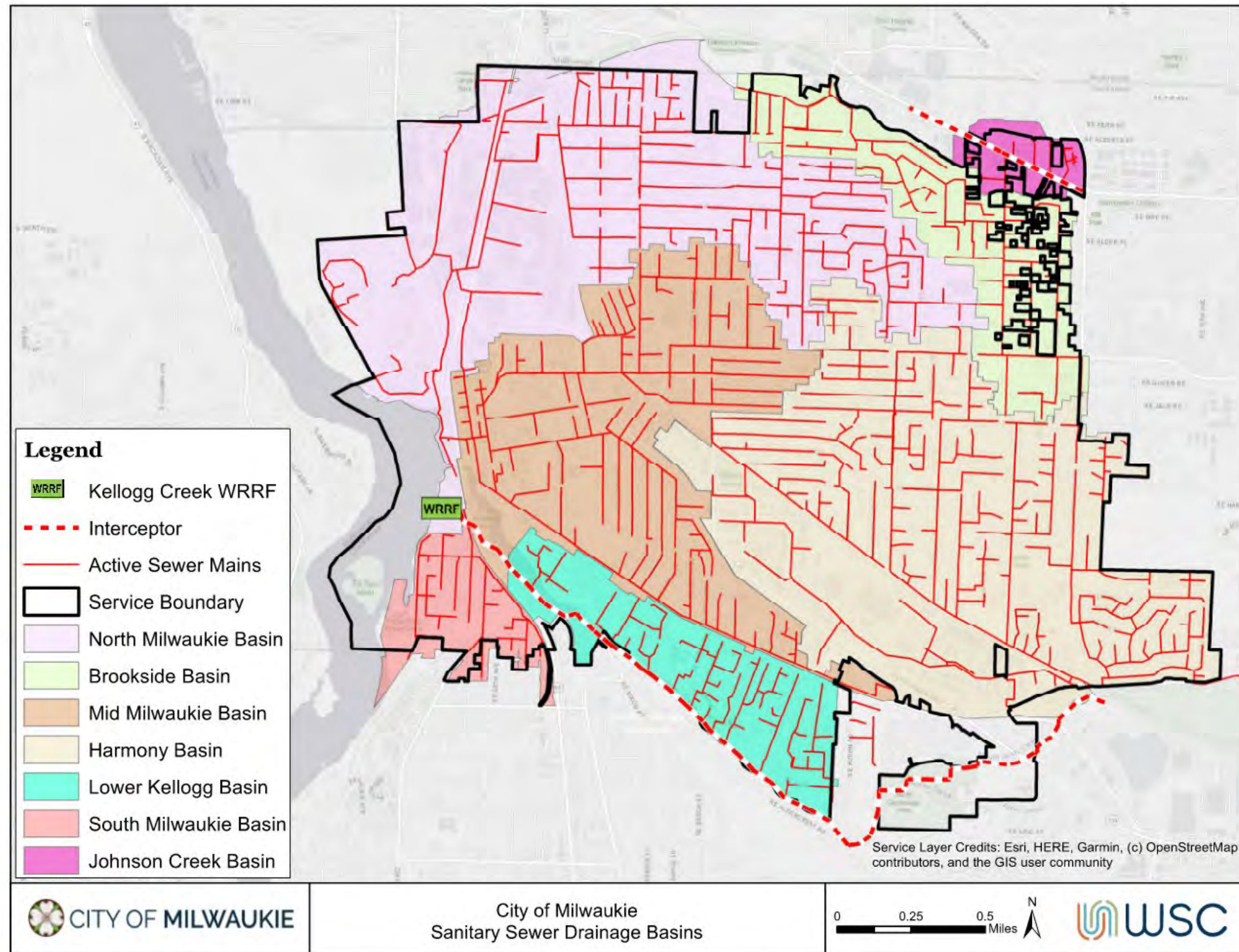


Figure 3-2: Collection System Sewer Basins

### 3.2.3 South Milwaukie Basin

The South Milwaukie Basin serves the southwest portion of the City, extending south of the Kellogg Creek WRRF and west of SE McLoughlin Boulevard to the City's southern city limit and consists of approximately 4 miles of pipe. The basin covers approximately 115 acres and serves primarily residential customers and a small commercial zone. (9) This basin collects wastewater from 30 customers that lie within the Oak Lodge service area, represented by the South Milwaukie Basin area that lies outside of the service boundary shown in Figure 3-3. Flow within this basin is transported to the Kellogg Creek WRRF via a trunk line (8-inch to 12-inch diameter) that connects to the main interceptor upstream of WES' Milwaukie Meter. Seven of the City's residents that border Oak Lodge's service area boundary near this basin send their wastewater to Oak Lodge instead of to the City's collection system due to topography, where it is treated at the Oak Lodge Water Reclamation Facility (Figure 3-3).

The South Milwaukie Basin contains the Island Station Pump Station (S1), located at the intersection of SE Bluebird Street and SE 19<sup>th</sup> Avenue adjacent to the Willamette River. The station pumps the sewage from the lift station to the eastern downstream manhole via an 8" ductile iron force main. The sewage is then conveyed by gravity to the basin's trunk line. Additional information on Pump Station S1 is found in Section 3.3.2.

### 3.2.4 Harmony Basin

The Harmony Basin serves the southeastern portion of the City. The basin consists of approximately 25-miles of pipe and covers approximately 980 acres serving single-family and multi-family residential customers, a small portion of commercial customers, and the majority of the City's industrial customers. (9) Flow is conveyed through two primary trunk lines. The first trunk line (12-inch to 15-inch diameter) runs along SE Railroad Avenue and SE Home Avenue capturing flows from the residential customers. The second trunk line (15-inch to 18-inch diameter) runs along SE International Way to capture flows from the industrial and commercial customers. The two trunk lines combine near the intersection of SE Harmony Road and SE Railroad Avenue, where the flow is metered by WES' Harmony Meter as it enters WES' Mount Scott Interceptor. The flow is then directed to WES' Lower Kellogg Interceptor, which carries the flow to the Kellogg Creek WRRF for treatment.

The Harmony Basin contains two of the City's five sewage pump stations. The Home and Monroe Pump Station (S3) is located near the intersection of SE Home Avenue and SE Monroe Avenue. The sewage pump station serves residential and commercial customers across an area of approximately 123 acres. The service area of this pump station was identified as the King Road Basin in the 1994 SFP. (10) The Harrison Pump Station (S2) serves three homes containing basements near the intersection of SE Harrison Street and SE 59<sup>th</sup> Avenue. Additional information on these sewage pump stations is provided in Section 3.3.2.



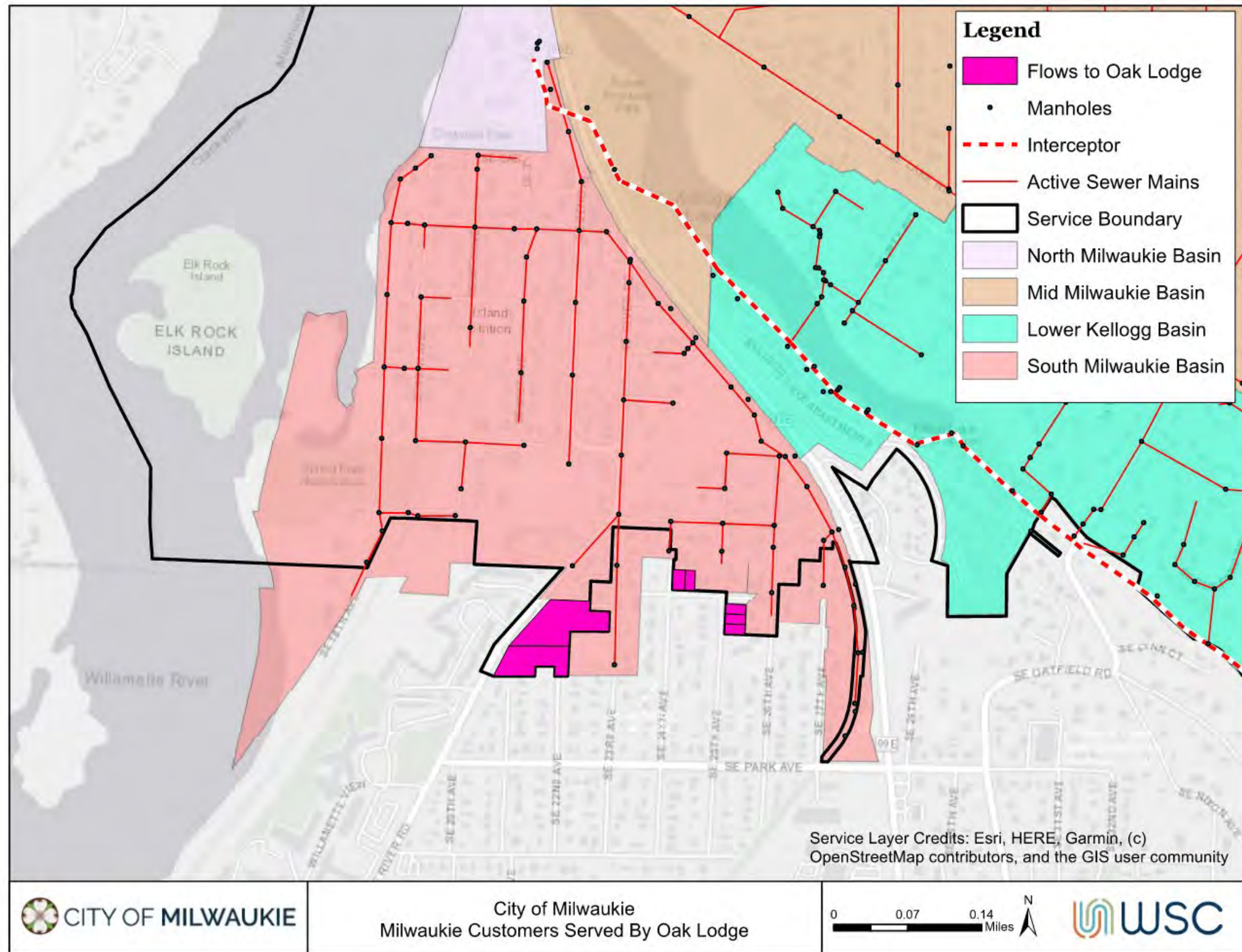


Figure 3-3: Customers Served by Oak Lodge Water Services

### 3.2.5 Brookside Basin

The Brookside Basin serves a portion of the City's northeastern service area and consists of approximately 8 miles of pipe. The basin covers approximately 288 acres of single and multi-family residential customers. (9) The Brookside Pump Station (S5) is located within the basin near the intersection of SE Brookside Drive and SE Johnson Creek Boulevard. The sewage pump station pumps sewage to the gravity sewer on SE Filbert Street, where it connects with the trunk line serving the North Milwaukie Basin. The Brookside Pump Station contains an overflow relief line that directs flow to the City of Portland's Lents Interceptor in the event of station failure to prevent raw sewage from overflowing into Johnson Creek. Additional information on Pump Station S5 is provided in Section 3.3.2.

### 3.2.6 Johnson Creek Basin

The SE Johnson Creek Basin serves the northeastern portion of the City's service area and consists of approximately 2 miles of pipe. The basin covers approximately 58 acres north of Johnson Creek Boulevard between SE Stanley Avenue and SE Linwood Avenue and serves residential and industrial customers. (9) Notable customers include the City of Milwaukie Public Works building. The basin's sewage is collected in the 55<sup>th</sup> Avenue Pump Station (S6) located at 55<sup>th</sup> Avenue and Johnson Creek and is pumped into the City of Portland's Lents Interceptor. Additional information on Pump Station S6 is provided in Section 3.3.2. For billing purposes, the City collects sewer bills for customers in the Johnson Creek basin and forwards them to the City of Portland on a monthly basis.

### 3.2.7 Lower Kellogg Basin

The Lower Kellogg Basin serves a portion of the City's southern service area and consists of approximately 5 miles of pipe. The basin covers approximately 230 acres and serves primarily residential customers. Rowe Junior High School is among these customers. Service is provided to these customers through lateral sewers that directly connect to WES' Lower Kellogg Interceptor at nine locations, which then transports flow to the Kellogg Creek WRRF for treatment.

## 3.3 System Inventory

### 3.3.1 Gravity Pipelines and Manholes

Based on the Geographic Information System (GIS) data provided, the City's existing wastewater collection system is comprised of approximately 79 miles of active gravity sewer mains and 1,710 active manholes, excluding private facilities. The gravity pipe throughout the system ranges in size from 4-inch to 27-inch diameter, with 81% of the gravity pipe being 8-inches or smaller. All pipes in GIS with unknown diameter

were assumed to be 8-inch or smaller. The distribution of pipe length by diameter is shown in

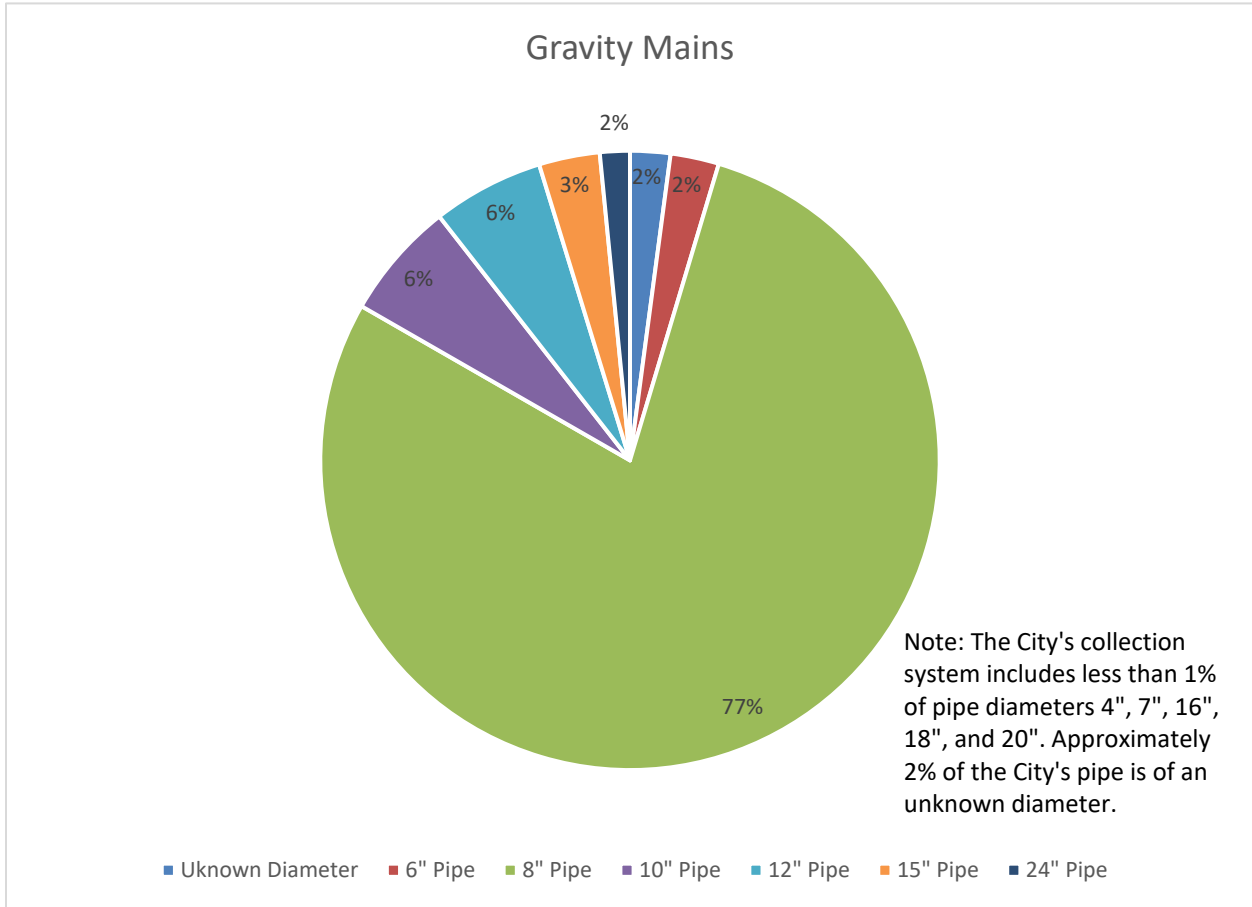


Figure 3-4.

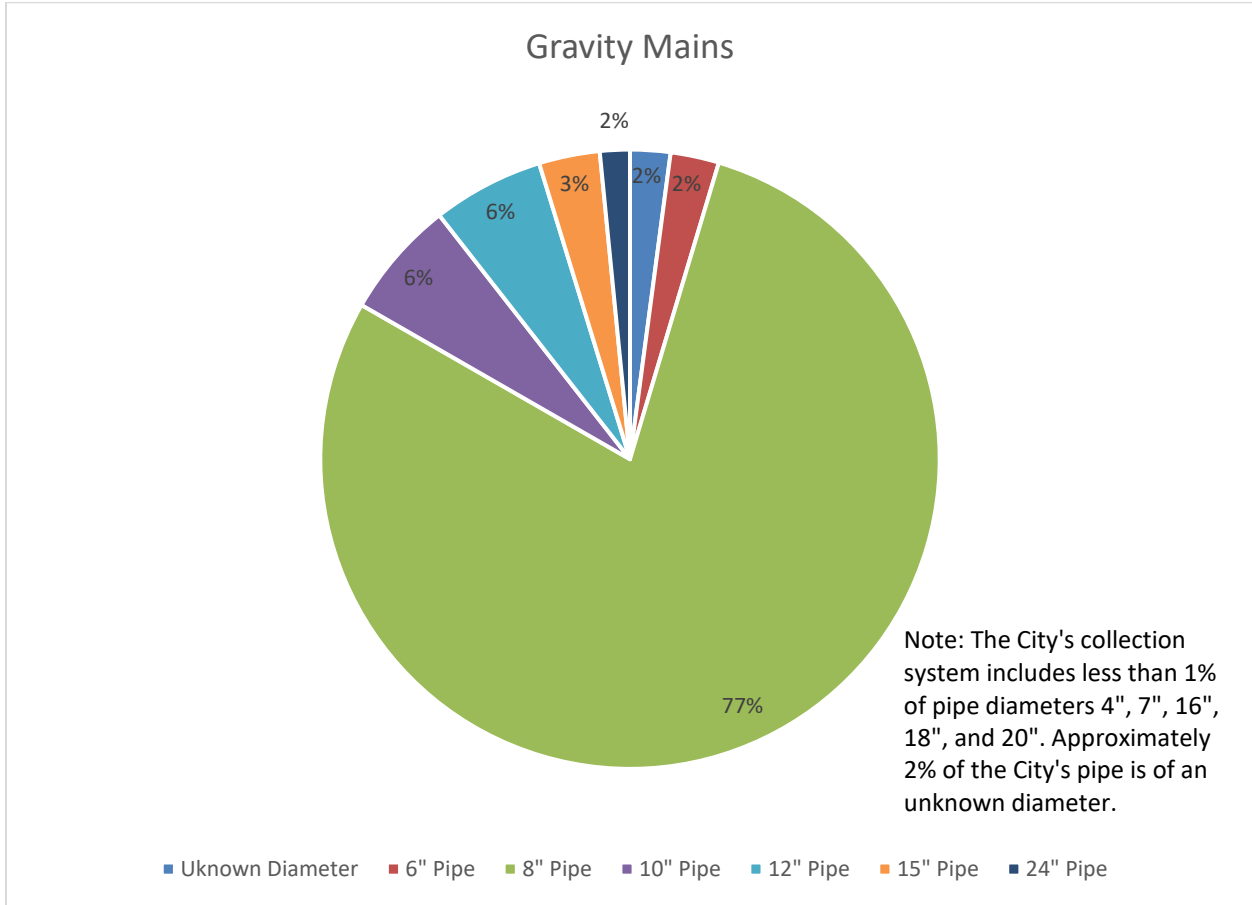


Figure 3-4: Gravity Pipe Length by Diameter in Inches

### 3.3.2 Sewage Pump Stations and Force Mains

Based on the GIS data provided, the City’s collection system currently includes five (5) sewage pump stations and 3,477 linear feet (LF) of force main. Table 3-1 provides a summary of several operational parameters with respect to individual pump stations.

Table 3-1: Lift Station Summary Table

Sewage Pump Station	No. of Pumps	Firm Capacity with Largest Pump Out of Service (gpm)	Horsepower per Pump (hp)	Station Type
Island Pump Station (S1)	2	215	5	Suction Head
Harrison Pump Station (S2)	2	100	7.5	Submersible
Home and Monroe Pump Station (S3)	2	400	25	Dry Pit/Wet Pit
Brookside Pump Station (S5)	2	550	75	Suction Head
55 <sup>th</sup> Avenue Pump Station (S6)	2	159	5	Submersible

gpm = gallons per minute      hp = horsepower

### 3.3.3 Inverted Siphons

The City's sewer collection system contains a two-barrel inverted siphon that crosses Johnson Creek near Milwaukie Bay Park. The siphon, referred to as the Johnson Creek Siphon, consists of two 12" diameter ductile iron pipes that are part of the City's trunk main network that allow for continuous gravity conveyance from the North Milwaukie Basin into the Kellogg Creek WRRF. This siphon was identified as requiring future work in the 2010 WWSMP. Regular maintenance of these siphons is necessary to prevent debris from impeding flow through the siphon and causing a backup in the collection system.

## 3.4 Maintenance Activities and Programs

The City's collection system preventative maintenance programs include routine cleaning, root control, closed-circuit television (CCTV) inspections, and sewage pump station maintenance. The operations staff regularly conducts CCTV of their entire system on a four-year cycle (approximately 25% of the system is inspected each year). Several "high maintenance" sewer segments, as shown in Figure 3-5, are cleaned on a more frequent quarterly schedule due to a history of fats, oils, and grease accumulation or root intrusion.

## 3.5 Data Systems and Information Management

The City maintains two primary data systems, GraniteNet and Cityworks, to organize and analyze physical attributes, maintenance requirements and condition assessment observations associated with the wastewater collection system. Cityworks is the City's primary wastewater asset management system, operated by the collection system staff and maintained by the City's asset management technician. Cityworks is a GIS based system that allows the City to maintain information about each asset, including attributes, descriptions, and maintenance history. Any changes made within Cityworks automatically syncs with the City's GIS databases, allowing collection system staff to provide real time updates in the field. Cityworks is also used to schedule and generate work orders for the collection system staff to ensure issues are addressed in a timely matter.

GraniteNet is the City's pipeline inspection software. The software is compatible with the National Association of Sewer Service Companies' (NASSCO) Pipeline Assessment Certification Program (PACP). The City uses this software to store CCTV videos for all their mains and their associated PACP scores. GraniteNet is linked to Cityworks to allow for cleaning and inspection work orders.

The City is in the process of adding GranitePortal to their GraniteNet license. This will allow the asset management team to grant access to others, both inside and outside of the City, to view inspection related data in a read-only format. This is expected to allow the City to easily share their pipe inspection data while protecting the integrity of the data.

The City operates and maintains a supervisory control and data acquisition (SCADA) system for the collection system. The SCADA system tracks run time and alarm conditions for each of the City's five sewage pump stations. Flow monitoring within the City's collection system is conducted by Clackamas WES at two permanently installed flow meters (Milwaukie Meter near the Kellogg Creek WRRF and the Harmony Meter near the intersection of SE Railroad Avenue and SE Harmony Road) that measure flow rates, velocities, and water depth. The Clackamas WES flow meters document the flow rate and total volume of wastewater received from the City into WES' system for conveyance and treatment. The City does not own or operate any permanent flow meters within the collection system.



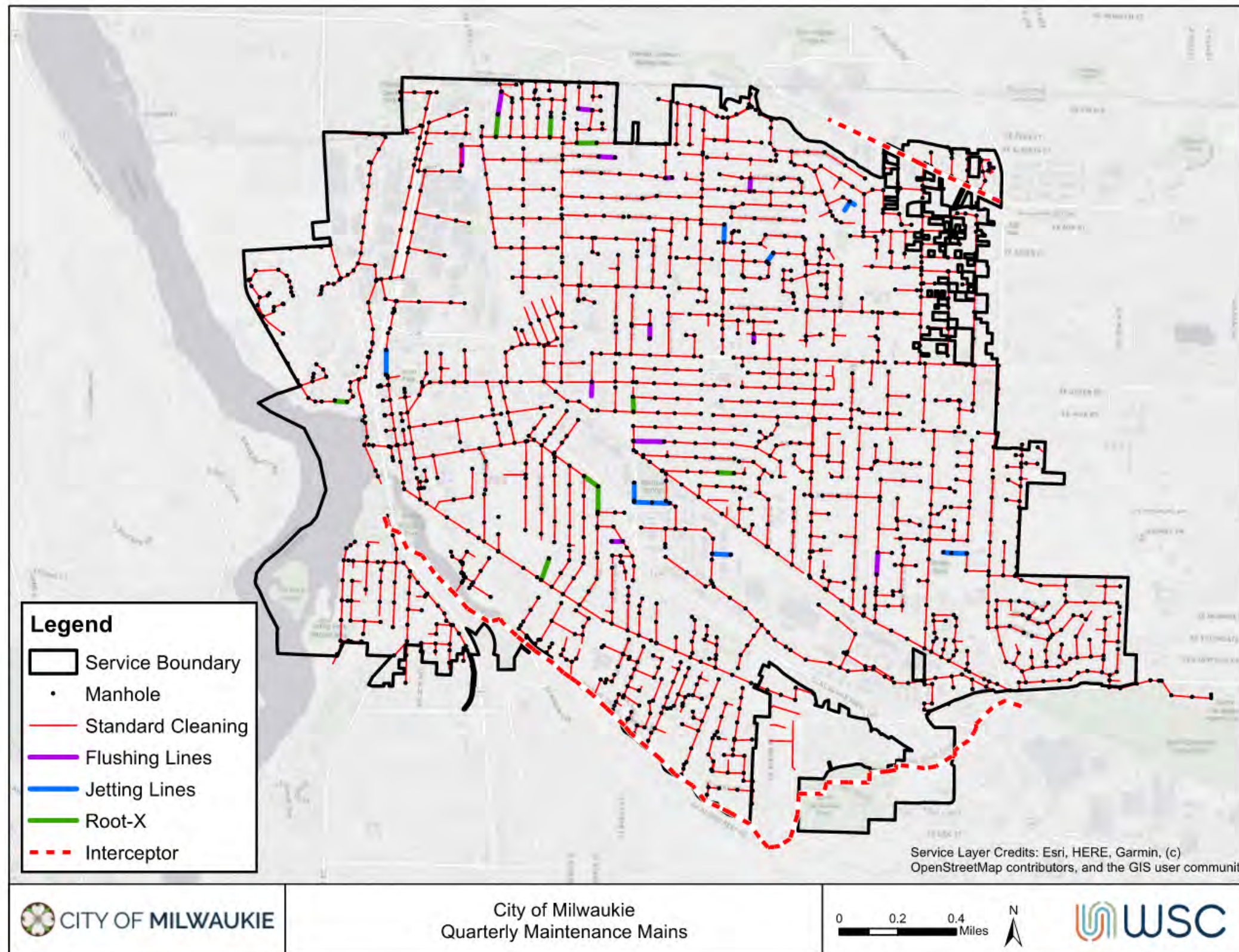


Figure 3-5: Mains Requiring Quarterly Maintenance

CHAPTER 4

# Agreements, Rules, and Regulations

This section describes the existing interagency agreements that the City maintains with adjacent sewer providers and provides an overview of the regulatory rules and policies the City operates within.

## 4.1 Interagency Agreements

The City maintains three intergovernmental agreements (IGAs) for the collection and treatment of wastewater with the neighboring sewer providers including Clackamas WES, the City of Portland, and Oak Lodge. Each IGA is briefly summarized below.

---

### IN THIS SECTION

Interagency Agreements  
Rules and Regulations

---

### 4.1.1 Clackamas WES

The City entered into an IGA with Clackamas WES (formerly Clackamas County Service District No. 1) on July 1, 2012 for wastewater treatment services. This agreement is attached as Appendix A. Under this agreement, the City agrees to pay WES a per-equivalent dwelling unit (EDU) wholesale rate equivalent to the wholesale rate of in-district WES customers for the treatment of the City’s wastewater. In addition, the City must pay WES the equivalent of a wholesale SDC for any new connections to WES’ system added after the agreement went into effect.

Under the agreement, the City is responsible for providing all collection sewer services, billing, inspection, and any other services required for operating and maintaining a sewer collection service. WES is responsible for operating and maintaining their own conveyance system and sewer treatment facilities. WES can also provide laboratory services for the City, if requested, at the rates included in the agreement.



As part of this agreement, the City and WES acknowledged the importance of identifying and remedying RDII problems within their respective collection systems, as excessive RDII can lead to treatment failure at the Kellogg Creek WRRF. If two or more permit violations occur within a calendar year at the Kellogg Creek WRRF, the City and WES must each conduct an investigation of their respective conveyance systems to identify and remedy any RDII problems to maintain a maximum peaking factor of 4:1 above average dry weather flow (ADWF). To this end, WES has agreed to contribute ten percent (10%) of the City's costs for all wastewater conveyance infrastructure designed to reduce RDII within the City's system. To obtain this funding, the City must provide a list of anticipated projects to Clackamas WES by February 15<sup>th</sup> of each year. WES will review these projects to determine their impact on RDII and provide a written response by March 15<sup>th</sup> that outlines how much of the project is, in their opinion, related to RDII mitigation and thus eligible for a contribution.

WES updated their SSSMP in January 2019. As part of the plan, WES evaluated their RDII and determined that all sub-basins must reduce their RDII by 65% to allow WES to provide the most cost-effective solutions for providing sufficient capacity within the treatment system. The SSSMP identified the Milwaukie Basin as priority 18 out of 19 for RDII reduction. However, the Milwaukie Basin was identified as a top priority by WES for early RDII reduction behind only Mount Talbert and the Happy Valley Interceptor Basin due to the capacity limitations at the Kellogg Creek WRRF. By reducing RDII within Milwaukie, WES hopes to create additional capacity within the Kellogg Creek WRRF that will allow them to delay other elements of their capital improvement program.

#### 4.1.2 City of Portland

The City entered into an IGA with the City of Portland in 1978 to create a means for providing sanitary sewer services to properties located within each city's jurisdiction. The agreement established responsibilities for each party and established a framework for charging for collection of properties located within the other city's jurisdiction. This agreement was amended in 1987 to allow the City of Milwaukie to annex and serve properties within its urban services boundary. The agreement auto-renews every five years unless each city seeks to modify or terminate the agreement. The original 1978 IGA is included as Appendix B.

#### 4.1.3 Oak Lodge Water Services District

The City entered into an IGA with Oak Lodge to provide a means for each agency to provide wastewater services for select properties within each other's jurisdictions. This agreement establishes which properties within each jurisdiction will be served by the other jurisdiction and establishes the rate of service as the prevailing rate of each party. This IGA is included as Appendix C.

### 4.2 Rules and Regulations

The following rules and regulations are relevant to the City's collection system.

#### 4.2.1 Oregon Administrative Rule, Chapter 660

Oregon Administrative Rule (OAR) 660-11 states “a city or county shall develop and adopt a public facility plan for areas within an urban growth boundary containing a population greater than 2,500 persons. The purpose of the plan is to help assure that urban development in such urban growth boundaries is guided and supported by types and levels of urban facilities and services appropriate for the needs and requirements of the urban areas to be serviced, and that those facilities and services are provided in a timely, orderly and efficient arrangement...”. (11) This WWSMP was developed in accordance with OAR 660-11 and will be used as the basis for the development of the City’s Wastewater Element of their Public Facilities Plan. The Wastewater Element shall summarize the key findings of this WWSMP and shall satisfy the wastewater-related components of OAR 660-11. The WWSMP will also serve as a supporting document to the City’s Comprehensive Plan.

#### 4.2.2 Oregon Administrative Rule, Chapter 340

OAR 340 establishes the authority of the Oregon Department of Environmental Quality (DEQ). Under Division 42, total maximum daily loads (TMDLs) are authorized for pollutants in waters of the state that are listed in accordance with the Federal Water Pollution Control Act, Section 303(d). In September 2006, DEQ established TMDLs for the Willamette Basin, which includes the Willamette River. The City only operates a collection system that conveys wastewater to WRRFs operated by Clackamas WES, City of Portland, and Oak Lodge. As such, they do not directly discharge to the Willamette River or any other water body. The City does not have a National Pollutant Discharge Elimination System (NPDES) permit with the Oregon DEQ, as NPDES permits are issued to the agency operating the WRRF.

#### 4.2.3 Oregon Revised Statute, Chapter 224

Oregon Revised Statute (ORS) 224 governs the management of the City’s wastewater collection system. The statute establishes the authority of the City to construct and operate a sewer system, including imposing a sewer charge on water users to fund planning, construction and operation of the sewer system.

#### 4.2.4 Oregon Revised Statute, Chapter 223

ORS 223 establishes the framework for the City to impose SDCs for capital improvement projects resulting from growth and development within the City. Under this statute, an SDC can be imposed upon a developer to fund the proportional share of expenses for capital improvements resulting from the increased demands the development puts on the system. SDCs can be improvement fees for costs associated with capital improvements that must be constructed as a result of the development, reimbursement fees for costs associated with modifying capital improvements already constructed or under construction when the fee is established to accommodate the development, or a combination of the two. Prior to establishing an SDC, the City must prepare a plan that identifies a list of capital improvement projects that the City intends to fund wholly or in part with the revenue from the SDC, the estimated cost of the project, timing, and the percentage of costs eligible to be funded by the SDC. This WWSMP will serve as this plan. SDCs are further discussed in Chapter 10.

## CHAPTER 5

# Flows & Loads

This chapter of the WWSMP identifies the existing wastewater flows within the City’s collection system and projects future flows. The chapter will cover anticipated population growth within the City; determination of the existing system flow through the analysis of flow monitoring results, water consumption billing records, and land use data; and projected future flows using the City’s updated buildable lands inventory (BLI).

## 5.1 Historic and Future Population Growth

Population growth was estimated using a three-step process: (1) estimating the population per household, (2) determining the number of households at buildout using a BLI, and (3) applying the average population per household to the number of future of households.

### 5.1.1 Population Per Household

Population data for the Portland Metro area is managed by two agencies: Portland State University (PSU) and Metro. PSU provides population estimates for past years while Metro provides population and household forecasts. Metro provides a household forecast every six years, with the latest forecast conducted in 2016 using 2015 population and household data. Using this data, WSC established an average population per household.

---

### IN THIS SECTION

Historic & Future  
Population Growth

Elements of Total  
Wastewater Flow

Existing Flow  
Development

Future Flow and Load  
Development

---

**Table 5-1: Population Per Household in Milwaukie City Limits**

Year	PSU Certified Population (12)	Metro Household Estimate (13)	Average Population Per Household
2015	20,505	8,677	2.36

### 5.1.2 Buildout Development

In August 2020, the City adopted a new Comprehensive Plan Policy Document with the goals of increasing housing options within the City through changes to zoning code. Proposed changes would promote densification through infill development within hubs and corridors to create complete neighborhoods (14). To estimate future population, a BLI was prepared to estimate the number of new housing units that are possible. The BLI included infill development within single family residential zones to account for expansion of middle housing as intended by House Bill 2001 passed in 2019 to promote more affordable housing within Oregon cities. The assumptions and data used to develop the BLI are provided within a Methodology and Initial Results Technical Memorandum prepared by Angelo Planning Group that is included as Appendix D of this WWSMP.

To estimate the buildout population, the current average of 2.36 people per household was applied to the number of households at buildout.

**Table 5-2: Buildout Population**

Buildout Households From BLI	Average Population Per Household	Projected Buildout Population
10,704	2.36	25,261

### 5.1.3 Future Population Projections

The BLI provides a population estimate assuming all buildable parcels are developed; however, this is not expected during the next 20 years. The City has estimated that 80% of the possible growth identified in the BLI will occur by the year 2040, which results in a population of 24,356 people and represents a cumulative population growth of 18 percent over the next 20 years. Metro estimated the City's population for 2040 as 23,149 people as part of their latest household forecast. The estimate using the BLI and City's growth assumptions is higher than the population projection by Metro but it is believed to better capture the anticipated growth since it is based upon the proposed zoning policy changes in the City's latest Comprehensive Plan.

A summary of the City's historical and projected population is provided in Table 5-3.

**Table 5-3: Historical and Projected Population Growth for the City of Milwaukie**

Year	Population
2015	20,505
2016	20,510
2017	20,550
2018	20,525
2019	20,535
2020	20,600
2040	24,356
Buildout	25,261

## 5.2 Elements of Total Wastewater Flow

To evaluate the hydraulic performance of the wastewater collection system, the volume of wastewater flow entering the system must be estimated. Wastewater flows consist of two general components: ground water dry weather flow (DWF) and RDII, as shown in Figure 5-1.

**Dry Weather Flow:** For the purposes of this plan, DWF is defined as the wastewater flow entering the system during periods of dry weather (i.e. no rain). The sources of DWF are service lateral connections and groundwater infiltration (GWI) in areas where collection sewer pipes are below the normal dry weather seasonal groundwater surface elevation. DWF typically follows a diurnal pattern based on customer's water consumption patterns with typical peaks in the morning and evening. GWI consists of groundwater entering the wastewater collection system through faulty pipe joints, cracks in the pipe, and cracks in manhole walls. GWI occurs when the groundwater table is higher than the pipe invert, varies based on the level of the groundwater table, and is often seasonal due to the groundwater table fluctuating throughout the year. Flow monitoring data indicated that GWI was not a significant factor in the City's DWF.

**RDII:** RDII, also called Wet Weather flow (WWF), represents the portion of wastewater flow that results from inflow and infiltration during and following a rainstorm. Inflow occurs when stormwater rapidly flows into sewers during and following a rain event, such as through holes in manhole covers or from storm drain cross connections. Infiltration occurs when rain temporarily saturates the soil surrounding sewer mains during and for a period after a storm, and groundwater seeps into the sewer pipes through faulty pipe joints, cracks in the pipe, and cracks in the manhole walls.

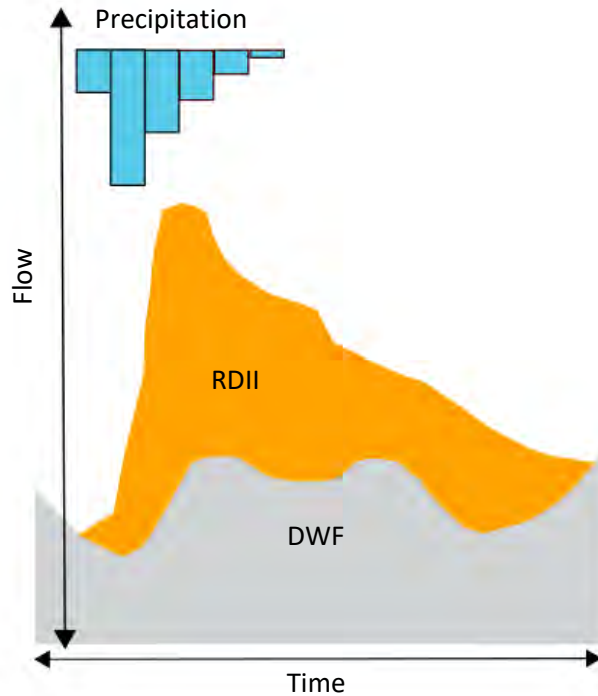


Figure 5-1: Components of Wastewater Flow (15)

### 5.3 Existing Flow Development

Existing wastewater flows were developed using flow monitoring data, water consumption data, and land use data to develop an ADWF that is geospatially allocated across the existing system. Precipitation data collected during the sewer flow monitoring was used to determine the relationship between RDII and rainfall in each basin. The RDII to rainfall relationship was then applied to the design storm to estimate existing WWF throughout the system.

#### 5.3.1 Flow Monitoring

The City does not currently conduct flow monitoring on a regular basis within the collection system. Clackamas WES collects data from two permanent flow monitors at transition points from the City owned collection system to the County's treatment and conveyance infrastructure. To better understand and characterize existing flow, the City determined that flow monitoring would be valuable to inform the WWSMP update.

Flow monitoring was conducted by SFE Global at six locations throughout the City’s collection system, as shown in Figure 5-2. Flow meters were allocated to the Brookside, North Milwaukie, Mid Milwaukie, South Milwaukie, and Harmony Basins. Two meters were placed in the Harmony Basin as the western half of the basin contains a large portion of the City’s industrial users while the eastern half of the basin is primarily residential. Flow monitors were not placed in the Johnson Creek and Lower Kellogg Basins as these basins do not have sufficient locations for monitoring upstream of connections to the City of Portland and Clackamas WES respectively. Two temporary rain gauges were also deployed during the periods of flow monitoring to capture and record the volume, duration, and intensity of any precipitation events. One rain gauge was located on the roof of City Hall in Downtown Milwaukie while the other was located at the Public Works Facility on Johnson Creek.

Flow meters were deployed from May 2, 2019 to June 4, 2019 and from November 18, 2019 to February 20, 2020 to capture flows during dry and wet weather periods. The period from May 3, 2019 to May 14, 2019 was used to calculate the ADWF in the collection system. This period was selected as no rain occurred on these days and conditions were dry prior to the monitoring. However, the second round of flow monitoring indicated there was an anomaly in the data for flow monitor (FM) 6 during this period, so the next driest period of November 18, 2019 to November 22, 2019 was used for determining DWF in FM 6. A detailed description of the flow monitoring and the data collected is provided in a Flow Monitoring Technical Memorandum provided as Appendix E to this WWSMP. The ADWF measured at each flow meter in gallons per day is provided in Table 5-4.

**Table 5-4: Dry Weather Flow Monitoring Results**

Flow Monitor	Representative Sewer Basin	Average Dry Weather Flow (gpd <sup>1</sup> )
1	Brookside	160,692
2	North Milwaukie and Brookside	473,111 <sup>2</sup>
3	Mid Milwaukie	199,527
4	South Milwaukie	57,013
5	Harmony – West (Industrial)	441,715
6	Harmony – East (Residential)	203,265 <sup>3</sup>
<ol style="list-style-type: none"> <li>1. gpd = Gallons per Day</li> <li>2. Flow at FM 2 captures all of the North Milwaukie Basin and all of the Brookside Basin</li> <li>3. Average dry weather flow for FM 6 was modified from the initial flow monitoring period (5/3/19 to 5/14/19) to a dry period in the second round of flow monitoring (11/18/19 to 11/22/19).</li> </ol>		



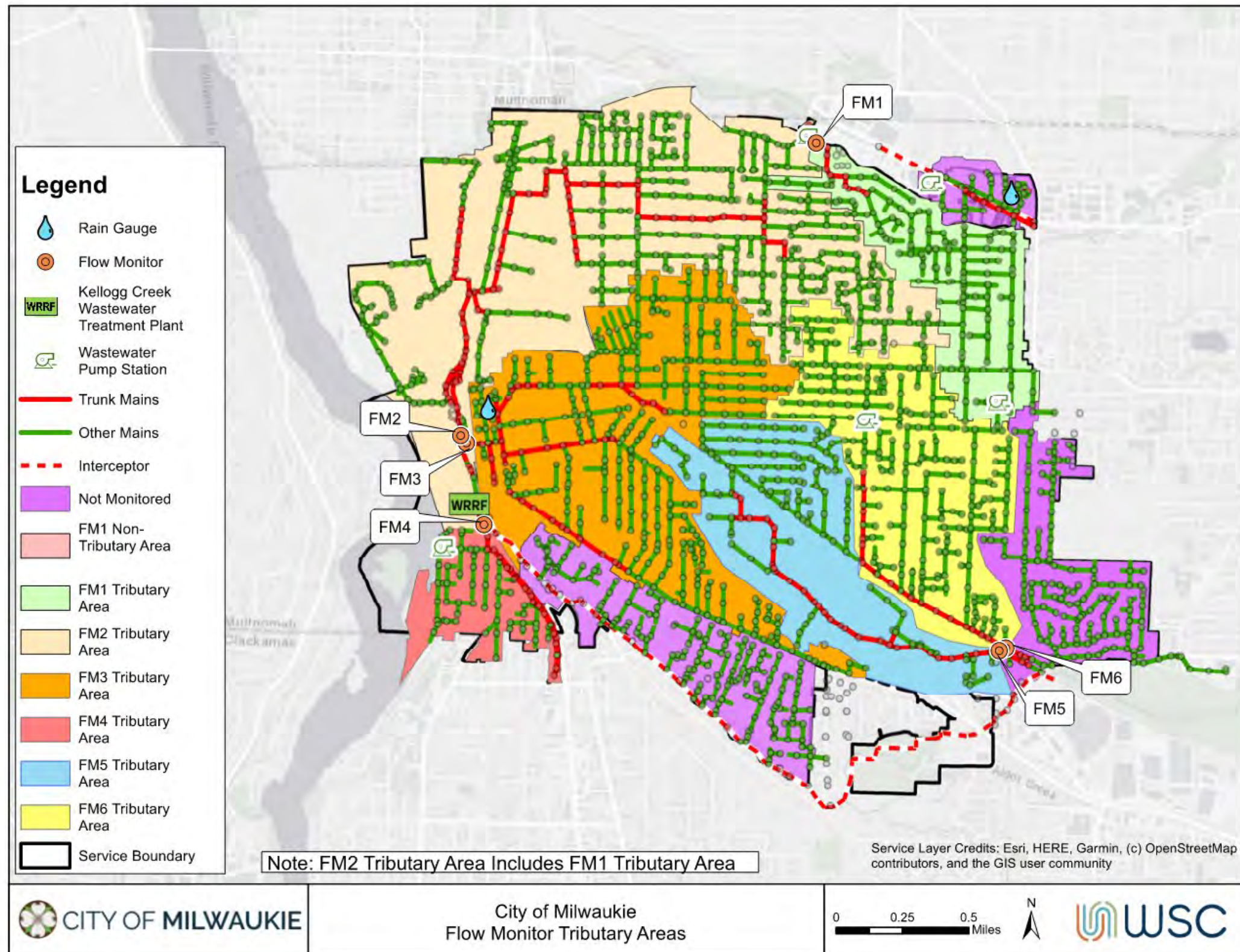


Figure 5-2: Flow Monitoring Locations and Tributary Area



### 5.3.2 Existing Dry Weather Flow

To properly model the collection system, the City's sewer flows need to be geospatially allocated and account for diurnal variations. The following sections describe the methods used to develop diurnal curves and allocate flows across the system.

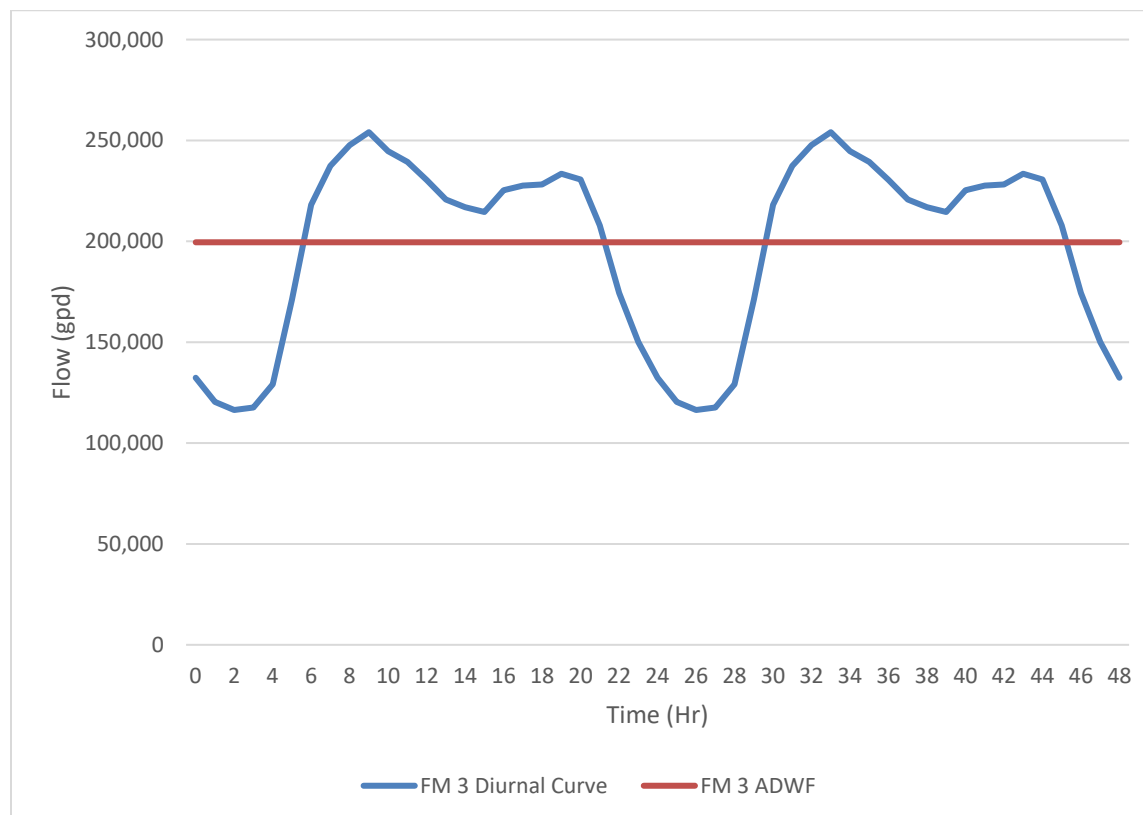
#### 5.3.2.1 Diurnal Curves

WSC developed diurnal curves for each of the flow monitors to estimate the variability of the City's flow over a typical day. Using the hourly data during the DWF monitoring period, WSC identified a diurnal curve factor for each flow monitor by dividing the average flow for that hour by the average daily flow. The diurnal curve was developed by multiplying each hourly factor by the ADWF and plotting the results over time. Peaking factors for each flow monitor are provided in Table 5-5. The diurnal curve for FM 3 is shown in Figure 5-3 as a representative sample of the diurnal curves developed.

**Table 5-5: Peaking Factors by Flow Monitoring Basin**

Flow Monitor	Average Dry Weather Flow (gpd)	Peak Diurnal Multiplier	Minimum Diurnal Multiplier
1	160,692	1.3	0.54
2	473,111	1.4	0.45
3	199,527	1.3	0.58
4	57,013	1.3	0.48
5	441,715	1.2	0.78
6	203,265	1.3	0.52

gpd = gallons per day



**Figure 5-3: Diurnal Curve for Flow Monitor 3**

### 5.3.2.2 Spatial Allocation of Flow

#### 5.3.2.2.1 Allocating Flow to Parcels Captured by Flow Monitors

WSC spatially allocated the ADWF determined from flow monitoring by examining water consumption records and using them to relatively allocate flow among the connections to the collection system. Water meter billing records are readily available and can be tied to each parcel using the billing address or meter number. By comparing a connection's water use relative to the total water use in a flow monitoring basin, the monitored wastewater flow can be allocated such that the larger water users produce the largest wastewater flow and the smaller water users produce smaller wastewater flows. The water billing period from November 15, 2019 to December 15, 2019 was selected for this analysis as the total water usage aligned with total wastewater meter data and occurred during the winter season when most of the water use occurs indoors.

### 5.3.2.2.2 Allocating Flow to Parcels Not Captured by Flow Monitors

The flow monitoring tributary areas roughly correlated with the City's sewer basins but in some cases omitted portions of a basin. FM 1 did not fully capture the Brookside Basin and FM 6 did not fully capture the southeastern Harmony Basin as shown in Figure 5-2. The Johnson Creek Basin and Lower Kellogg Basins were not monitored as discussed in Section 5.3.1. For these areas, flow was estimated by using the flow factor of the most representative flow monitoring basin to project total flow. Residential flow factors were determined by dividing the total flow associated with residential parcels in a flow monitoring basin by the number of dwelling units to develop an average flow/dwelling unit. Similarly, non-residential flow factors were determined by dividing the total flow associated with non-residential parcels in a flow monitoring basin by the acreage of those parcels to develop an average flow/acre. Once total flow was estimated for each of these non-monitored areas, the flow was allocated to each parcel relative to the parcel's water consumption in the same manner as described in Section 5.3.2.2.1.

### 5.3.2.2.3 Final Allocation of Flow

ADWF for each basin was determined by summing the estimated flows for all the parcels within each of the City's sewer basins. The resulting flows and their respective flow factors are included in Table 5-6.

Residential flow factors varied by basin from 63 gpd/EDU to 208 gpd/EDU, with a weighted average factor of 115 gpd/EDU across all flow monitored tributary areas. The average flow per EDU calculated from flow monitoring results is lower than the residential values used in other sewer system master plans in the Milwaukie area, as shown in Table 5-7. Values typically range between 150 gpd/dwelling unit and 200 gpd/dwelling unit for other sewer collection systems in the area. Following discussions with the City, the factor of 115 gpd/EDU was agreed to be reasonable for projecting BWF from future projected growth which will primarily consist of infill through densification. A large quantity of the projected growth in EDUs is anticipated to come from the converting current single-family zoned properties into multi-family properties or from construction of multi-family housing within mixed use zoned properties. In Wastewater Engineering the average loading per capita for an apartment is 38 gpd. With an average of 2.3 people per EDU, the resulting loading would be 87 gpd/EDU. Using the weighted average loading factor of 115 gpd/EDU appears to be reasonable for projecting future growth anticipated to be mainly in the form of multi-family housing.

Non-residential flow factors varied from 163 gallons per acre per day (gpad) to 3,117 gpad with a weighted average factor of 1,529 gpad. This value is higher than the factors used for commercial and industrial flows in Milwaukie's neighboring collection systems but is within 40 percent of the values used by Clackamas WES for the SSSMP.

Table 5-6: Average Dry Weather Flow by Basin

Sewer Basin	Average Dry Weather Flow (gpd)	Residential Flow Factor (gpd/EDU)	Non-Residential Flow Factor (gpad)
Brookside Basin	188,830	208	1,077
North Milwaukie Basin	284,334	89	696
Mid Milwaukie Basin	199,527	63	986
South Milwaukie Basin	57,013	174	3,177
Harmony Basin – West (Industrial)	441,715	193	2,740
Harmony Basin – East (Residential)	337,179	144	163
Lower Kellogg Basin	56,744	64	986
Johnson Creek Basin	55,986	186	1,535
<b>Total Flow</b>	<b>1,621,328</b>	<b>115<sup>1</sup></b>	<b>1,529<sup>2</sup></b>
gpd = gallons per day    gpad = gallons per acre per day    EDU = equivalent dwelling unit 1. Weighted average of residential flow factors 2. Weighted average of non-residential flow factors			

Table 5-7: Past Master Plan Flow Factors

Source	Residential Flow (gpd/EDU)	Non-Residential Flow (gpad)
Milwaukie 2010 Wastewater Master Plan	190 (single family residential 79 for multi-family residential)	Not Provided
Sanitary Sewer System Master Plan for Water Environment Services (2020)	148	1,100 commercial and industrial 400 – 33,800 for mixed use of varying densities
Oregon City Sanitary Sewer Master Plan (2014)	190	Not provided
City of Gladstone Sanitary Sewer Master Plan (2017)	232	818
gpd/EDU = gallons per day per equivalent dwelling unit    gpad = gallons per acre per day		

### 5.3.3 Existing Wet Weather Flow

Determining the existing wet weather flow consisted of developing RTK parameters for modeling the RDII response to a monitored rain event, selecting an appropriate design storm, and estimating RDII under the design storm conditions.

### 5.3.3.1 RTK Method

WWF monitoring was used to capture rainstorm data and understand how the City’s collection system responds to a storm. The goal of this monitoring was to capture a system stressing rain event to understand RDII within the City’s collection system. “System stressing events are typically more than one inch of rainfall in a 24-hour period.” (16) Table 5-8 shows the results of the top storms captured during the monitoring period.

**Table 5-8: Top Ten Rain Events (24 Hour) by Total Rain During Wet Weather Flow Monitoring**

Period	Total Rain (inches)	Peak Rain Intensity (inches per hour)
January 27, 2020 11:30 am – January 28, 2020 11:30 am	1.30	0.20
December 20, 2019 5:20 pm – December 21, 2020 5:20 pm	1.03	0.09
December 6, 2019 7:25 pm – December 7, 2019 7:25 pm	0.94	0.14
January 23, 2020 8:25 am – January 24, 2020 8:25 am	0.84	0.14
January 10, 2020 11:20 am – January 11, 2020 11:20 am	0.79	0.14
February 15, 2020 2:30 am – February 16, 2020 2:30 am	0.74	0.12
December 18, 2019 7:05 am – December 19, 2019 7:05 am	0.70	0.17
December 11, 2019 12:55 pm – December 12, 2019 12:55 pm	0.64	0.25
January 25, 2020 9:30 pm – January 26, 2020 9:30 pm	0.62	0.18
January 29, 2020 5:30 am – January 30, 2020 5:30 am	0.55	0.12

The RTK unit hydrograph method (RTK method) was used to estimate the impacts of RDII on the collection system flows. The RTK method uses a series of three triangular unit hydrographs to model an observed RDII hydrograph based on flow monitoring data (Figure 5-4). The first unit hydrograph models the rapid response to the rain event and includes primarily inflow into the collection system. The second unit hydrograph models the medium response that includes both inflow and infiltration components. The third unit hydrograph models the slow response to the rain event and includes infiltration, which can persist long after the storm has ended. The combination of the three unit hydrographs creates the modeled total RDII hydrograph. (15)

Each unit hydrograph is defined by three parameters:

- R – Fraction of rainfall falling that enters the collection system as RDII.
- T – Time to peak RDII flow (measured in hours)
- K – Ratio of the time of recession to the time of peak flow

These parameters were iterated using typical values until the modeled hydrograph aligned with the hydrograph from the storm beginning on January 27, 2020. This storm was selected as it had the largest volume of rain over a 24-hour period while having the second highest peak rain intensity. These two factors made it the storm with the largest RDII response.

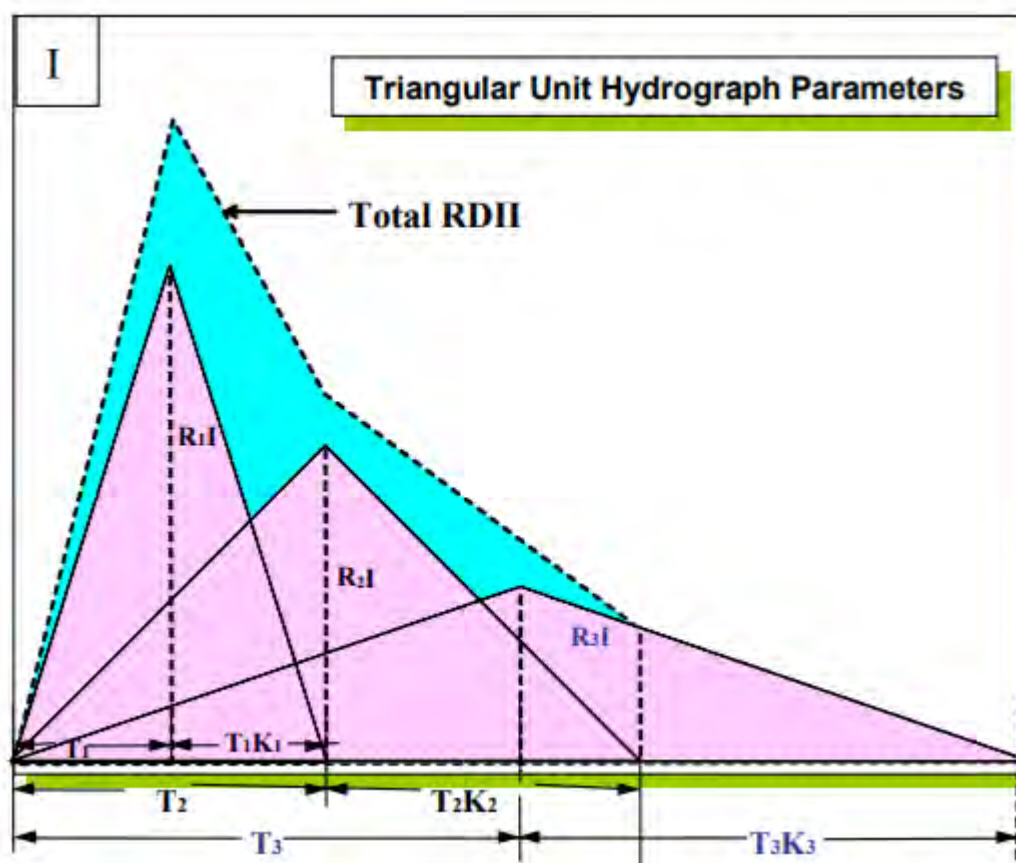
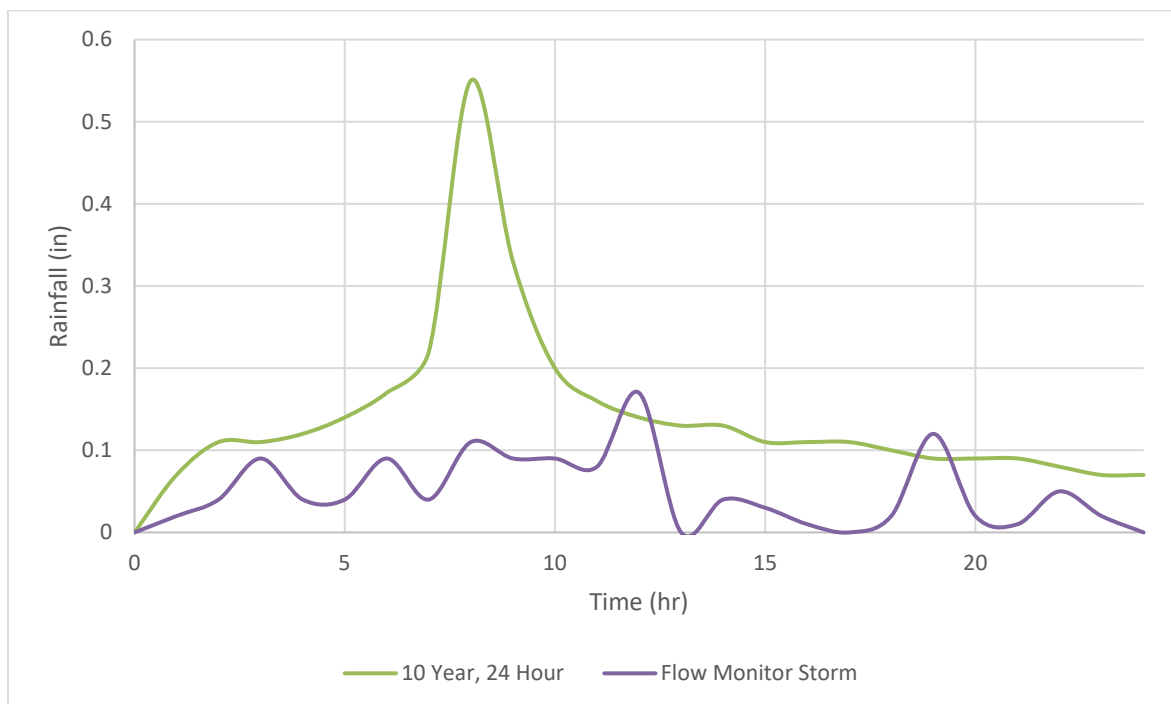


Figure 5-4: RTK Unit Hydrograph Parameters (15)

### 5.3.3.2 Selection of Design Storm

A design storm must be selected to evaluate the collection system's ability to handle wet weather flows under both existing and future conditions. Selecting the size of the design storm is the responsibility of the owner of the collection system but the Oregon DEQ provides guidance as to what is acceptable. According to OAR 340-041-0009 (7) and (8), all sanitary sewer overflows are prohibited. However, DEQ may withhold enforcement action for an SSO that occurs during larger storm events, defined as a 10-year storm, 24-hour duration for summer months and a 5-year storm, 24-hour duration for winter months. Based on this guidance, the City selected a 10-year storm, 24-hour duration for the design storm as this is the more conservative storm. According to the City's Stormwater Master Plan, a 10-year storm, 24-hour duration has a total of 3.5 inches of rain over 24 hours and follows the Soil and Conservation Service (SCS) 24-hour, Type IA distribution. (17) Figure 5-5 shows the design storm hyetograph relative to the largest storm captured during flow monitoring.



**Figure 5-5: Comparison of Storm Hyetographs**

#### 5.3.4 Rainfall Dependent Inflow and Infiltration (RDII)

Existing RDII was determined by subtracting the WWF from the ADWF for each flow monitoring basin to determine the portion of flow that was attributed to RDII under the design storm conditions. The design storm was modeled by applying the existing DWF described in Section 5.3.2 to the hydraulic model with the RTK values determined for each flow monitoring area (Section 5.3.3.1) and the hyetograph of the design storm. More information on the hydraulic model is included in Chapter 6 of this WWSMP.

The areas not captured by flow meters were assigned the RTK parameters of the most similar basin. These basins are identified in Table 5-9.

**Table 5-9: RTK Parameters for Unmonitored Areas**

Unmonitored Area	Basis of RTK Parameters
Unmonitored Area of Brookside Basin	FM 1
Unmonitored Area of Harmony Basin	FM 6
Johnson Creek Basin	FM 1
Lower Kellogg Basin	FM 4

The resulting RDII for each of the flow monitoring basins is provided in Table 5-10 and Table 5-11. When normalized for area, the eastern Harmony Basin has the lowest RDII per acre and is almost six times less than the western Harmony Basin. Piping in the eastern Harmony basin is similar in age to the piping in the western Harmony Basin, so a similar rate of RDII would be expected. Additional flow monitoring is recommended in the eastern Harmony Basin to confirm the RDII levels are much lower than the other basins. Smoke testing in the industrial western Harmony Basin may also be beneficial as there could be storm drains inadvertently connected directly to the sewer system causing elevated RDII. The need for additional smoke testing could be evaluated during the planning of the next flow monitoring effort.

WSC compared peak WWF at the Milwaukie meter under the same storm conditions Clackamas WES used in their master plan. The model indicated a peak flow of approximately 7.6 MGD compared to WES' 2015 peak flow of 8.0 MGD. The estimated peak flow is within 5 percent of WES' data. The difference could be attributed to RDII reduction from clay pipe replacement completed by the City over the past 5 years. Additionally, a portion of the difference could be attributed to flow meter accuracy, as WES' permanent flow meters are likely to read slightly differently than those used during the City's flow monitoring.

**Table 5-10: Peak Wet Weather Flow Under Storm Conditions**

Flow Meter	Dry Weather Flow at Peak Wet Weather Flow (gpd)	Peak Wet Weather Flow (gpd) Modeled Design Storm	Peak Rainfall Dependent Infiltration and Inflow (gpd)
1	189,286	1,276,853	1,087,567
2	655,042	4,508,273	3,853,232
3	171,118	1,541,254	1,370,136
4	76,440	699,543	623,104
5	421,854	2,317,417	1,895,563
6	239,767 <sup>A</sup>	625,942	386,175

gpd = gallons per day

**Table 5-11: RDII by Flow Monitoring Basin**

Flow Meter	City Basin	Peak RDII (gpad)
1	Brookside	4,540
2	North Milwaukie/Brookside	1,231
3	Mid Milwaukie	2,286
4	South Milwaukie	5,328
5	Harmony – West (Industrial)	5,327
6	Harmony – East (Residential)	930

gpad = gallons per acre per day

## 5.4 Future Flow and Load Development

Future DWF was estimated using the updated BLI discussed in Section 5.1. Future WWF or RDII was estimated by modeling the design storm to align with the diurnal peak DWF to develop a conservative estimate for peak WWF to evaluate capacity.



### 5.4.1 Future Dry Weather Flow

The future DWF was projected by applying flow factors to the BLI calculation for new EDUs for all parcels identified for potential future infill development based on their zoning. These flow factors are based on the weighted average of the flow factors for each basin under existing conditions. All future residential units identified within the BLI received a residential flow based on the residential flow factor shown in Table 5-13. Non-residential growth was limited to parcels identified for development as part of the neighborhood mixed use hubs within the BLI. The non-residential flow factor (Table 5-13) was applied to the percentage of these parcels designated for non-residential uses to project non-residential flow.

The BLI was developed prior to the preparation of any development plans. However, at the time of this WWSMP preparation, preliminary development plans were submitted for the Hillside Manor development indicating the actual number of EDUs to be constructed. The actual number of EDUs was within 2 percent of the quantity estimated in the BLI for that specific parcel, providing confidence in the magnitude of projections of new EDUs included in the BLI for future development. For the purposes of estimating DWF within the hydraulic model, the Hillside Manor parcel was revised to include 592 dwelling units instead of the predicted 600 dwelling units from the BLI analysis.

The projected total flows for each basin are included in Table 5-12. The flow factors used for each land use classification are provided in Table 5-13. Buildout flow is based on the total amount of future development identified within the BLI. The City estimates 80 percent of this buildout will occur by the year 2040. The year 2040 was selected to evaluate the collection system for deficiencies for a 20-year planning horizon.

**Table 5-12: Future Dry Weather Flow**

Basin	2040 Dry Weather Flow (gpd)	Buildout Dry Weather Flow (gpd)
Brookside	226,366	241,234
North Milwaukie	402,316	441,813
Mid Milwaukie	348,161	394,497
South Milwaukie	59,788	61,152
Harmony – West (Industrial)	445,687	446,925
Harmony – East (Residential)	395,894	416,380
Lower Kellogg	72,288	77,400
Johnson Creek	56,355	56,470
<b>Total Flow</b>	<b>2,006,855</b>	<b>2,135,870</b>
gpd = gallons per day		

Table 5-13: Loading by Zone Type

Classification	City Zoning	Description	Unit Load
Residential	Single Family Residential		
	R-10	Low Density Residential	115 gpd/EDU
	R-7	Low Density Residential	115 gpd/EDU
	R-5	Moderate Density Residential	115 gpd/EDU
	Multi-Family Residential		
	R-3	Medium Density Residential	115 gpd/EDU
	R-2.5	Medium Density Residential	115 gpd/EDU
	R-2	Medium Density Residential	115 gpd/EDU
	R-1	High Density Residential	115 gpd/EDU
	R-1 B	High Density Residential	115 gpd/EDU
	Non-Residential	Commercial	
NMU		Neighborhood Mixed Use	1,529 gpad
C-N		Neighborhood Commercial	1,529 gpad
C-L		Limited Commercial	1,529 gpad
C-G		General Commercial	1,529 gpad
G-CS		Community Shopping Commercial Zone	1,529 gpad
Industrial			
M		Manufacturing	1,529 gpad
BI		Business Industrial	1,529 gpad
MUTSA		Tacoma Station Area Mixed Use	1,529 gpad
NME		North Milwaukie Employment Zone	1,529 gpad
Mixed Use Residential (MUR)			
GMU		General Mixed Use	1,529 gpad
Note: Open Space (OS) was excluded from the analysis as there is no anticipated development. gpd/EDU = gallons per day per equivalent dwelling unit      gpad = gallons per acre per day			

## 5.4.2 Future Wet Weather Flow

Future WWF was determined by applying the same RTK parameters as those for the existing loading (Section 5.3.3.1) to the future DWF under the design storm (10-year, 24-hour storm). These parameters are basin-specific and do not change based on the DWF volume. Future peak WWF was estimated by superimposing the peak DWF contribution with the peak RDII from the design storm within the hydraulic model. This creates a conservative scenario for evaluating the capacity of the City's collection system as it estimates the highest flow that could be expected within the system. The summary of the peak WWF for the year 2040 and at buildout is presented in Table 5-14 and Table 5-15 respectively.

The DWF at the peak WWF presented in these tables is not the same as the ADWF due to the timing of the storm. The storm was imported into the model so that it maximized the wet weather flow in the system as a whole. Since each basin has unique RTK parameters, this results in the timing of the peak WWF differing slightly among the basins. Additionally, no degradation rate was applied to the system to approximate the increase in RDII that can occur over time as the collection sewer pipes age and deteriorate. The City regularly inspects and maintains the collection system so substantial system-wide degradation over time is not anticipated.

**Table 5-14: Wet Weather Flow for the Year 2040**

Flow Monitor	Basin	Dry Weather Flow at Peak Wet Weather Flow (gpd)	Peak Wet Weather Flow (gpd) Modeled Design Storm
1	Brookside	224,982	1,312,132
2	North Milwaukie/ Brookside	556,950	4,739,005
3	Mid Milwaukie	298,591	1,635,152
4	South Milwaukie	80,161	714,244
5	Harmony – West (Industrial)	425,648	2,320,480
6	Harmony – East (Residential)	299,099	661,189

gpd = gallons per day

**Table 5-15: Buildout Wet Weather Flow**

Flow Monitor	Basin	Dry Weather Flow at Peak Wet Weather Flow (gpd)	Peak Wet Weather Flow (gpd) Modeled Design Storm
1	Brookside	239,210	1,325,445
2	North Milwaukie/ Brookside	611,634	4,817,909
3	Mid Milwaukie	338,329	1,664,856
4	South Milwaukie	81,989	713,257
5	Harmony – West (Industrial)	426,830	2,321,367
6	Harmony – East (Residential)	315,581	691,746

gpd = gallons per day

## CHAPTER 6

# Hydraulic Model Development

This section summarizes the development of the City's wastewater collection system hydraulic model and model calibration results.

## 6.1 Model Development

WSC developed a model of the City's wastewater collection system in SewerGEMS, Bentley's® GIS-based hydraulic modeling software, using updated system information provided by the City. The objective of the model development was to construct a model representative of the City's wastewater collection system for use in simulating and predicting the performance of infrastructure under an array of differing flow conditions. The model was also used to evaluate recommended capital improvements based on the deficiencies identified in the capacity analysis.

---

### IN THIS SECTION

Model Development  
Model Loading  
Model Calibration

---

### 6.1.1 City GIS Data

The model was built by importing the City's GIS shapefiles for the collection system infrastructure into SewerGEMS. Key attributes from the City's shapefiles were extracted by SewerGEMS using its ModelBuilder tool to align the GIS parameters with parameters in the model. Table 6-1 shows which GIS attributes were used to build the model.

**Table 6-1: Model/GIS Attributes**

Model Attribute	Shapefile/Feature Class	Key Attributes	Data Source
Gravity Conduit/Pipe	ssMain	Facility Identifier 1 (Upstream Manhole), Facility Identifier 2 (Downstream Manhole), Material, Diameter, Downstream Elevation, Upstream Elevation, Pipe Type, Pipe Status	City
Manholes	ssManhole	Facility Identifier, Invert (Depth to Bottom), Invert Elevation, Rim Elevation, Drop Manhole	City
Force Main/Pressure Pipe	ssMain	Facility Identifier 1 (Upstream Manhole), Facility Identifier 2 (Downstream Manhole), Material, Diameter, Downstream Elevation, Upstream Elevation, Pipe Type, Pipe Status	City
Pump Station/Wet Well	ssManhole	Facility Identifier, Invert Elevation, Rim Elevation, Manhole Type, Drop Manhole	City
Property Connections	wMeter	Physical location (coordinates) used for property connections	City
Lower Kellogg Interceptor	LK_SS_lines	AssetID, Material, Diameter, From MH, To MH, Upelev, Downele,	WES

## 6.1.2 Manually Entered Data

This section describes the manual adjustments to City provided data and the assumptions that were used to create a functional hydraulic sewer model that reflects the existing system.

### 6.1.2.1 Invert Elevations

The City's GIS shapefiles were missing invert elevation and rim elevation data within their attribute table, which are essential for building a hydraulic model. The shapefiles contained field measured depths within the "Invert (Depth to Bottom)" field for each manhole, but these can only be converted to elevation data if manholes have rim elevations. Additionally, the measurement in this field is measured to the center of the manhole channel, which does not account for the slight elevation drop across the channel or for differing invert elevations of inflowing pipes. To calculate pipe invert elevations across the collection system, WSC spatially joined LIDAR surface elevation data from the Oregon Department of Geology and Mineral Industries (DOGAMI) to the City's collection system shapefiles in GIS to approximate rim elevations for the manholes. The LIDAR digital elevation model has a cell size of approximately three feet and an average vertical accuracy of +/- 3 centimeters (18). The measured "Invert (Depth to Bottom)" field for each manhole was subtracted from the ground surface elevation to calculate a manhole invert elevation.

Following the calculation of invert elevations within the GIS shape files, the data was imported into the hydraulic model for review. Manual adjustments were determined to be necessary to allow the model software to function properly, and the typical types of adjustments included:



- **Cleanouts with no depth data.** Pipes that originate at a cleanout rather than a manhole did not have depth data that could be used to calculate an invert elevation. Invert elevations were manually entered at connections to cleanouts using the known downstream elevation and assuming a minimum pipe slope in accordance with City design standards.
- **Connections to Non-City Manholes.** In both the Johnson Creek and Lower Kellogg basins, there are pipes that connect directly to manholes on the Lents Trunk (owned by Portland) and the Kellogg interceptor (owned by WES) respectively. Manhole depth information was not available for the manholes on the non-City owned interceptors. Invert elevations were manually entered at these manholes using the known upstream elevation and assuming a minimum pipe slope in accordance with City design standards.
- **Manholes with Bad Data.** Pipes with invert elevations that differed from adjacent pipe inverts by more than one foot were “flattened” to a minimum pipe slope in accordance with design standards. Of the 127 pipes in this category of manual adjustment, nearly 2/3 required an adjustment of more than 2 feet, and some pipes required adjustments over 20 feet. Invert elevations for these pipes should be confirmed through field survey to improve the accuracy of the model.
- **Negatively Sloped Pipes.** Pipes with invert elevations that created a slightly negative slope were adjusted to match the slope of adjacent pipes upstream and downstream. These adjustments were less than 1-foot in magnitude, and approximately one-half of these pipes required an adjustment of 3 inches or less. An example of a typical adjustment within this category is depicted in Figure 6-1 and Figure 6-2.

A summary of the number of pipes that required the manual adjustments described above is provided in Table 6-2.

**Table 6-2: Summary of Manual Adjustments to Pipe Invert Data**

Pipe Adjustment Category	Quantity of Pipes	Percentage of Total
Cleanouts w/ No Depth Data	134	7%
Connections to Non-City Manholes	109	6%
Manholes w/ Bad Data	127	6%
Negatively Sloped Pipes	179	9%
<b>Total Pipes Requiring Adjustment</b>	<b>549</b>	<b>28%</b>
No Adjustment	1378	72%
<b>Totals</b>	<b>1927</b>	<b>100%</b>

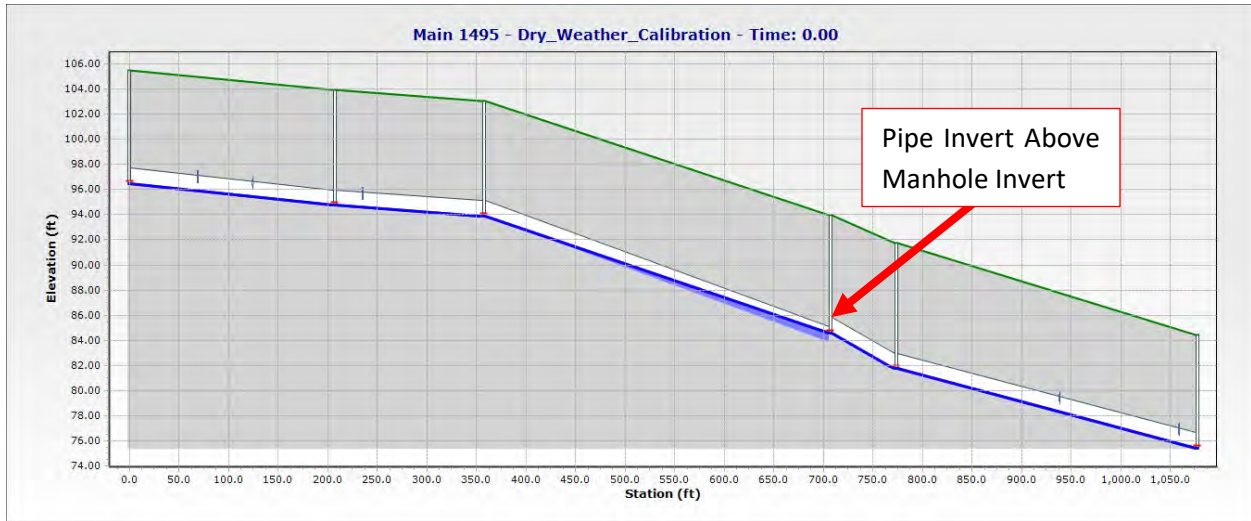


Figure 6-1: Sample Segment with Connectivity Issue

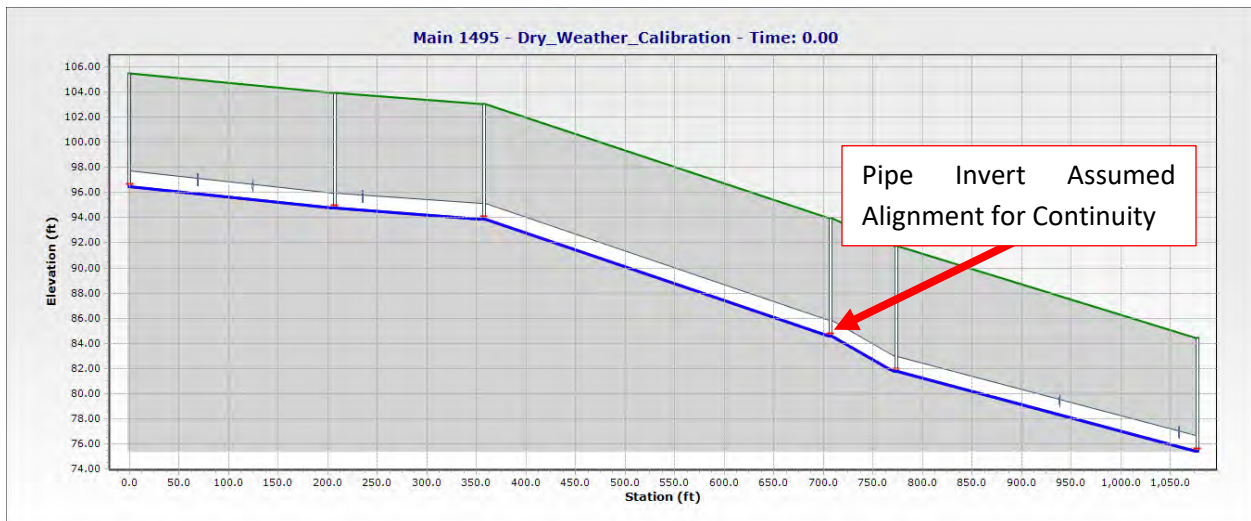


Figure 6-2: Sample Segment with Corrected Connectivity

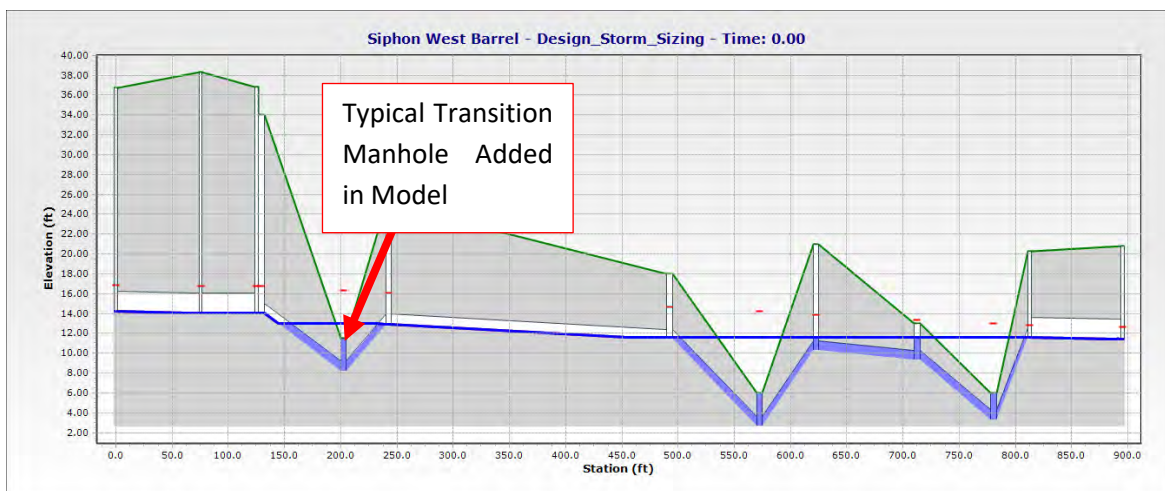
In discussing strategies for improving the accuracy of the model, WSC and the City developed a strategy for prioritization. When manual adjustments to pipe inverts were required to allow the hydraulic model to function, conservatively flat slopes were selected for the pipes and each segment was flagged in the model to indicate an adjustment was made. Pipelines that are found to have capacity deficiencies in the hydraulic evaluation can then be identified and prioritized for field surveying of invert elevations to confirm or modify hydraulic capacity improvement recommendations.

### 6.1.2.2 Pump Curves and Pump Station Set Points

WSC manually entered key pump station attributes into the hydraulic model to represent the current configuration and operational settings. The City provided available record drawings, operational set points, and pump curves for all five sewage pump stations. Using the record drawings, the wet well base elevation and pump elevations were input into the model and wet well high and low levels were established based on the set point data. Pump curves were input into the model using three points on the City provided pump curve, including the design operating point for each pump.

### 6.1.2.3 Siphons

The City's ssMains shapefile provided the locations and elevations of the Johnson Creek siphon, however some manual adjustment was required to represent hydraulic conditions in the siphon within the model. The GIS shapefile represented each barrel of the inverted siphon as a single pipe, which when imported into the model, does not accurately capture the profile of an inverted siphon. Manual insertion of transition manholes was required to better reflect the profile shown in the City's as-built drawings. Transition manholes in the model do not add inflow and cannot overflow. The transitions allow the model to create shorter pipe segments and create the changes in slope to reflect record drawing information (see Figure 6-3). Inverts at the start, middle, and end of the siphon were input into the model to reflect record drawing information.



**Figure 6-3: Modeling Siphons**

The Johnson Creek siphon consists of two parallel 12-inch diameter pipes with an inlet structure that limits flow to one pipeline during low flow periods so that velocities in the siphon are maintained and solid deposition is minimized. A weir in the inlet structure is set approximately 15 inches above the first pipe invert so that once the first siphon pipeline is flowing 60 percent full, flow will overtop the weir and into the second pipeline. To represent the flow distribution between the two barrels within the hydraulic model, an additional manhole was added upstream of each siphon barrel with one invert matching the pipe invert of 14.06 feet and the other set to match the top of the diversion weir at 15.26 feet. A cross-section of the siphon inlet structure and diversion weir from the record drawings is provided in Figure 6-4.

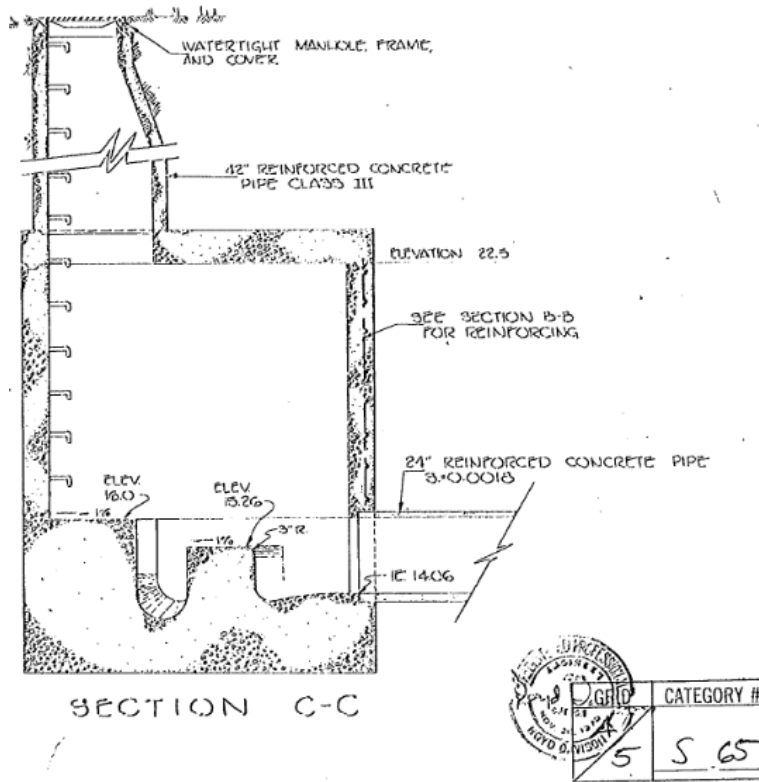
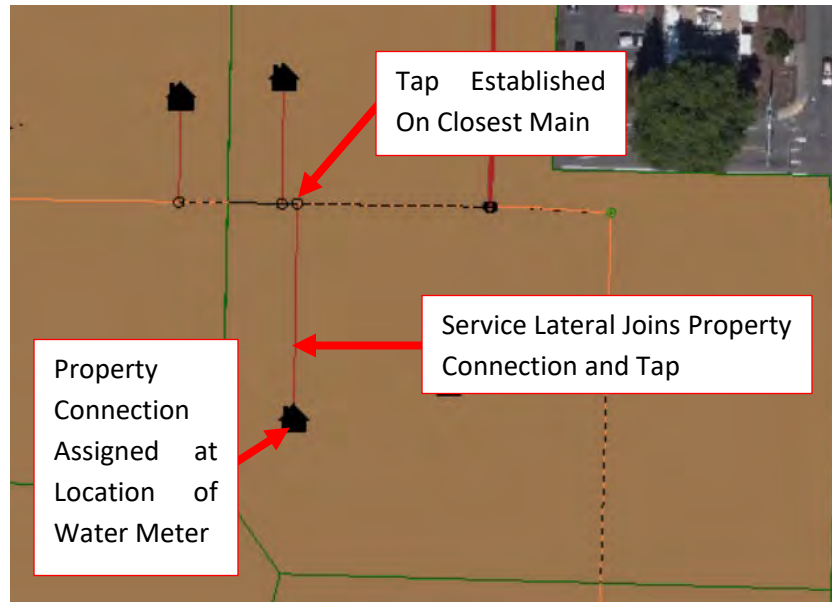


Figure 6-4. Johnson Creek Siphon Inlet Structure

## 6.2 Model Loading

This section describes how loads were assigned within the hydraulic model. A detailed description of the development of existing loading and projections of future loading is described in Chapter 5. Existing loads were spatially allocated in the model by placing a property connection at the physical location of the water meter in GIS. Within the model these property connections and their resulting load were assigned to the nearest gravity pipe, as shown in Figure 6-5.



**Figure 6-5: Assigning Property Connection Loads in the Model**

### 6.3 Model Calibration

The hydraulic model was compared to dry weather and wet weather flow monitoring data collected in the basin during the initial phases of the project. Initial flow monitoring was conducted from May 3, 2019 – June 4, 2019 but there was insufficient rain intensity during this time for accurately calibrating the model to wet weather conditions. A second round of flow monitoring was conducted from November 18, 2019 – February 20, 2020 to capture rainstorms suitable for calibrating the model to wet weather conditions. The locations of the flow monitors are shown in Chapter 5, Figure 5-2.

#### 6.3.1 Dry Weather Flow Verification

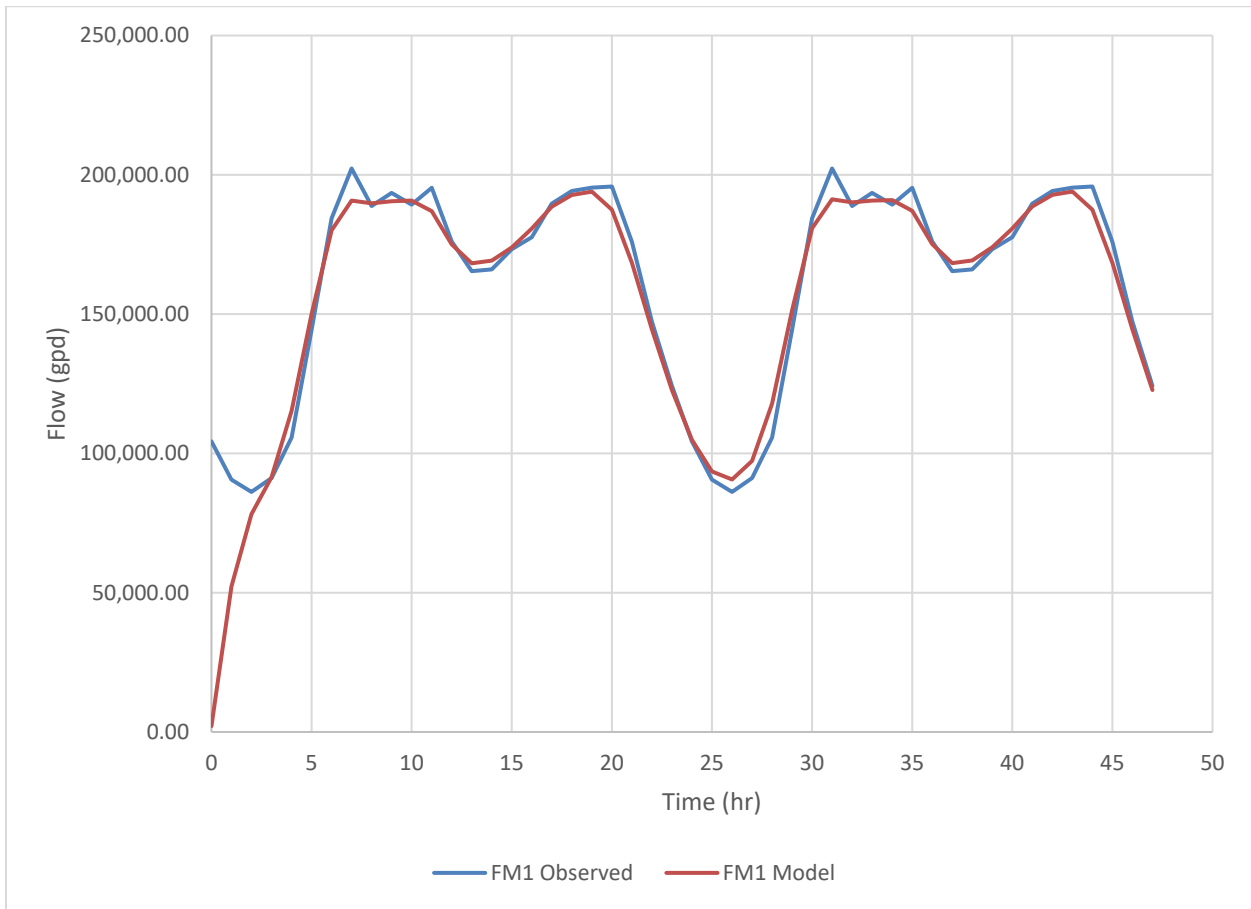
The period of May 3, 2019 through May 14, 2019 was selected for verifying DWF and loads within the model for FMs 1 through 5 as this was the longest period of flow monitoring data without rain. A dry weather period from November 18, 2019 to November 22, 2019 was used to verify dry weather flows and loads in the model for FM 6. Data collected at FM 6 in May of 2019 was questionable as it conflicted with data for the WES Harmony flow meter and FM 5, so the November period was determined to provide more trustworthy data for that flow monitor when compared with data from other sources.

DWF verification was achieved by comparing modeled flows to the observed flows at the locations of each of the six flow monitors to verify flow criteria such as the shape of the hydrograph, timing of peak flows and troughs, magnitude of peak flows, and total flow volume. A summary of the dry weather verification criteria is provided in Table 6-3.

**Table 6-3: Summary of Dry Weather Flow Verification**

Parameter	Criteria
Shape	The shape of the modeled hydrograph should visually align with the shape of the observed hydrograph.
Timing	Modeled peaks and troughs should be within 1 hour of the observed peaks and troughs.
Peak Flow	± 10% of observed peak flow
Flow Volume	± 10% of observed peak volume

Verification hydrographs were developed for the sewer shed contributing to each flow monitor location. Modeled DWF was then compared to the DWF during the verification period. An example comparison of modeled DWF to observed DWF is provided for FM 1 in Figure 6-6. The spatial allocation of the loading satisfied all dry weather verification criteria as shown by the results summary in Table 6-4.



**Figure 6-6: Dry Weather Flow Verification Hydrograph at Flow Monitor 1**



**Table 6-4: Dry Weather Flow Verification Results**

	FM1	FM2	FM3	FM4	FM5	FM6
Visually Aligned	Yes	Yes	Yes	Yes	Yes	Yes
Timing of Peaks and Troughs Aligned	Yes	Yes	Yes	Yes	Yes	Yes
Peak Flow (% of Observed)	-4.1%	-3.5%	-3.8%	-2.1%	-1.8%	-3.8%
Flow Volume (% of Observed)	-0.1%	+0.4%	+1.6%	+0.6%	-0.3%	-0.3%

### 6.3.2 Wet Weather Flow Development

The rain event from January 27, 2020 – January 28, 2020 was selected to develop a unit hydrograph within the model to predict WWF response in the collection system during and after a rain storm. The January 27-28 storm provided both the largest volume and intensity of rain over any 24-hour period during the flow monitoring period. WWF in the model was developed by selecting unit hydrograph parameters that replicate the flow monitoring results observed at each flow monitor. The unit hydrograph parameters were then adjusted until the modeled wet weather hydrograph achieved the verification criteria outlined in Table 6-5 when compared with observed flow monitoring results. A detailed description of the method of developing unit hydrographs to predict wet weather flow response in the collection system is provided in Chapter 5.

**Table 6-5: Wet Weather Flow Verification Criteria**

Parameter	Criteria
Shape	The shape of the modeled hydrograph should visually align with the shape of the observed hydrograph.
Timing	Modeled peaks and troughs should be similar to the observed peaks and troughs.
Flooding	Predicted flooding locations align with field observations or historical records
Peak Flow	-15% to +25% of observed peak flow
Flow Volume	-10% to +20% of observed peak volume

Catchments were established in the model using the Thiessen Polygon tool within SewerGEMS, which creates a catchment around each manhole within the City's collection system such that any point within the catchment is closer to the catchment's manhole than any other manhole within the system. Parameters were selected for the fraction of rainfall entering the sewer system as RDII (R), the time to peak (T) and the ratio of recession to the time to peak (K) for fast, medium, and slow RDII responses.

RTK parameters were assigned such that the R, T, and K values were the same for all catchments within a basin. These parameters were finalized by iterating through typical values for R, T, and K and observing the impact on the modeled hydrograph relative to the observed hydrograph. Modeled results were presented to City engineering and operation staff. The Brookside Basin (measured by FM1) showed flooding in upper portions of the basin collection system that was not consistent with operational experience. Historically, RDII has been an issue in the lower portions of the system near the Brookside Pump Station, indicating that the WWF response may not be homogenous across the entire basin. Johnson Creek borders the northern portion of the Brookside Basin, likely contributing to greater RDII within the northern portion of the basin as elevated surface water elevations may cause elevated groundwater elevations above the inverts of the deeper sewers near the pump station. Catchments adjacent to the creek were adjusted to higher R values to reflect a greater amount of RDII. Similarly, the remaining catchments were updated to lower their R values to reflect the lower RDII expected. This change allowed the final hydrograph to meet the flow verification criteria while eliminating the flooding within the model. Future flow monitoring and water level monitoring in the Brookside basin is necessary to confirm the varying volume of RDII across the basin.

The final wet weather calibration results are presented in Table 6-6. A sample calibration hydrograph is included as Figure 6-7.

**Table 6-6: Wet Weather Flow Verification Results**

	FM1	FM2	FM3	FM4	FM5	FM6
Visually Aligned	Yes	Yes	Yes	Yes	Yes	Yes
Timing of Peaks and Troughs Aligned	Yes	Yes	Yes	Yes	Yes	Yes
Flooding Align with Observations	Yes	Yes	Yes	Yes	Yes	Yes
Peak Flow (% of Observed)	-2.6%	+2.3%	-1.7%	-1.7%	+1.7%	-4.0%
Flow Volume (% of Observed)	-6.9%	-4.6%	-1.1%	+4.3%	+1.0%	+1.0%

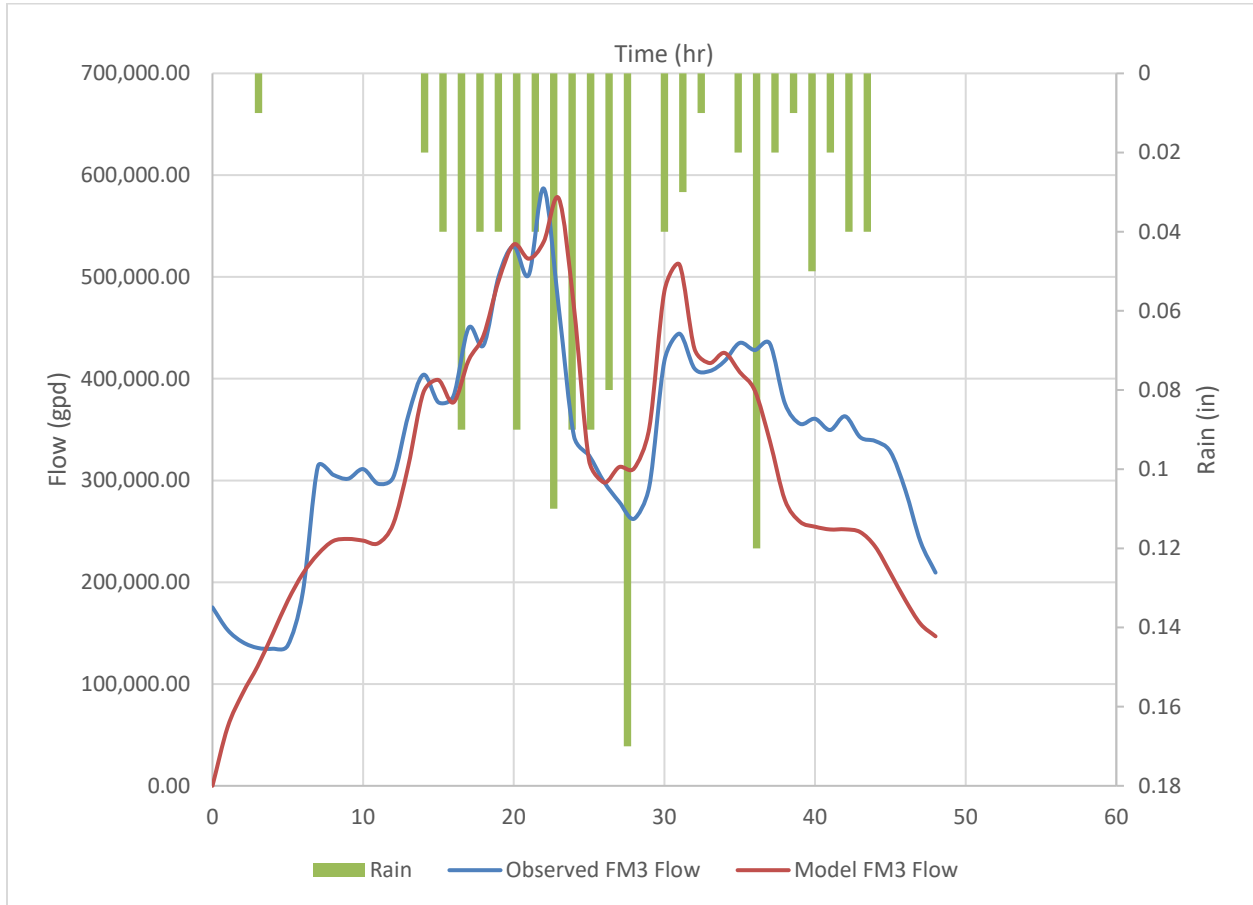


Figure 6-7: Wet Weather Hydrograph at FM 3 During January 27-28 Storm

## CHAPTER 7

# Hydraulic Capacity

The purpose of this chapter is to identify capacity deficiencies within the City’s collection system by analyzing the results of the City’s hydraulic model. This chapter includes evaluation criteria used to determine capacity deficiencies, an evaluation of the collection system’s hydraulic capacity under existing and future projected loading, and recommendations for addressing capacity deficiencies within the 20-year planning horizon of this WWSMP. This chapter also discusses the RDII within the City’s collection system and provides recommendations to address RDII for compliance with Clackamas WES reduction targets.

## 7.1 Capacity Evaluation Criteria

In July of 2020 the City and WSC conducted a hydraulic model review and evaluation criteria workshop. Potential criteria were evaluated in the workshop for determining hydraulic capacity deficiencies within the collection system. The final evaluation criteria are presented in Table 7-1. Any manhole and related pipeline in violation of these criteria is deemed hydraulically deficient. New infrastructure installed to address these deficiencies must meet these evaluation criteria as well as comply with the City’s design standards for sewer collection systems.

---

### IN THIS SECTION

Capacity Evaluation  
Criteria

Capacity Deficiency

WES RDII Reduction  
Program

Project

Recommendations

---

**Table 7-1: Hydraulic Capacity Evaluation Criteria**

Category	Evaluation Criteria
Model Peak Wet Weather Flow (WWF)	Peak WWF for purposes of evaluating system capacity will be based on the 10-year, 24-hour design storm timed to match peak RDII with daily diurnal peak dry weather flow.
Available Freeboard (>10 feet deep manholes)	Minimum 8-ft freeboard during Peak WWF. Freeboard measured as distance between manhole rim elevation and the maximum water surface elevation.
Allowable Surcharge ( $\leq$ 10 feet deep manholes)	2-ft allowable surcharge during Peak WWF. Surcharge measured as the maximum water surface elevation above the outflowing pipe soffit elevation.
Pump station firm capacity	Pump station capacity is equal to, or greater than, Peak WWF with largest pump out of service.

The City's evaluation criteria are consistent with the Oregon DEQ regulations. DEQ may withhold enforcement action for an SSO that occurs during larger storm events, which are defined as a 10-year, 24-hour duration storm for summer months and a 5-year, 24-hour duration storm for winter months. To be conservative, the City has elected to model the collection system capacity using a 10-year, 24-hour duration storm and not permit any sanitary sewer overflows (SSO). The manhole freeboard and surcharge limits selected in the design criteria are considered conservative and will identify any manholes at risk of an SSO under these storm conditions. Similarly, pump stations are to be evaluated based on their firm capacity (defined as the capacity of the station with the largest pump out of service).

## 7.2 Capacity Deficiency

The hydraulic model described in Chapter 6 was used to evaluate the City's collection system under dry and wet weather conditions. Loading was applied for existing and future conditions in accordance with the flows and loads outlined in Chapter 5. The following subsections describe deficiencies as defined by the evaluation criteria presented in the previous Section (7.1).

### 7.2.1 Existing Loading Conditions

The collection system was first modeled under the City's existing conditions. The results of the model are shown in Figure 7-1. The model did not identify any SSOs under existing wet weather conditions. Sixteen (16) manholes were found to not meet the freeboard or surcharge criteria. These manholes and the amount of surcharge/freeboard for each manhole are shown in Table 7-2.

**Table 7-2: Existing Manholes Not Meeting Primary Evaluation Criteria**

Manhole ID	Manhole Depth (feet)	Modeled Depth of Surchage (feet)	Freeboard (feet)
1002	10.75	4.46	6.29
1115	10.75	4.46	6.29
1433	7.40	2.55	4.85
1434	6.80	3.47	3.33
1435	6.40	3.90	2.50
1436	9.47	4.65	4.82
1437	9.40	4.66	4.74
1438	9.50	4.68	4.82
1439	6.60	3.24	3.36
1440	6.50	3.24	3.26
1503	9.00	2.91	6.09
1510	6.00	3.38	2.62
1511	6.00	2.47	3.53
1515	3.70	2.24	1.46
1708	10.00	2.04	7.96
1710	10.20	2.33	7.87

Each pump station was evaluated to determine whether its firm capacity was greater than the peak WWF. All of the City's pump stations are designed using a lead-lag pump configuration. Under this configuration, the lead pump handles all flow until the pump can no longer keep up with incoming flow, at which point the water surface level in the wet well rises to trigger a setpoint that calls the lag pump to turn on in parallel with the lead pump. The firm capacity is defined as the pump station's capacity with the largest pump out of service. The results of the pump station analysis are shown in Table 7-3.

**Table 7-3: Pump Station Results Under Existing Loading**

Pump Station	Firm Capacity with Largest Pump Out of Service (gpm)	Peak Wet Weather Flow (gpm)	Meets Design Criteria?
Island Pump Station (S1)	215 <sup>1</sup>	172	Yes
Harrison Pump Station (S2)	100 <sup>1</sup>	7	Yes
Home and Monroe Pump Station (S3)	400 <sup>1</sup>	163	Yes
Brookside Pump Station (S5)	550 <sup>1</sup>	1,193	No
55 <sup>th</sup> Avenue Pump Station (S6)	159 <sup>2</sup>	191	No

gpm = gallons per minute  
<sup>1</sup> Firm capacity taken from 2010 Wastewater System Master Plan  
<sup>2</sup> Firm capacity taken from Operations and Maintenance Manual



## 7.2.2 Sewers Under 2040 Loading

The collection system was also modeled at the end of the 20-year planning window for the year 2040. The results of the model output that indicate hydraulic deficiencies are shown in Figure 7-2. The model did not identify any sanitary sewer overflows under 2040 wet weather conditions. Thirty (30) manholes were found to not meet the surcharge or freeboard criteria. The manholes with hydraulic deficiencies and the amount of surcharge/freeboard for each manhole are shown in Table 7-5 (see next page).

Additionally, each pump station was evaluated against the design criteria from Section 7.1 assuming no upgrades to the existing infrastructure. The results are presented in Table 7-4.

**Table 7-4: Pump Station Results Under 2040 Loading**

Pump Station	Firm Capacity (gpm)	Peak Wet Weather Flow (gpm)	Meets Design Criteria?
Island Pump Station (S1)	215 <sup>1</sup>	172	Yes
Harrison Pump Station (S2)	100 <sup>1</sup>	7	Yes
Home and Monroe Pump Station (S3)	400 <sup>1</sup>	187	Yes
Brookside Pump Station (S5)	550 <sup>1</sup>	1,226	No
55 <sup>th</sup> Avenue Pump Station (S6)	159 <sup>2</sup>	191	No
gpm = gallons per minute			
<sup>1</sup> Firm capacity taken from 2010 Wastewater System Master Plan			
<sup>2</sup> Firm capacity taken from Operations and Maintenance Manual			

The peak WWF for the Island PS (S1), Harrison PS (S2), and 55<sup>th</sup> Avenue PS (S6) did not increase from the existing conditions. Through inspection of the modeling results, the contributing sewersheds for these pump stations are currently built-out and are not anticipated to experience additional densification as described in Chapter 5.

**Table 7-5: 2040 Manholes Not Meeting Primary Evaluation Criteria**

Manhole ID	Manhole Depth (ft)	Modeled Depth of Surchage (ft)	Freeboard (ft)
1002	10.75	4.72	6.03
1015	10.58	3.15	7.43
1115	10.75	4.72	6.03
1432	8.60	2.01	6.59
1433	7.40	3.39	4.01
1434	6.80	4.58	2.22
1435	6.40	5.08	1.32
1436	9.47	6.14	3.33
1437	9.40	6.16	3.24
1438	9.50	6.29	3.21
1439	6.60	4.87	1.73
1440	6.50	4.87	1.63
1441	5.60	3.55	2.05
1442	7.80	2.95	4.85
1443	7.70	2.45	5.25
1497	3.80	2.73	1.07
1502	6.08	2.99	3.09
1503	9.00	4.65	4.35
1510	6.00	4.56	1.44
1511	6.00	3.65	2.35
1512	5.90	3.06	2.84
1513	5.80	2.42	3.38
1515	3.70	3.42	0.28
1708	10.00	3.96	6.04
1709	9.30	2.89	6.41
1710	10.20	4.20	6.00
1717	11.20	4.47	6.73
1718	11.80	4.99	6.81
1725	8.00	3.46	4.54
1726	5.00	2.74	2.26

### 7.2.3 Sewers Under Buildout Loading

The collection system was modeled at buildout conditions. The results of the model output that indicate hydraulic deficiencies are shown in Figure 7-3. The model identified one SSO location under design storm conditions (Manhole ID 1515). Thirty (30) manholes were found to not meet the freeboard criteria. These manholes and the amount of freeboard for each manhole are shown in Table 7-6.

**Table 7-6: Buildout Manholes Not Meeting Primary Evaluation Criteria**

Manhole ID	Manhole Depth (ft)	Modeled Depth of Surchage (ft)	Freeboard (ft)
1002	10.75	4.83	5.92
1015	10.58	3.47	7.11
1115	10.75	4.83	5.92
1432	8.60	2.24	6.36
1433	7.40	3.73	3.67
1434	6.80	5.02	1.78
1435	6.40	5.55	0.85
1436	9.47	6.74	2.73
1437	9.40	6.76	2.64
1438	9.50	6.94	2.56
1439	6.60	5.53	1.07
1440	6.50	5.53	0.97
1441	5.60	4.21	1.39
1442	7.80	3.62	4.18
1443	7.70	3.12	4.58
1497	3.80	3.39	0.41
1502	6.08	3.69	2.39
1503	9.00	5.35	3.65
1510	6.00	5.03	0.97
1511	6.00	4.12	1.88
1512	5.90	3.53	2.37
1513	5.80	2.89	2.91
1515	3.70	3.70	0
1708	10.00	4.59	5.41
1709	9.30	3.52	5.78
1710	10.20	4.81	5.39
1717	11.20	5.21	5.99
1718	11.80	5.73	6.07
1725	8.00	4.21	3.79
1726	5.00	3.49	1.51

**Table 7-7: Pump Station Results Under Buildout Loading**

Pump Station	Firm Capacity (gpm)	Peak Wet Weather Flow (gpm)	Meets Design Criteria?
Island Pump Station (S1)	215 <sup>1</sup>	172	Yes
Harrison Pump Station (S2)	100 <sup>1</sup>	7	Yes
Home and Monroe Pump Station (S3)	400 <sup>1</sup>	194	Yes
Brookside Pump Station (S5)	550 <sup>1</sup>	1,239	No
55 <sup>th</sup> Avenue Pump Station (S6)	159 <sup>2</sup>	191	No
gpm = gallons per minute			
<sup>1</sup> Firm capacity taken from 2010 Wastewater System Master Plan			
<sup>2</sup> Firm capacity taken from Operations and Maintenance Manual			

Similar to the 2040 scenario, there was no observed increase in the model peak WWF into the Island PS (S1), Harrison PS (S2) or 55<sup>th</sup> Avenue PS (S6) between the existing and buildout scenarios. Each station's respective sewershed is currently built out and does not include properties or land use categories with potential for densification.

#### 7.2.4 Recommended Capacity Improvements

The following subsections recommend capacity improvements for gravity pipelines and pump stations based on the results in the previous sections.

##### 7.2.4.1 Gravity Pipelines

As discussed in the previous sections, 30 manholes are anticipated to have insufficient freeboard under 2040 and buildout conditions. Under buildout loading, a SSO is predicted in manhole 1515 and manhole 1497 is within 6 inches of overflowing. Both of these manholes are at or near the upstream end of the piping run. The surcharging issue is a result of backwater from capacity deficiencies downstream. To address these hydraulic deficiencies, WSC recommends the City collect additional information prior to initiating a capital upsizing project.

A topographical survey is recommended prior to implementing any capacity improvements. The City's data set for building the model was limited to manhole depths measured by hand from the manhole rim to the middle of the invert channel. To build the model, LIDAR data was used to approximate rim elevations and, in turn, invert elevations, which introduces potential error as discussed in Chapter 6. A topographical survey recording the rim elevations and the invert elevations for each of these 30 manholes identified in Table 7-6 is recommended to improve the accuracy of the pipe slopes in the model and confirm the existence of a hydraulic deficiency.

Although capacity deficiencies have been identified, the City would prefer to defer any improvement projects until further investigation confirms that capacity deficiencies are creating the surcharging predicted in the model. Field crews have not seen issues in this part of the system. Additional flow monitoring is recommended as part of an overall RDII reduction strategy in Section 7.3, and field locations for flow monitors within the Brookside basin could be selected to create smaller catchments with specific wet weather response characteristics verified against the flow data. An additional level monitor could be temporarily placed in MH 1515 to collect data on water levels to see if backwater conditions caused by capacity constraints downstream are truly producing the manhole surcharging predicted by the hydraulic model. Several manufacturers provide level monitoring instrumentation designed for safe operation within sanitary sewers that can capture and transmit level data to a cloud-based server for monitoring by City operations. Surveying inverts and breaking the basin into smaller catchments to verify the hydraulic model against collected field data would confirm the need for the capacity upgrade project.



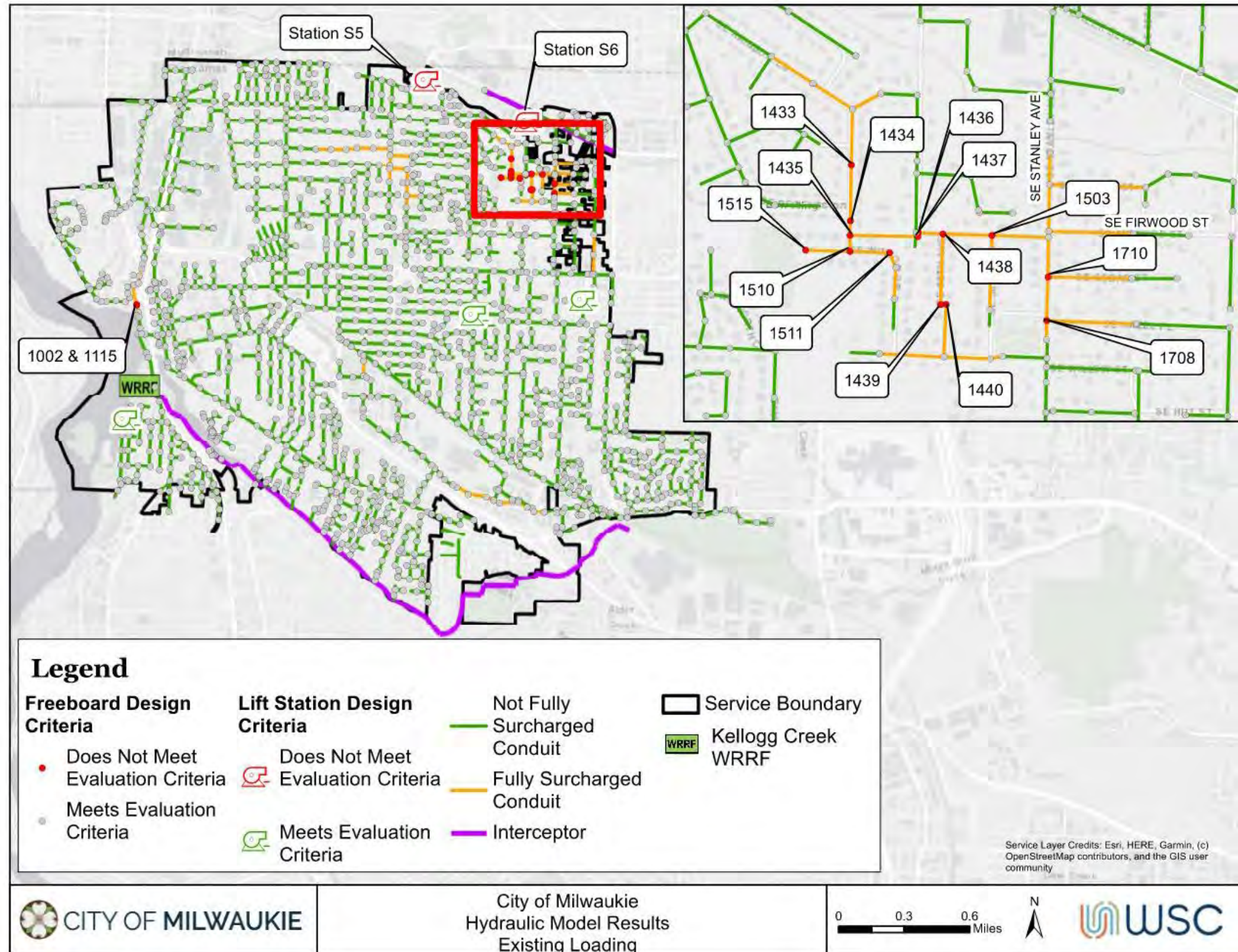


Figure 7-1: Hydraulic Capacity Evaluation Results Under Existing Loading



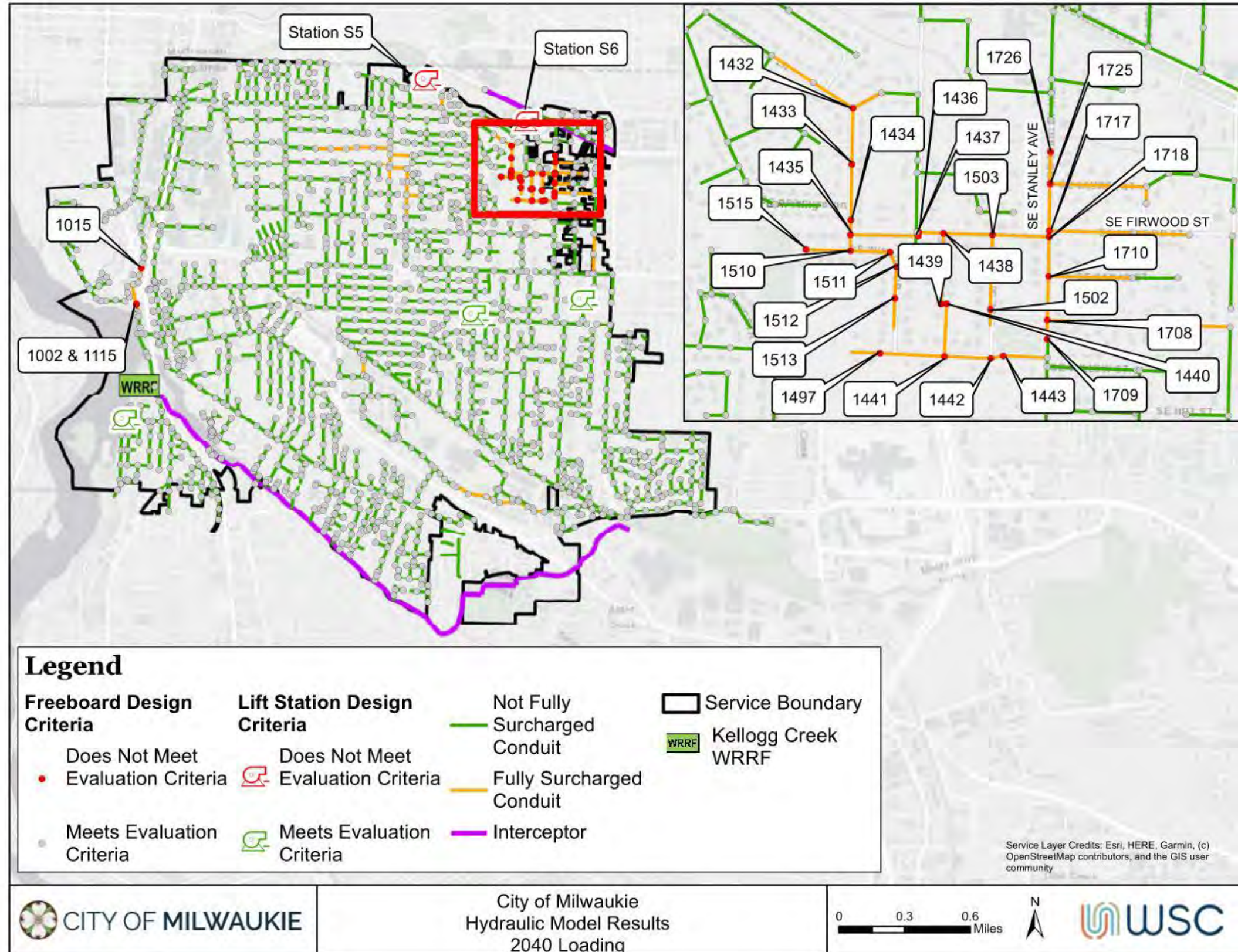


Figure 7-2: Hydraulic Capacity Evaluation Results Under 2040 Loading



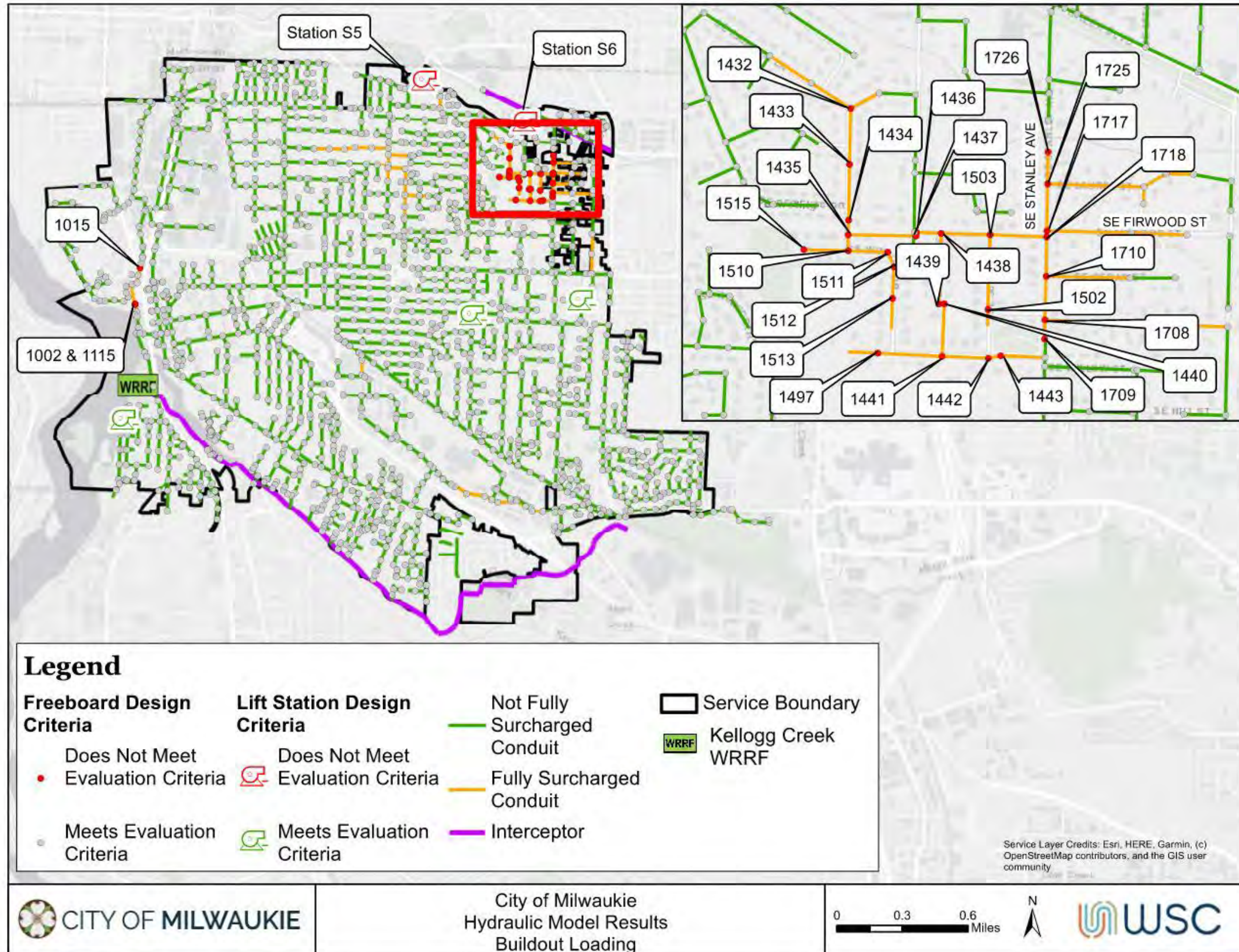


Figure 7-3: Hydraulic Capacity Evaluation Results Under Buildout Loading

Most of the capacity constrained manholes are located in the Brookside Basin. Assuming the manhole survey and additional flow monitoring confirms these Brookside Basin manholes are deficient and that upsizing of capacity is required, the next phase of work will be to upsize pipes adjacent to the at-risk manholes to improve the capacity of the system. WSC recommends the pipes in Table 7-8 be upsized to improve capacity within the Brookside Basin. These pipelines are shown visually in Figure 7-4. The resulting hydraulic improvements for the impacted manholes are shown in Table 7-9. Buildout conditions were used in this analysis to design the ultimate required pipe sizing, so the improvements address deficiencies through buildout.

**Table 7-8: Pipeline Capacity Upgrades**

Upstream Manhole	Downstream Manhole	Existing Size (inches)	Upgraded Size (inches)	Length (feet)
1435	1434	8	10	77
1432	1431	8	10	250
1434	1433	8	10	298
1433	1432	8	10	298
1436	1435	8	10	361
<b>Total Linear Footage of Upsizing for Project</b>				<b>1,284</b>

Table 7-9: Brookside Manhole Hydraulic Improvements (2040 Loading)

Manhole ID	Manhole Depth (feet)	Depth of Surcharge (feet)	Freeboard (feet)
1432	8.60	0.52	8.08
1433	7.40	0.56	6.84
1434	6.80	0.54	6.26
1435	6.40	0.68	5.72
1436	9.47	0.52	8.95
1437	9.40	0.47	8.93
1438	9.50	0.72	8.78
1439	6.60	0.27	6.33
1440	6.50	0.38	6.12
1441	5.60	0.27	5.33
1442	7.80	0.30	7.50
1443	7.70	0.24	7.46
1497	3.80	0.09	3.71
1502	6.08	0.07	6.01
1503	9.00	0.44	8.56
1510	6.00	0.16	5.84
1511	6.00	0.08	5.92
1512	5.90	0.07	5.83
1513	5.80	0.07	5.73
1515	3.70	0.07	3.63
1708	10.00	0.47	9.53
1709	9.30	0.02	9.28
1710	10.20	0.46	9.74
1717	11.20	0.75	10.45
1718	11.80	1.27	10.53
1725	8.00	0.2	7.80
1726	5.00	0.09	4.91



The remaining two capacity constrained manholes (MH 1002 and MH 1015) are located along the siphon that crosses Johnson Creek in multiple locations. Invert and rim elevations for the siphon are available from the record drawings for these pipelines. However, the invert and rim elevations for the manholes upstream of the siphon were approximated using LIDAR data and adjustments made to provide for continuity of the pipelines, as discussed in Chapter 6. The upstream MH 1015 is located off the paved roadway in an undeveloped area along the north bank of Johnson Creek near the SE 17<sup>th</sup> Ave bridge. MH 1002 is located in an undeveloped area with dense vegetation and mature tree cover. There may be a higher likelihood for error in calculating manhole rim elevations using LIDAR for both these manholes outside of the paved roadway. A topographic survey is recommended to confirm the manhole inverts and rim elevations, along with a study of appropriate measures to reduce the risk of a SSO at each manhole. As most of the manholes along this section of sewer and siphon do not appear to be deficient, and the two deficient manholes appear to provide over 5 feet of freeboard under buildout peak WWF, an upsizing of the pipe to increase capacity is not justified. Retrofitting the manholes with bolt-down watertight covers will likely be a sufficient corrective action and aligns with recommendations in Chapter 9 to mitigate the risk of flooding along Johnson Creek induced by climate change.

#### 7.2.4.2 Sewer Pump Stations

Under all three loading scenarios, the peak WWF exceeds the firm capacity of the Brookside PS (S5) and the 55<sup>th</sup> Avenue PS (S6). Both stations may require upsizing of pumps, motors, and associated equipment to increase the firm capacity above the predicted buildout peak WWF. The Brookside PS (S5) does have a passive overflow in the wet well that discharges to the City of Portland Lents Trunk and could minimize the risk of an SSO in the station until pump capacity is increased.

There are discrepancies within the documentation for pump station S6 that require further investigation. The operations and maintenance manual states that while the firm capacity of the pump station was designed to be 159 gpm, the actual firm capacity is 310 gpm due to lower than anticipated head losses in the pump station and force main piping. (19) The lower value of 159 gpm has been included in this document as the firm capacity and is calculated to be 32 gpm below the peak WWF into the station. City confirmation of the pumping rates at S6 is recommended to confirm that the pumps are operating above the peak WWF at buildout of 191 gpm. No pump upsizing project is recommended to address the potential capacity deficiency, however Chapter 9 has identified a full pump station replacement to address seismic risks and any pump deficiencies could be included within that project. The risk of a SSO appears to be very low for this station as even at the lower pumping rate, a single pump would be capable of handling 191 gpm with a 2-foot rise in the water level within the wet well. Since there are no identified deficiencies for manholes in the catchment for Pump Station S6 there would be sufficient freeboard to accommodate higher water levels in the wet well without an overflow.

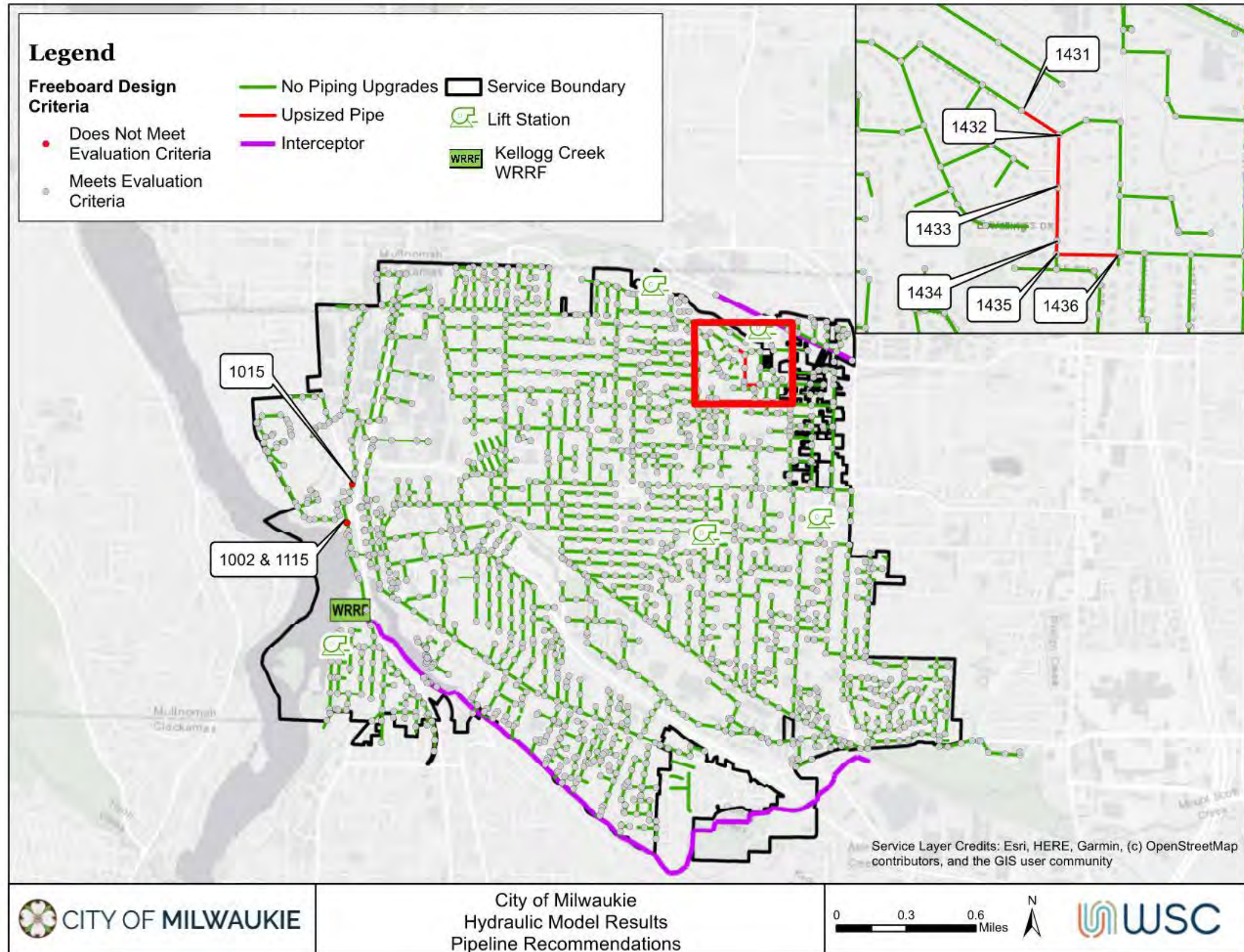


Figure 7-4: Recommended Pipeline Projects



Pump station S5 was identified as being undersized for peak WWF under all three loading scenarios. The anticipated peak WWF at buildout is more than double the firm capacity the pump station was designed for. The station was rebuilt in 2000, indicating that the pumps are likely close to the end of their useful life. WSC recommends the pumps, motors, and associated equipment be upsized to provide a firm capacity that exceeds the buildout peak WWF. At peak WWF the velocity in the force main will be approximately 9 feet per second which exceeds the acceptable range of 3 to 5 fps in the City's standards. Industry standards often allow for higher velocities of up to 8 to 10 fps within force mains, so it may be possible to use variable frequency drives with new pumps so that force main velocities are kept within the range identified in City standards for the majority of operating conditions and only exceeding these values during short periods of peak WWF. Upsizing of the force main is not recommended at this time.

### 7.3 Clackamas WES RDII Reduction Program

Clackamas WES has identified the reduction of RDII as a priority within the collection systems that convey wastewater to the Kellogg Creek and Tri-City WRRFs. This section provides an overview of the Clackamas WES RDII reduction program and the impact on the City for meeting reduction targets.

#### 7.3.1 Program Overview

Clackamas WES has launched a RDII reduction program stemming from the findings presented in their SSSMP. WES performed a cost-benefit analysis to determine the optimal balance of RDII reduction versus treatment and conveyance infrastructure expansion to handle future flows. The study concluded that a 65% reduction in RDII would result in the lowest life cycle cost for its ratepayers and member agencies. As a result, WES is working with partner jurisdictions to cooperate in reducing RDII.

The City's collection system consists of two Clackamas WES basins – the Milwaukie Basin and the Harmony Basin (Figure 7-5). Target levels of RDII have been established for both basins, with the Milwaukie Basin identified as one of 19 high-priority basins across the WES system. To achieve the most cost-effective plan, high priority basins must achieve target reductions to RDII by 2040. The lower priority basins must achieve target reductions by estimated buildout in 2087. (20) WES anticipates that all problematic pipelines will need to be rehabilitated or replaced and entire laterals will need to be rehabilitated or replaced from the mainline to the home, including both the public and private portions of the service laterals, to realize a 65% reduction in RDII. The projected 2040 RDII rates and the target reductions for the City of Milwaukie basins are provided in Table 7-10. Although the WES SSSMP projects RDII rates through buildout, the long-term reduction of RDII beyond 2040 goes beyond the planning horizon for this document.

**Table 7-10: RDII Reduction Targets Under Clackamas WES Program**

Clackamas WES Basin	Projected RDII by 2040 (gpad)	RDII Target Value by 2040 (gpad)
Milwaukie	17,100	5,985
Harmony	14,100	Not applicable
gpad = gallons per acre per day      RDII = rainfall dependent infiltration and inflow		

WES calculated existing RDII rates using flow data collected from permanent flow meters associated with each basin in 2015 and applying an estimated degradation rate to these values to project future RDII. The degradation curve was synthesized using data for pipe condition and age across WES' collection system. The degradation of condition scores as a pipe ages, as a percentage, was then applied to the existing RDII to approximate the increase in RDII volume over time. The 2016 RDII rate observed from flow monitoring results as well as the projected future RDII rates using the degradation curve from the WES SSSMP are provided in Table 7-11.

**Table 7-11. WES Calculated RDII and Projected Future Rates for City of Milwaukie**

WES Basin	Rainfall Dependent Infiltration and Inflow Rate (gallons per day per acre)						
	2016	2020	2025	2030	2035	2040	Buildout
Milwaukie	6,300	8,400	10,600	12,800	15,000	17,100	37,600
Harmony	3,200	5,400	7,600	9,700	11,900	14,100	34,500

WES is in the process of developing a grant program to assist its partner agencies in achieving the target RDII reductions. As of January 2021, the proposed grant funding would cover 33% of costs on all RDII projects undertaken by the partner agencies within the priority basins. Grant funding could cover expenses relating to flow monitoring studies, consultant services to analyze flow monitoring results, RDII source identification, rehabilitation design and construction, and post flow monitoring services. The funding process is still under development, but it is envisioned to include the submittal of a proposal to WES that complies with a set of program guidelines. All approved proposals submitted prior to February 1<sup>st</sup> would be eligible for funding in the following fiscal year.



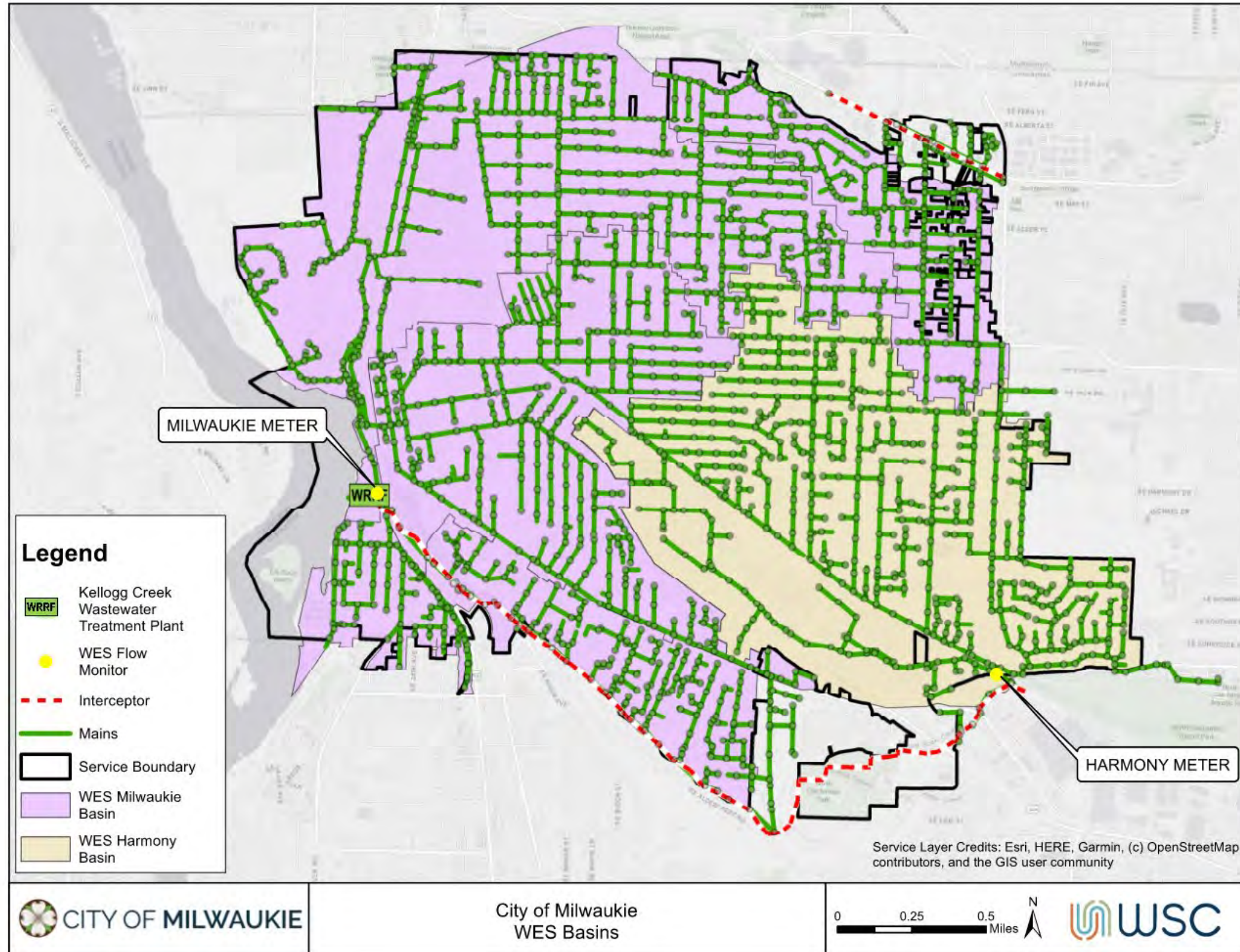


Figure 7-5: WES Basins within the City

### 7.3.2 Existing RDII

The City's existing collection system was evaluated for RDII by calibrating the hydraulic model to WWF monitoring data and then running the model under design storm conditions. Additional information on the flow monitoring and selection of the design storm is provided in Chapter 5 while additional information on the hydraulic model and its calibration is provided in Chapter 6. To provide a meaningful comparison with the WES target values and projected future flows presented in Section 7.3.1, the RDII was evaluated using the same November 22, 2011 storm rainfall used for identifying deficiencies in the WES SSSMP. The calibrated model results were analyzed at the locations of the permanent WES Milwaukie and Harmony meters to allow comparison with the WES target values. Model results were also analyzed at each of the flow monitoring locations described in Chapter 5 to determine the relative contribution of RDII within each subbasin. The results for the City's monitoring locations are provided in Table 7-12.

**Table 7-12: Existing Peak RDII**

Flow Meter	Sewer Basin	ADWF (gpd)	Peak WWF (gpd)	Ratio WWF to ADWF	RDII (gpd)	Contributing Acreage <sup>1</sup>	RDII Rate (gpad)
Milwaukie	Milwaukie (WES basin)	1,216,096	6,424,396	5.3	5,554,351	1,213	4,580
1	Brookside	160,692	1,223,781	7.6	1,046,177	155	6,752
2	North Milwaukie & Brookside	473,111	3,346,598	8.2	3,346,598	641	5,218
3	Mid Milwaukie	199,527	1,218,922	6.4	1,064,976	365	2,921
4	South Milwaukie	57,013	591,983	10.4	538,732	77	7,019
Harmony	Harmony (WES basin)	863,304	2,827,751	3.3	1,969,800	556	3,542
5	Harmony – West	441,715	2,002,907	4.5	1,497,661	158	9,438
6	Harmony - East	203,265	567,939	2.8	356,683	261	1,367

Gpd = gallons per day    gpad = gallons per acre per day    ADWF = average dry weather flow    WWF = wet weather flow  
RDII = rainfall derived infiltration and inflow  
<sup>1</sup>. The contributing acreage represents a buffer area within 100 feet of each sewer main.

Currently, the modeled RDII rate at the Milwaukie Meter is below the 2040 target rate of 5,985 gpad identified by WES. The current RDII rate of 4,580 gpad calculated from 2020 flow monitoring data also is lower than the 6,300 gpad calculated by WES for the same basin in 2016 and the 8,400 gpad projected for 2020 in the WES SSSMP. Based on these comparisons, the RDII within the Milwaukie basin does not appear to be degrading at the assumed projections in the WES SSSMP. One likely factor could be that the City has completed structural sewer repairs within the basin since 2016 to replace aging vitrified clay pipe which would likely reduce the volume of RDII entering the system.



Although the total RDII rates for the Milwaukie and Harmony meters are below the WES RDII Reduction Program targets for 2040, there appears to be relatively higher rates of RDII within the Harmony – West, Brookside, North and South Milwaukie sub-basins. Another common method for evaluating RDII is to analyze the ratio of peak WWF to ADWF, or “peaking factor”, within the system. In the 2012 IGA between Clackamas WES and the City, a peaking factor of 4:1 is stated as the target for the Kellogg Creek WRRF. The modeled flows at the Milwaukie Meter exceed this ratio while the Harmony Meter does not. The Brookside, North and South Milwaukie basins appear to be a higher priority for continued structural condition repairs to continue to maintain RDII rates at the Milwaukie Meter below the 2040 target and to potentially lower the peaking factor to meet IGA conditions.

### 7.3.3 Future RDII

The hydraulic model was used to evaluate future RDII to understand the impact of RDII on the collection system and at the Kellogg Creek WRRF with respect to WES’ goals. Without using any estimates for degradation rates, the projected RDII within both the Milwaukie and Harmony basins are nearly identical to existing rates. Although degradation rates could be applied to estimate future RDII if no system repairs were made, the City condition data provided to WSC may not be conducive to a meaningful statistical analysis. Detailed information on pipe repairs would need to be compared to historic condition data to develop and plot the relationship between condition defect scoring and the time to failure (or repair). Furthermore, any projection of future RDII based on degradation may not reflect the actual conditions, as demonstrated by comparing the 2020 flow monitoring results to the previous WES projections from 2015. Ongoing repairs to structural deficiencies within the collection system will likely offset increased RDII caused by degradation.

### 7.3.4 RDII Reduction

WSC recommends the City conduct flow monitoring on a five-year cycle to determine if ongoing structural condition repairs are offsetting the aging and degradation of the collection system to sufficiently maintain the RDII rate below WES target values. Flow monitoring conducted as part of this WWSMP appears to indicate a reduction in RDII as compared to projections within the WES SSSMP. Although WES has called for a 65% reduction in RDII by 2040 through rehabilitation of mains and both public and private service laterals, this may not be necessary. WSC recommends a less aggressive RDII reduction strategy to achieve WES’ desired outcome by focusing on addressing structural condition deficiencies as detected through the City’s on-going CCTV inspection program with periodic monitoring to determine if the RDII rate is consistently maintained below the WES target value.

At a minimum, flow monitoring should consist of deploying flow meters in the same locations as those identified and used in this WWSMP. Additional monitors could be placed in the Brookside, North Milwaukie, and South Milwaukie basins to better understand if there is a geographical distribution of RDII within those basins that could further prioritize rehabilitation efforts. The City should coordinate with WES to determine if cost sharing support for this effort is eligible under WES’ grant program.

To address RDII in the short term, the City should implement the condition-based improvements identified in Chapter 8. By addressing the Grade 5 and Grade 4 defects within the collection system, the City will reduce the number of pathways for RDII to enter the system through correcting the most severe types of defects. Although this approach does not always result in reduction of RDII system-wide, these repairs are necessary and can be followed by flow monitoring to assess the results. WSC recommends the City prioritize condition-based projects within the Brookside, North Milwaukie and South Milwaukie Basins. These basins have the largest rates of RDII that contribute to the Milwaukie Basin prioritized by WES for reductions by 2040.

## 7.4 Project Recommendations

Based on the analysis in Sections 7.2 and 7.3, WSC developed a list of capacity-based projects to address the hydraulic deficiencies within the City's collection system over the 20-year planning period. Each project is identified in Table 7-13. The concept of each project is explained in Sections 7.2.4 and 7.3.4. Costs for each project are provided in Chapter 10.

**Table 7-13: Capacity Based Projects**

Project Number	Capital Projects to Address Capacity Deficiencies <sup>1</sup>
CAP-1	Survey rim and invert elevations of the 30 manholes identified as capacity deficient in Section 7.2
CAP-2	Upsize 1,284 LF of sewer between MH 1432 and MH 1436 to 10-inch diameter PVC.
CAP-3	Conduct flow monitoring at the locations identified in this WWSMP every 5 years to monitor RDII levels within the collection system
CAP-4	Provide a pipe stub out to the right-of-way to Willamette Townhouse Apartments. This is carried over from the City's FY21-FY26 Capital Improvement Plan.
<sup>1</sup> Note that capacity deficiencies at Brookside (S5) and 55 <sup>th</sup> Ave (S6) pump stations are recommended for further analysis and potential corrective action as part of condition-based improvements as components reach the end of their useful life. These condition-based projects are described in Chapter 8.	



## CHAPTER 8

# Condition Evaluation

The purpose of this chapter is to review the available data to assess the current condition of the City’s wastewater collection system assets and identify condition-related deficiencies that will require corrective action within the planning period. Detailed condition assessment of pump stations and manholes was not included in the master plan effort. The following sections will include a review of existing City practices, identification of data gaps, a risk-based method for prioritizing pipe rehabilitation and replacement, recommendation for a renewal strategy and a list of specific projects to be completed within the 20-year planning horizon of this WWSMP.

## 8.1 Current Condition Assessment Practices

The City maintains a dedicated crew that performs cleaning and a CCTV inspection of each sewer main in the collection system on a four-year cycle. Defects identified within each main are recorded and assigned scores according to the NASSCO PACP standards. Each pipe is assigned a structural, maintenance, and overall score; a structural, maintenance, and overall quick score; and a likelihood of failure score in accordance with PACP standards. CCTV videos and PACP scoring data are stored within the GraniteNet software platform.

Sewer mains that require additional cleaning are placed on the City’s quarterly maintenance cycle where they are cleaned every three months. Reasons for the increased maintenance include routinely observed grease build up and heavy root intrusion. Quarterly maintenance activities consist of flushing or jetting the mains or applying Root-X to address excessive root

---

### IN THIS SECTION

Current Condition Assessment Practices

Existing Pipeline Condition Data

Existing Condition Deficiencies

Prioritization Methodology

Pump Stations

Renewal Strategy

---

buildup. The current locations of sewer mains requiring routine quarterly maintenance are shown in Figure 3-5 in Chapter 3.

The City currently conducts a visual inspection of manholes during the CCTV pipe inspections. Manholes with significant visible deficiencies are repaired by City maintenance crews. The City does not perform routine condition evaluations of their manholes using NASSCO's Manhole Assessment Certification Program (MACP), although City staff have been trained in MACP and the GraniteNet software platform is compatible with MACP scoring. There are a variety of costs associated with a MACP program that should be considered ranging from simple inspections occurring during CCTV inspection through specialized inspection tools and software. WSC recommends the City pilot some of these options as part of their ongoing rehabilitation work to determine the best option for them.

## 8.2 Existing Pipeline Condition Data

In June 2017, the City transitioned their sewer condition data collection and inspection software from Granite XP to GraniteNet. Prior to this transition, the City uploaded their CCTV videos to Granite XP and the videos were coded with a composite score that emulated a NASSCO PACP score but was not fully in accordance with the PACP scoring methodology. With the software transition, the CCTV videos are now uploaded to GraniteNet and coded with NASSCO PACP compliant scores. Unfortunately, when the Granite XP data was transferred into GraniteNet, all condition scoring information prior to the software conversion were not compatible with the new software. Previous CCTV videos are still available, but the condition scoring data is no longer accessible and was not available for use in this WWSMP.

At the time of this condition assessment work, the City has PACP scores available for 55 percent of mains within GraniteNet. The City is continuously conducting CCTV inspections on approximately one-quarter of the collection system each year and is anticipated to have PACP scoring for all collection system pipes by 2022. For the purposes of determining the condition-related deficiencies within the piping system for this WWSMP, the existing data is assumed to be a prorated representation of the entire system, and quantities of pipe deficiencies across the entire system can be estimated by assuming that the ratio of deficient pipe to the quantity of pipe length inspected. The locations of sewer mains for which PACP data was available at the time of the writing of this WWSMP are provided in Figure 8-1.

## 8.3 Existing Condition Deficiencies

To identify potential deficiencies within the existing collection system, PACP scoring data was overlaid onto GIS shape files for the system. For simplicity, the PACP overall quick score was used as an indicative metric for identifying pipes that may have structural deficiencies requiring corrective action. Each pipe defect is assigned a numeric grade from 1 to 5, where 5 represents the most significant defect that can be coded using the PACP system. Pipes with defects assigned a Grade 5 have either already failed or represent an imminent failure within the next five years and require immediate attention, while a Grade 4 defect represents severe defects and a high-risk of failure within the next 5 to 10 years. (21) Existing pipes that have PACP data indicating a defect of Grade 4 or 5 are provided in Figure 8-1. A list of what constitutes a Grade 5 and a Grade 4 defect is included in Appendix F. Further information on defect types can be found in the latest edition of NASSCO's PACP manual.

PACP coding was used to quantify the condition deficiencies by identifying the total linear footage of pipes with a defect of Grade 4 or higher. Approximately 10 percent of the pipes for which PACP scores are available have a defect of Grade 4 or higher, indicating that replacement within the next 10 years is recommended. A breakdown of the total linear footage of pipes and the percentage of total pipe provided in Table 8-1.

**Table 8-1: Existing System PACP Scoring Summary**

Worst PACP Defect Grade	Number of Pipes	Length of Pipes (LF of Pipe)	Percent of Total Pipe with PACP Scores on a Number of Pipe Basis (%)
5 (Multiple)	40	11,931	2
5 (Single)	46	12,879	2
4	105	28,251	6
3 or less	855	188,850	45
No Score	854	176,716	45
Total	1,900	418,627	100

Pipes with a single Grade 5 defect were separated from those with multiple Grade 5 defects to differentiate between pipes that may only require a spot repair versus those that may require a full pipe repair or replacement.

## 8.4 Prioritization Methodology

As the City continuously updates the database of PACP defect coding through the ongoing CCTV inspection program, and as the system continues to age, the list of pipes that require repair or replacement to address condition deficiencies will not remain static. A system for prioritizing sewer mains will allow the City to identify the top priority repairs or replacements during each budget planning cycle. The following sections describe a framework for using risk, defined by NASSCO's PACP Based Risk Management system as the product of consequence of failure (COF) and likelihood of failure (LOF), to prioritize mains for condition-based improvements within the City's collection system.



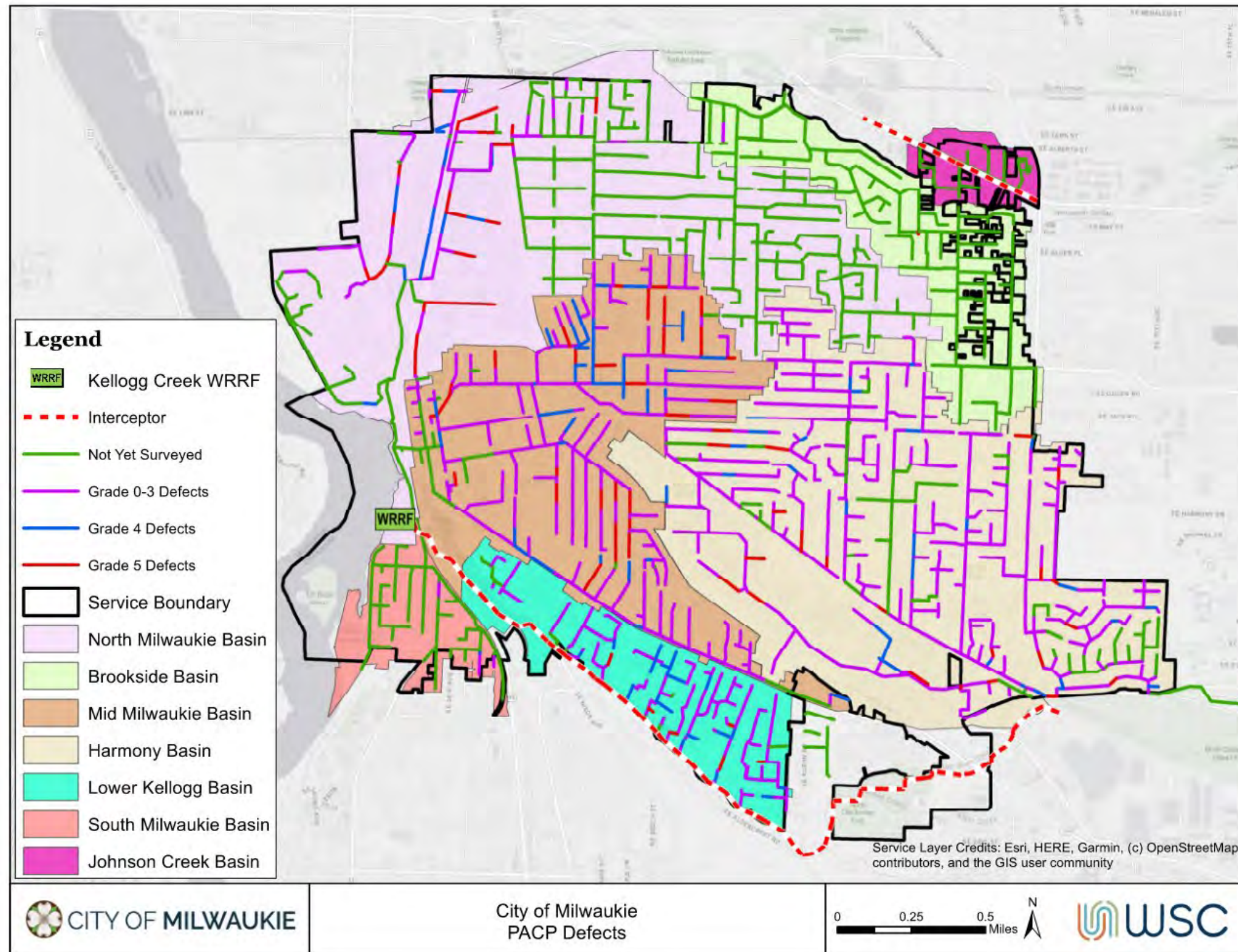


Figure 8-1: Mains with PACP Scores at Time of Analysis

### 8.4.1 Consequence of Failure

Under NASSCO’s PACP Based Risk Management system, COF is assigned on a scale of 1 to 6 and incorporates the economic, social, and environmental impact an asset would have if that asset were to fail. Prior to this assessment, the City used pipe size as the sole factor for determining COF and evaluated COF on a scale of 1 to 3. WSC updated the City’s existing COF factors to align with the triple bottom line (economic, social, and environmental) methodology in NASSCO’s PACP Based Risk Management System. WSC considered the following factors when developing COF values:

**Table 8-2: COF Evaluation Criteria**

Evaluation Criteria	Economic Cost	Social Cost	Environmental Cost
Pipe Diameter	X	X	X
Pipe Depth	X		
Road Type	X	X	
Seismic Backbone	X	X	
Impact on Water Bodies			X

Each main was assigned a score of 1 to 6 for each of these factors. The factors were then weighted and normalized to create a composite COF score.

#### 8.4.1.1 Pipe Diameter

Pipe diameter was the first factor included in the COF determination as it was the basis of the City’s existing COF parameter. Pipe diameter represents a relative measure of economic cost as the larger the main is, the greater the costs to the City for an unplanned replacement. If the pipe were to fail, the magnitude of environmental cleanup costs is likely to scale relative to the size of the pipe as a proxy for the potential volume of a resulting SSO. Larger pipes also present a greater risk of social impact as the extent of potential upstream service outages affected by a failure is proportional to the pipe size. COF scoring criteria for pipe diameter are shown in Table 8-3.

**Table 8-3: COF Score by Pipe Diameter**

COF	Pipe Diameter
1	Pipe Diameter < 8"
2	8" ≤ Pipe Diameter < 10"
3	10" ≤ Pipe Diameter < 15"
4	15" ≤ Pipe Diameter < 20"
5	20" ≤ Pipe Diameter < 24"
6	Pipe Diameter ≥ 24"

### 8.4.1.2 Pipe Depth

Like pipe diameter, pipe depth is an economic cost incorporated into COF. The depth of a pipe impacts the ability of the City's crews to address a main break in an unplanned emergency repair scenario. The deeper a main is, the more excavation, time, and effort is required to replace or repair the main. Additionally, City crews do not have the equipment required to excavate to depths greater than 10 feet below ground surface. Sewers with pipe inverts deeper than 10 feet below ground surface require hiring a contractor with the necessary equipment and present a greater cost and longer lead time to complete repairs. COF scoring criteria for pipe depth are shown in Table 8-4.

**Table 8-4: COF Score by Pipe Depth**

COF	Pipe Depth
1	Pipe Depth < 6'
2	6' ≤ Pipe Depth < 10'
3	10' ≤ Pipe Depth < 14'
4	14' ≤ Pipe Depth < 18'
5	18' ≤ Pipe Depth < 24'
6	Pipe Depth ≥ 24'

### 8.4.1.3 Road Type

The type of road in which a sewer is installed effects the economic and social impacts of an unplanned failure. Economically, the type of road above a pipe impacts the level of traffic control, permitting, and pavement restoration required to complete replacement or repair of the sewer main. Replacing a pipe under a local, residential street impacts far less people than a pipe under an arterial street or highway. COF scoring criteria for road type are shown in Table 8-5.

**Table 8-5: COF Score by Road Type**

COF	Road Type
1	Unpaved
2	Minor Local
3	Major Local
4	Collector
5	Arterial/Building/Pool
6	Highway/Waterway



#### 8.4.1.4 Seismic Backbone

The City's backbone system is identified in Chapter 9 as the portions of the collection system that are essential for maintaining service to critical facilities following a major earthquake. The failure of a backbone pipe will have significant economic and social consequence. As recommended in Chapter 9, when replacement of a backbone pipe is required within areas of higher risks of seismic ground movement, there is an opportunity to repair or replace with a more robust pipeline system including restrained joints and/or flexible pipe materials to resist ground deformations caused by an earthquake. Additional geotechnical studies and special pipe materials may be required for backbone pipe repairs and may not be possible in an unplanned emergency repair scenario. Thus, unplanned failures of backbone pipes represent a high COF and these pipes are differentiated from non-backbone pipes. COF scores for the seismic backbone are shown in Table 8-6.

**Table 8-6: COF Scores Based on Seismic Backbone**

COF	Impact on Seismic Backbone
1	Not Included in Seismic Backbone
6	Included in Seismic Backbone

#### 8.4.1.5 Impact on Water Bodies

The impact of a leak or break on a water body is considered an environmental cost. To assess the COF, each pipe was assigned a qualitative ranking for the level of impact a break would have on the closest water body. Distance to the water body was used as a proxy to estimate the level of impact. This likely overestimates the impact on water bodies as the water body is only impacted if a SSO can reach the water via overland flow. WSC did not evaluate potential spill paths for individual pipelines to determine if an SSO would reach the water body. COF scoring criteria for distances to water bodies are shown in Table 8-7.

**Table 8-7: COF Scores Based on Distance from Water Bodies**

COF	Impact on Water Bodies
1	Insignificant Impact (>150 LF From Water Body)
2	Minimal Impact (100 LF – 150LF From Water Body)
3	Minor Impact (75 LF – 100 LF From Water Body)
4	Moderate Impact (50 LF – 75 LF From Water Body)
5	Major Impact (25 LF – 50 LF From Water Body)
6	Significant Impact (Less than 25 LF From Water Body)

#### 8.4.1.6 Determination of Final COF Score

Once each main was assigned a COF score for each of the five categories, a weighted COF score was calculated using the weighting shown in Table 8-8. WSC chose to weight each COF category rather than assigning a weighting to the categories of economic, social, and environmental costs as NASSCO recommends. This allowed the City to better tailor the score weighting to their preferences.

The seismic backbone was given the largest weighting at 50 percent as these mains require the greatest amount of planning and design to repair to seismic standards and are essential for operating the system. A failure in a backbone main will impact the service to many of the City's customers and critical facilities. The impact to water bodies was weighted the lowest at 5 percent due to uncertainty of the true impacts that would be caused by individual pipe failures. The remainder of the categories were assigned a relative weighting in proportion to potential impacts to create a total weighting of 100 percent across all categories. Weighting percentages should not be considered static, and the City may identify the need to adjust to reflect changing priorities over time.

**Table 8-8: COF Score Weighting**

COF Category	Percentage of COF Score
Pipe Diameter	20%
Pipe Depth	10%
Road Type	15%
Impact on Water Bodies	5%
Impact on Seismic Backbone	50%
Total	100%

#### 8.4.2 Likelihood of Failure

The LOF factor is a calculated value that represents the probability a main will fail based on the main's physical condition. The LOF is typically determined by reviewing PACP scores, however as previously mentioned, the City did not have PACP scores available for all their mains. When PACP scores were available, the LOF was determined using the PACP scores. When PACP scores were not available, remaining useful life was used to estimate LOF. As the City continues to inspect mains and develop PACP scores, these scores can be used to update the LOF score in GIS for the mains that did not originally have PACP scores. This will allow the City to continue to refine the risk-based prioritization of their mains.

##### 8.4.2.1 PACP Based LOF

NASSCO's PACP Based Risk Management system determines LOF based on the main's PACP Quick Rating. A main's quick rating is a 4-digit code that is defined as follows:

- 1st digit – Highest grade defect identified in the PACP survey.
- 2nd digit – Frequency of occurrence for the highest-grade defect identified in the PACP survey. If the defect occurs more than 9 times, a letter is used to represent the frequency based on NASSCO's standards.
- 3rd digit – Second highest grade defect identified in the PACP survey.

- 4th digit – Frequency of occurrence for the second highest-grade defect identified in the PACP survey. If the defect occurs more than 9 times, a letter is used to represent the frequency based on NASSCO’s standards.

To determine LOF, the first two numbers of the main’s Overall Quick Rating are used. The scores are determined as follows:

- If the main has no defects (i.e., the Quick Rating is 0000), the LOF is assigned a value of 1.0.
- If the highest grade defect occurs no more than nine times, the LOF is the value of the first two numbers of the Quick Rating divided by 10. For example, a score of 4333 would have a score of  $43/10 = 4.3$ .
- If the second character is a letter, replace the letter with a zero, divide the first two numbers of the Quick Rating by 10 and add 1.0. For example, a score of 5B35 would have a score of  $(50/10) + 1 = 6.0$ .

#### 8.4.2.2 Non-PACP Based LOF

PACP scores were unavailable for 42% of the City’s mains at the time of this analysis. For the mains without a PACP score, an estimate of a main’s remaining useful life was used to estimate LOF. The estimated LOF scores were then used to develop a prioritized list for the remaining CCTV inspections. Based on the best available data from the City, the expected useful life of each main was estimated using the approximate age of installation and the pipe material. The remaining useful life was determined by subtracting a pipe’s age from its expected useful life.

The City’s collection system consists of a mix of clay, cast iron, ductile iron, steel, concrete, polyvinyl chloride (PVC) and high-density polyethylene (HDPE) pipe. For this assessment, an assumed useful life of 75 years was used for all gravity mains within the collection system. While the actual service life of an individual pipeline may vary, 75 years is a conservative estimate commonly accepted for these materials. Pipe age was missing in the City’s GIS system for most mains installed prior to 2007. To mitigate this data gap, pipe age was estimated by basin. The City’s 1994 SFP identified average installation dates for pipes by sewer basin, which are provided in Table 8-9. If the City’s GIS data lacked an installation date, the average installation date for its sewer basin was used in the remaining useful life calculation. LOF scores were assigned based on remaining useful life as shown in Table 8-10 below. For mains requiring quarterly maintenance, the LOF score was increased by one from the remaining useful life score to account for the increased risk of failure. Scores were capped at a maximum of six, regardless of if the main is on a quarterly maintenance program.

**Table 8-9: Installation Dates by Sewer Basin per 1994 SFP (1)**

Basin	Oldest Construction Date	Average Age
North Milwaukie	1954	1963
Mid Milwaukie	1926	1941
South Milwaukie	1972	1973
Lower Kellogg	1966	1974
Harmony	1954	1969
Brookside	1972	1972
Johnson Creek	1988	1988

**Table 8-10: LOF Based on Remaining Useful Life**

LOF	Remaining Useful Life
1	63-75 Years
2	50-62 Years
3	37-49 Years
4	24-36 Years
5	11-23 Years
6	Less than 11 Years

Note: If the main is on the City's Quarterly Maintenance List, the LOF was increased by 1, with the maximum allowable score being a 6.

### 8.4.3 Risk Prioritization

To help the City prioritize both repairs and future CCTV inspections, a risk score was calculated for each main by multiplying the main's COF by its LOF. For pipes that have been inspected and assigned a PACP score, the risk scores were prioritized into tiers using the breakdown shown in Table 8-11 and the risk scores ranged from 1 to 25. Risk prioritization tiers for each main are shown in Figure 8-2.

**Table 8-11: Risk Prioritization Tiers**

Risk Tier	Risk Score Range
Tier 1	Risk $\geq$ 10
Tier 2	$8 \leq$ Risk < 10
Tier 3	$6 \leq$ Risk < 8
Tier 4	$4 \leq$ Risk < 6
Tier 5	Risk < 4

Tier 1 and Tier 2 pipelines were used to develop a condition-based capital improvement plan (CIP) for the next 10 years. Only pipes with PACP data were included within the CIP. As the City finishes CCTV of their entire system over the next two years, additional Tier 1 and Tier 2 pipes will be identified and the prioritization may require adjustment.

For mains without PACP scores, a risk score was computed by multiplying the estimated LOF based on remaining useful life by the COF. The pipelines were then sorted based on the risk score to develop a prioritized list of which mains should be CCTV inspected first. The prioritized list of mains has been included in Appendix G This list is an interim document to assist the City in inspecting their highest risk mains and will become obsolete once the City has inspection data on all of their mains.



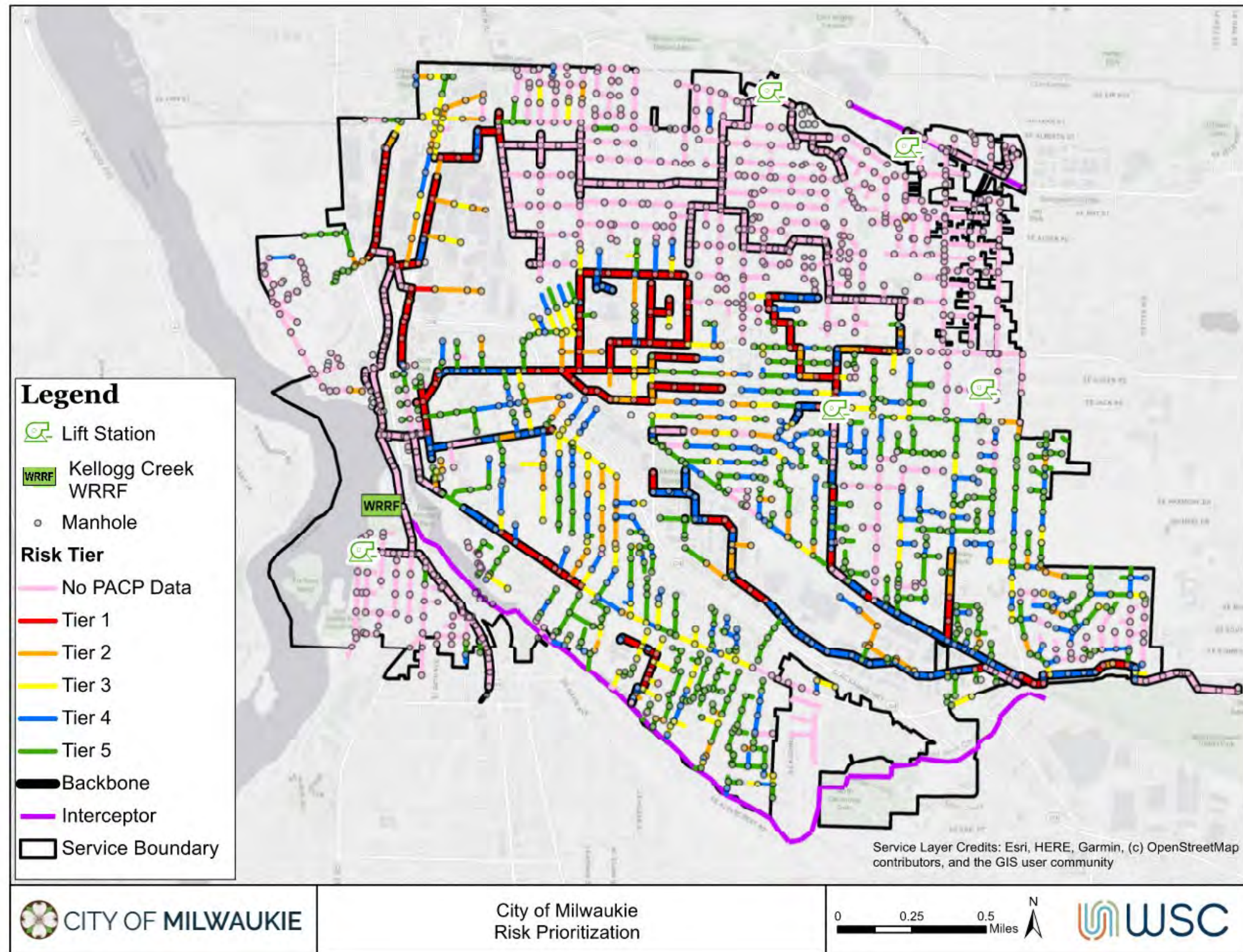


Figure 8-2: Risk Prioritization for Sewer Pipes



## 8.5 Pump Stations

In addition to the sewer collection and conveyance mains, pump stations and force mains will also require rehabilitation and replacement. City operations has indicated that there are not currently any known condition deficiencies at the pump stations that require immediate attention, but given the age of the stations and equipment, some of the critical components will likely reach the end of their useful life within the 20-year planning period of this WWSMP. The typical useful life of pump station equipment can range from as little as 10 years for communications and instrumentation equipment, to 20-25 years for mechanical pumping and electrical equipment, to as long as 50-75 years for below-ground and above-ground structures and piping. Based on original record drawings and pump data sheets provided by the City, the year of original construction and year of last refurbishment are provided in Table 8-12. Based on the available information, all of the stations with the exception of the 55<sup>th</sup> Ave PS (S6) may have pumping and electrical equipment that has reached or is near to the end of its useful life.

**Table 8-12. Pump Station Construction and Refurbishment History**

Lift Station	Year of Construction	Last Refurbishment	Critical Components at End of Useful Life (year) <sup>1</sup>
Island Pump Station (S1)	1973	1993 – Motors Replaced	Pumps and Electrical (present) Structures and Piping (2023)
Harrison Pump Station (S2)	1974	1990 – Pumps Replaced	Pumps and Electrical (present) Structures and Piping (2024)
Home and Monroe Pump Station (S3)	1975	1995 – Motors Replaced 2002 – Pumps Replaced	Pumps and Electrical (2027) Structures and Piping (2025)
Brookside Pump Station (S5)	1999	N/A	Pumps and Electrical (2024) Structures and Piping (2049)
55 <sup>th</sup> Avenue Pump Station (S6)	2011	N/A	Pumps and Electrical (2036) Structures and Piping (2061)

<sup>1</sup> Calculation based on 25-year life for pumps/electrical and 50-year life for piping/structures

## 8.6 Renewal Strategy

The following sections provide recommendations for a comprehensive renewal strategy that includes staffing City maintenance crews to complete spot repairs on pipes that do not require specialized equipment, addressing the highest-risk condition-based deficiencies annually through pipe repair and replacement CIP projects, optimizing the schedule for sewer main inspections, and assessing and refurbishing pump stations.

### 8.6.1 Identification of Repairs to be Completed by City Crews

The City can complete point repairs to rehabilitate sewer pipe where the required excavation depth is 10 feet or less, but deeper excavations exceed the limitations of current City construction equipment. Similarly, the City does not self-perform repairs in high-traffic volume roads where significant traffic control is required due to limitations in current staffing levels and a lack of the necessary equipment. As indicated in Table 8-1, approximately 12,879 linear feet, or 46 individual segments, of PACP scored pipes were identified as Grade 5 with only a single defect. City staff reviewed the CCTV videos for the 46 pipe segments to determine if repairs by a City crew were feasible. Although it appears that the City could complete repairs on nearly one-quarter of these pipes, over half of the pipes were either wrongly coded and no repair was necessary, or the defect was due to a lateral connection and requires repair by the homeowner. Whenever a defect in the privately owned service lateral is found, the case is referred to the City Compliance Officer who issues a citation requiring the owner to correct the defect, typically within 30 days. The findings from the City CCTV review are provided in Table 8-13.

**Table 8-13. City Analysis of CCTV for Point Repair Pipes**

Review Finding	Number of Pipes	Percent of Pipes Reviewed (%)
City Crew Repair is Feasible	13	28
Outside Contractor Required for Repair	6	13
<b>Subtotal – City Required to Repair</b>	<b>19</b>	<b>41</b>
PACP Coding Incorrect – No Repair Needed	10	22
Homeowner Responsible for Repair	17	37
<b>Subtotal – No Repairs by City at This Time</b>	<b>27</b>	<b>59</b>
<b>Total</b>	<b>46</b>	<b>100</b>

A review of the CCTV inspection videos revealed that 59 percent of the Grade 5 defects did not warrant a City-funded pipe repair project due to either incorrect coding or because the defect was actually located within the privately owned service lateral. Only 41 percent of the pipes would require a City-funded repair project, and more than half of those pipes were feasible for repair by a City maintenance crew.

The results of the sample of Grade 5 single-defect pipes described in Table 8-13 above is representative of only 55 percent of the total pipes in the collection system that had PACP scores as of the writing of this WWSMP. Assuming that the findings are indicative of the remaining system for which no PACP data is available, City crews would be required to potentially complete approximately 26 point repairs; the 13 known locations plus an additional 13 that would be discovered as the full collection system CCTV inspections are completed.

Although the City has the capability to perform repairs on single-defect pipe, these activities must be balanced and prioritized along with existing and ongoing responsibilities. Grade 5 defects should be corrected within 5 years of detection at the least, and more rapidly, if possible, to avoid an unplanned pipeline failure. If each repair were to require approximately one week of staff time to plan, execute, and restore any surfaces to original condition, then the equivalent labor requirement would be roughly one half of a year every five years for a work crew of 3 to 4 members, or approximately 5 weeks per year. An evaluation of the anticipated labor demand against other City objectives is recommended to determine if the demand for point repairs could be met through existing staff, if the addition of staff is warranted, or if point repairs will need to be performed by an outside contractor. For now, these spot-repair projects are not recommended for inclusion in the CIP, but if internal resources are insufficient to complete the anticipated volume of repairs, these projects could be prioritized and addressed within the annual CIP budget defined in the following section.

The City should also consider investing in equipment and training for their staff to perform trenchless point repairs or spot repairs. This would allow the City to reduce their reliance on outside contractors while reducing repair costs and providing more schedule flexibility for addressing single Grade 5 defects.

### 8.6.2 Recommended Condition-Based Projects

Similar to the estimates of system-wide repairs that could be completed by City maintenance crews described in the previous section, an estimate of the system-wide CIP rehabilitation needs can be extrapolated from the existing PACP data. Assuming that the available PACP data for 55 percent of the collection system is reflective of the remaining portion of the City system for which this data is currently unavailable, an estimate of the total linear footage of deficiencies can be made and translated into a recommended annual budget for CIP projects. A summary of the projection is provided in Table 8-14.

**Table 8-14. Estimated City-wide Repair Rates**

Category of Pipeline Footage	Backbone (feet)	Non-Backbone (feet)	Total (feet)
Pipe Identified for Repair From Existing Data	6,711	41,640	48,351
Pipe Identified for Repair After CCTV Review <sup>1</sup>	2,752	17,072	19,824
Probable System-wide Pipe Repair <sup>2</sup>	5,003	31,041	36,043
<sup>1</sup> Quantities of known Grade 5 and 4 pipe were reduced by 59 percent in accordance with the proportion of incorrectly coded PACP defects and defects associated with homeowner service laterals found during City review of CCTV inspections. <sup>2</sup> Probable systemwide quantities calculated by applying the ratio of the pipe repair lengths after CCTV review to the total footage of inspected pipe to the total linear footage of collection system piping. PACP inspection data is available for approximately 55 percent of the system.			

The estimate of probable system-wide repair of both backbone and non-backbone pipes can be used to recommend an annual budget for rehabilitation and repair of the collection system. Guidance documents from the United States Environmental Protection Agency indicates that Grade 5 and Grade 4 defects can generally be assumed to have a high probability of resulting in structural failure within 10 years. (21) The quantity of repairs completed in a given year could vary to accommodate budget limitations, but a CIP project (C-1) to complete the rehabilitation and repair of the projected linear footage over the next 10 years is recommended. Approximately 500 LF of backbone pipe and 3,100 LF of non-backbone pipe would need to be repaired annually, on average, to achieve the estimated total repair quantity.

Based on the limited review of PACP-scored pipes conducted as part of this master plan, review of individual CCTV will be required to confirm PACP scoring and to provide more specific repair recommendations for each pipeline. Implementation of the prioritization system described in Section 8.4 would allow the identification of the highest priority repairs to address the highest risk deficiencies. The highest risk repairs could then be bundled together into annual or biannual rehabilitation projects for inclusion in the City CIP budget.

When developing projects, pipelines are recommended to be grouped by location and repair type to generate projects that will yield high contractor interest and competitive pricing. High seismic risk backbone pipes are recommended to be replaced with HDPE or restrained ductile iron pipe to better resist the impacts of ground deformation from an earthquake as described in Chapter 9. These pipelines should be grouped together as they will require a contractor specializing in open trench construction. Pipelines in lower seismic risk areas could be rehabilitated using trenchless technology, such as cured in place pipe (CIPP) or spiral wound PVC pipe liner and should be grouped together as they will require a contractor specializing in trenchless pipe lining. In some areas, it may be advantageous to rehabilitate lower-risk pipe that is adjacent to high-risk pipes to take advantage of economies of scale and to minimize impacts to neighborhoods over multiple years.

### 8.6.3 Optimizing CCTV Inspections

Currently the City inspects all sewers every four years but adjusting the frequency of inspection to match the differing levels of risk could reduce the risk of an unplanned failure. If all Grade 5 and Grade 4 defects are repaired over the next 10 years, there is the risk that some defects may fail before a repair can be implemented. Pipelines with a higher risk score may justify inspection on a more frequent basis to monitor the pipe condition so that prioritization can be adjusted if the severity of the structural deficiencies increases. A proposed adjustment to CCTV inspection frequency is provided in Table 8-15.

**Table 8-15. Proposed CCTV Inspection Frequency**

Pipeline Risk Category	Range of Risk Scores	Proposed Inspection Frequency
High Risk	20-36	Every 2 yrs
Medium Risk	10-20	Every 4 yrs
Low Risk	0-10	Every 6 yrs

In comparison with the current rate of CCTV inspection, the proposed modifications in frequency would result in a lower amount of pipeline footage requiring inspection every year based on the current risk scores. As CIP repair projects are implemented and pipe risk scores are reduced, the amount of pipe footage requiring inspection may decrease every year. It may be possible to repurpose CCTV crews to assist in City point repairs of single-defect pipe as described in Section 8.6.2. Alternatively, if a full-time CCTV crew is preferred, the range of risk scores defining each category could be adjusted to balance the corresponding inspection frequencies to match the current annual rates while achieving the desired risk reduction associated with more frequent monitoring of high-risk pipes.

#### 8.6.4 Sewer Pump Station Assessment

All of the sewer pump stations, with the exception of the S6 55<sup>th</sup> Avenue Pump Station (PS) appear to be nearing the end of expected useful life for the pumps and electrical systems. A detailed condition assessment of each of the stations is recommended to determine the potential repairs that may be required, and to develop a schedule for anticipated refurbishments.

Each pump station assessment should include both a visual assessment of condition, but also should investigate the performance, efficiency, and risk of failure for each station. Even if repairs are not immediately necessary, these aging stations should undergo a full condition assessment every two to three years so that trends in condition of key components can be monitored and repairs can be scheduled appropriately. Condition based repairs at any station should also consider structural seismic improvements. Seismic improvements are discussed in Chapter 9.

Based on the known installation dates of each pump station and the expected useful life of its components, repairs have been estimated for each pump station and organized by the major systems within the station. These repairs should be refined to align with the condition assessment results once completed. Anticipated repairs at each of the City's pump stations and are described in Table 8-16.

**Table 8-16: Pump Station Condition Repair Needs**

Pump Station	I&C <sup>1</sup>	Electrical	Mechanical Pumping	Seismic	Full Rebuild
Island Pump Station (S1)					X
Harrison Pump Station (S2)	X	X	X		
Home and Monroe Pump Station (S3)	X	X	X	X	
Brookside Pump Station (S5)	X	X	X	X	
55 <sup>th</sup> Ave Pump Station (S6)	X	X	X		

<sup>1</sup>I&C = Instrumentation and Communication



The repair needs indicated for each of the major systems are anticipated within the 20-year planning horizon of this WWSMP. To determine the timing and extent of repairs for each system, a condition assessment will be necessary for each station. Instrumentation and communication and electrical repairs will likely consist of upgrading any equipment that has become obsolete and for which replacement parts are no longer available, or where reliability, efficiency, or accuracy has degraded below acceptable levels. Mechanical pumping equipment will consist of replacing pumps and motors to address changes in pump station capacity needs, or where reliability and efficiency have degraded below acceptable levels. Seismic retrofits are described in more detail in Chapter 9.

### 8.6.5 Projects from the 2010 WWSMP

In discussions with the City, several projects identified in the 2010 WWSMP have not yet been completed and will need to be carried over into this WWSMP update. These projects include the following:

- Johnson Creek Siphon Replacement. Although the replacement of the siphon was recommended, the project was given low-priority and was not scheduled within the 5-year planning period from 2012 to 2016. Based on discussions with City staff, a CCTV inspection of the siphon piping has not been conducted due to the operational difficulties associated with bypassing and draining the pipeline. Prior to recommending a full replacement, WSC recommends a siphon inspection project to assess the condition of the pipeline and to define the specific repairs necessary.
- Waverly Heights Sewer System Reconfiguration. Construction of new sewer lines, along with repairs to existing lines, was recommended to address condition and ownership issues within the Waverly Heights neighborhood. The City has included an updated description of this project within the current 2021-2026 CIP Budget, and plans to commence design efforts in fiscal year 2023 (FY23) followed by construction in FY24 and FY25.

## 8.7 Project Recommendations

Based on the analysis in the previous sections, WSC developed a list of condition-based projects to address the deficiencies within the City's collection system over the 20-year planning period. Each project is identified in Table 8-17. Costs for each project are provided in Chapter 10.

**Table 8-17. Summary of Condition-Based Project Recommendations**

Project Number	Capital Projects to Address Condition Deficiencies
C-1	Annual collection system pipeline rehabilitation and replacement projects.
C-2	Detailed condition assessment of all existing pump stations.
C-3	Island Pump Station (S1) rehabilitation and replacement
C-4	Harrison Pump Station (S2) rehabilitation and replacement
C-5	Home and Monroe Pump Station (S3) rehabilitation and replacement
C-6	Brookside Pump Station (S5) rehabilitation and replacement
C-7	55 <sup>th</sup> Avenue Pump Station (S6) rehabilitation and replacement
C-8	Johnson Creek Siphon Inspection
C-9	Waverly Heights Sewer System Reconfiguration

## CHAPTER 9

# System Resilience

This section provides an analysis of the potential impacts to the City's wastewater collection system from an earthquake and climate change and provides recommendations for improving the resilience of the system.

## 9.1 Seismic Resilience

In March of 2019, the City prepared an addendum to the Clackamas County Multi-Jurisdictional Natural Hazard Mitigation Plan (County NHMP). As part of the risk assessment process, a Cascadia Subduction Zone (CSZ) magnitude 9.0 (M9.0) earthquake and a smaller magnitude crustal earthquake were identified as the two top-ranked hazards. A resulting action item from the County NHMP was to conduct seismic evaluations on critical and essential facilities and infrastructure and to implement appropriate structural and non-structural mitigation strategies.

WSC partnered with SEFT and McMillan Jacobs Associates (MJA) to conduct a seismic evaluation of the City's collection system. For consistency with the County NHMP and the Oregon Resilience Plan, a CSZ M9.0 seismic event was selected as the basis for analysis. The seismic analysis consisted of establishing level of service goals following the earthquake, identifying the collection system backbone serving critical facilities, identifying geohazard areas within the City's collection system, determining critical facility risk and identifying a seismic mitigation plan to address these risks and upgrade the collection system to facilitate meeting level of service goals.

---

### IN THIS SECTION

Seismic Resilience

Climate Resilience

---

### 9.1.1 Level of Service Goals

Seismic resilience planning involves establishing level of service (LOS) goals that define the desired level of system performance following an earthquake, in this case a M9.0 CSZ earthquake. SEFT analyzed the LOS goals from leading resilience planning documents, including the San Francisco Planning + Urban Research Association Resilient City documents, the Oregon Resilience Plan, the National Institute of Standards and Technology Community Resilience Planning Guide, and the San Francisco Public Utilities Commission seismic design requirements. The best practices from these documents were adapted to fit the City's wastewater collection system and presented to the City at a LOS workshop where they were further refined to meet the City's needs. The resulting LOS goals for the City's collection system are presented in Table 9-1. Additional information on the LOS planning process is included in SEFT's technical memorandum included as Appendix H.

### 9.1.2 Critical Infrastructure

To meet the LOS goals identified in Table 9-1, WSC partnered with the City to identify the sanitary sewer backbone of the collection system that will be critical for restoring service following a major earthquake. The backbone consists of large trunk mains, the siphons, lift stations and pipes serving facilities that connect to critical facilities, such as hospitals, the City's well sites, and schools, and is shown in Figure 9-1.

Identification of the backbone system provides the framework for conducting a seismic risk analysis of the collection system against the defined LOS described in the previous section. By limiting damage to the backbone, sewer service will be able to be more quickly restored to critical facilities and the majority of residents following a major earthquake. In addition to the collection system piping, the backbone system also includes the following pumping stations and their respective force mains:

- Island Pump Station (S1)
- Home and Monroe Pump Station (S3)
- Brookside Pump Station (S5).

Additional facilities are critical to the conveyance and treatment of wastewater for the City but are not included within the City's backbone system because they are not owned or maintained by the City. The Kellogg Creek WRRF and the Kellogg Interceptor provide conveyance and treatment of wastewater and are shown in Figure 9-1 to aid in the understanding of the collection system, but these assets are not considered to be part of the City backbone sewer infrastructure. Additional information on the backbone can be found in SEFT's technical memorandum included as Appendix H.

**Table 9-1: Wastewater Level of Service Goals (22)**

Wastewater Systems	Target Timeframe for Recovery								
	Phase 1: Short-Term			Phase 2: Intermediate			Phase 3-Long Term		
	Days			Weeks			Months		
	0-1	1-3	3-7	1-2	2-4	4-12	3-6	6-9	9-12
<b>Major Trunk Lines and Associated Lift Stations</b>									
Backbone conveyance facilities (major trunk line, lift station, etc.)			Backbone Capable of Routing 30% AWWF <sup>1</sup> to Treatment Plants			Backbone Capable of Routing 60% AWWF to Treatment Plants		Backbone Capable of Routing 90% AWWF to Treatment Plants	
<b>Control Systems</b>									
SCADA and other control systems								90% Operational	
<b>Collection Lines and Associated Lift Stations</b>									
<b>Critical Facilities</b>									
Hospitals, EOC, Police Stations, Fire Stations		90% of Generated Flow Routed to Treatment Plants							
<b>Emergency Housing</b>									
Emergency Shelters			90% of Generated Flow Routed to Treatment Plants						
<b>Housing/Neighborhoods</b>									
Threats to public health and safety controlled by containing and routing raw sewage away from public			30% of Generated Flow Routed to Treatment Plants	60% of Generated Flow Routed to Treatment Plants		90% of Generated Flow Routed to Treatment Plants			
<b>Community Recovery Infrastructure</b>									
All other clusters							30% of Customer Connections Restored	60% of Customer Connections Restored	90% of Customer Connections Restored

1. AWWF = Average Wet Weather Flow

Desired time to restore components to 30% operational  
 Desired time to restore components to 60% operational  
 Desired time to restore components to 90% operational

R
Y
G



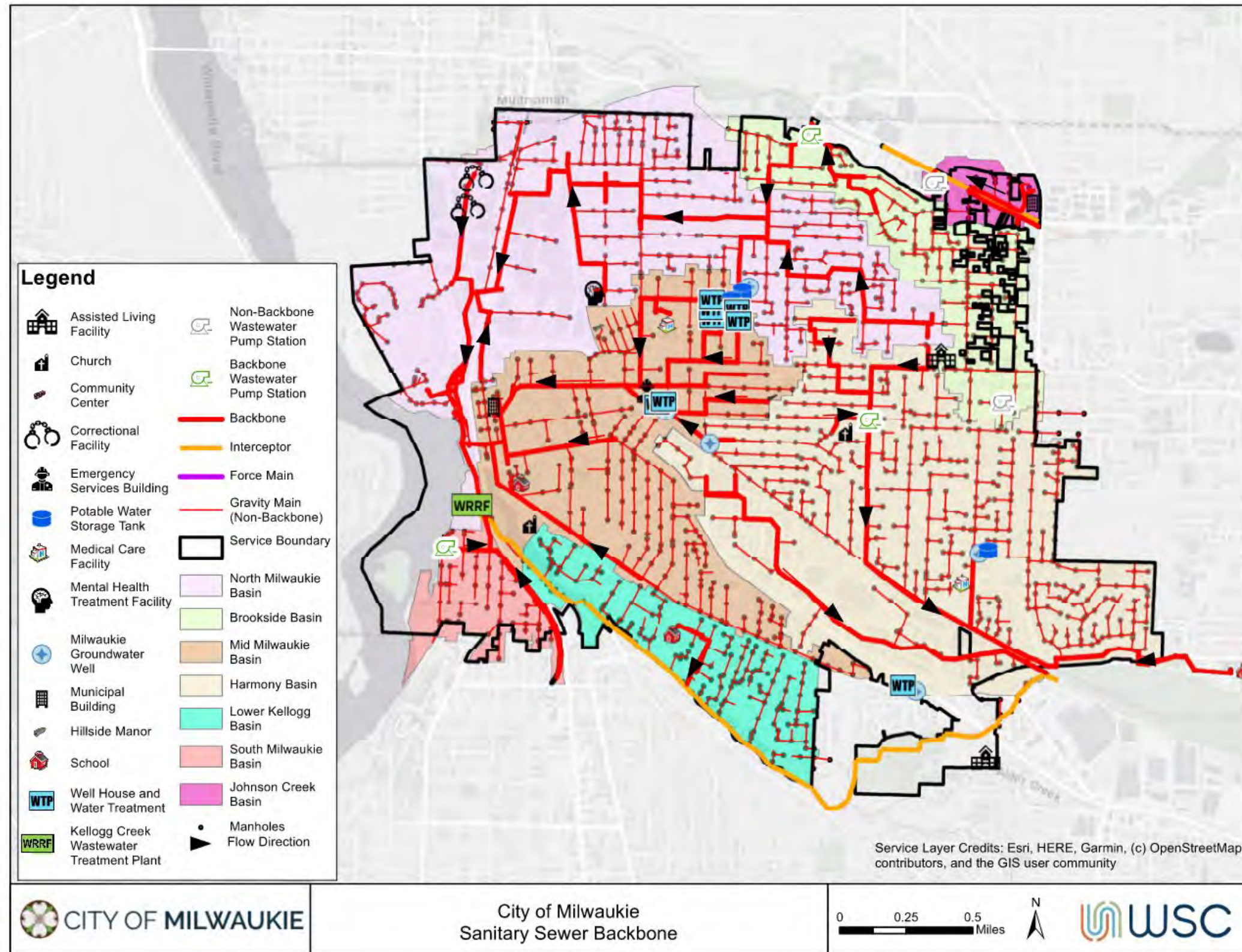


Figure 9-1: Sanitary Sewer Backbone Infrastructure

### 9.1.3 Seismic Geohazards

MJA performed a geohazard analysis by reviewing the DOGAMI seismic hazard maps for a M9.0 CSZ event in the City's service area. The maps were verified and refined by incorporating geotechnical boring information from past City projects as well as using available well information from the Oregon Department of Water Resources. MJA also performed site reconnaissance of critical facilities to identify site conditions, exposed soil conditions, site topography, proximity to bodies of water, and constructed features. The facilities visited included:

- Kellogg Creek WRRF
- Island Pump Station (S1)
- Harrison Pump Station (S2)
- Home & Monroe Pump Station (S3)
- Brookside Pump Station (S5)
- 55<sup>th</sup> Ave Pump Station (S6).

Using the information collected from geotechnical data and site visits, MJA evaluated the City's service area for ground shaking, liquefaction settlement, lateral spreading, and seismic-induced landslides. The following subsections describe the probable magnitude of seismic geohazards, and sections 9.1.4 and 9.1.5 provide analysis of potential seismic risks to sewer pipelines and pumping stations, respectively.

#### 9.1.3.1 Ground Shaking

Ground shaking was evaluated for the City's service area by examining the peak ground velocity (PGV) for a M9.0 CSZ earthquake. The PGV is dependent on the earthquake's magnitude, its distance to fault rupture, and the subsurface material at the site. PGV values were estimated to be between 10 and 12 inches per second for the majority of the City's service area, but higher values between 12 and 15 inches per second are anticipated along the shores of Kellogg Creek and the Willamette River where critical backbone conveyance infrastructure is located. Slightly lower PGV values were found in the low-lying areas of the City while slightly higher PGV values were found in higher elevation areas, such as Waverly Heights and the eastern service area. A map showing the PGV for the City's service area is shown in Figure 9-2.

### 9.1.3.2 Liquefaction

Liquefaction settlement occurs in saturated, granular soils when rapid shearing, such as from an earthquake, causes drastic loss in shear strength and causes the soil to transform from a granular solid mass into a viscous, heavy fluid mass. This can result in the loss of soil materials through sand boils; flotation of buried pipelines, wet wells or other structures; and post liquefaction settlement. The resulting peak ground deformation (PGD) is estimated in terms of the maximum amount of ground movement that may occur within an area. A map showing the liquefaction settlement PGD for the City's service area is included in Figure 9-3. The low-lying areas near the Willamette River, Kellogg Creek and Johnson Creek are most susceptible to liquefaction settlement, with some areas expected to experience more than 6 inches of settlement. Approximately two-thirds of the City's service area is expected to experience no PGD due to liquefaction.

### 9.1.3.3 Lateral Spreading

Lateral spreading is a form of liquefaction that results in progressive ground deformation of the surrounding soil as the lateral movement of liquefied soil breaks the non-liquefied soil crust into blocks. Seismic ground accelerations incrementally push these blocks downslope or toward a free face as the ground acceleration overcomes the strength of the liquefied soil column. A map identifying the liquefaction lateral spreading within the City's service area is shown in Figure 9-4. The primary areas of concern for lateral spreading are located along the slopes near Johnson Creek, Kellogg Creek, and the Willamette River.

### 9.1.3.4 Seismic Landslides

Seismic landslides occur when the inertial force from the earthquake adds load to a slope resulting in the slope failing. These landslides can cause extremely large ground movements that can cause significant damage to both buried and above-ground facilities. A map identifying seismic landslide potential as well as historical landslides is shown in Figure 9-5. Seismic landslide potential is limited to isolated areas within the City with steeper slopes, primarily at roadway embankments and the south bank of Johnson Creek.



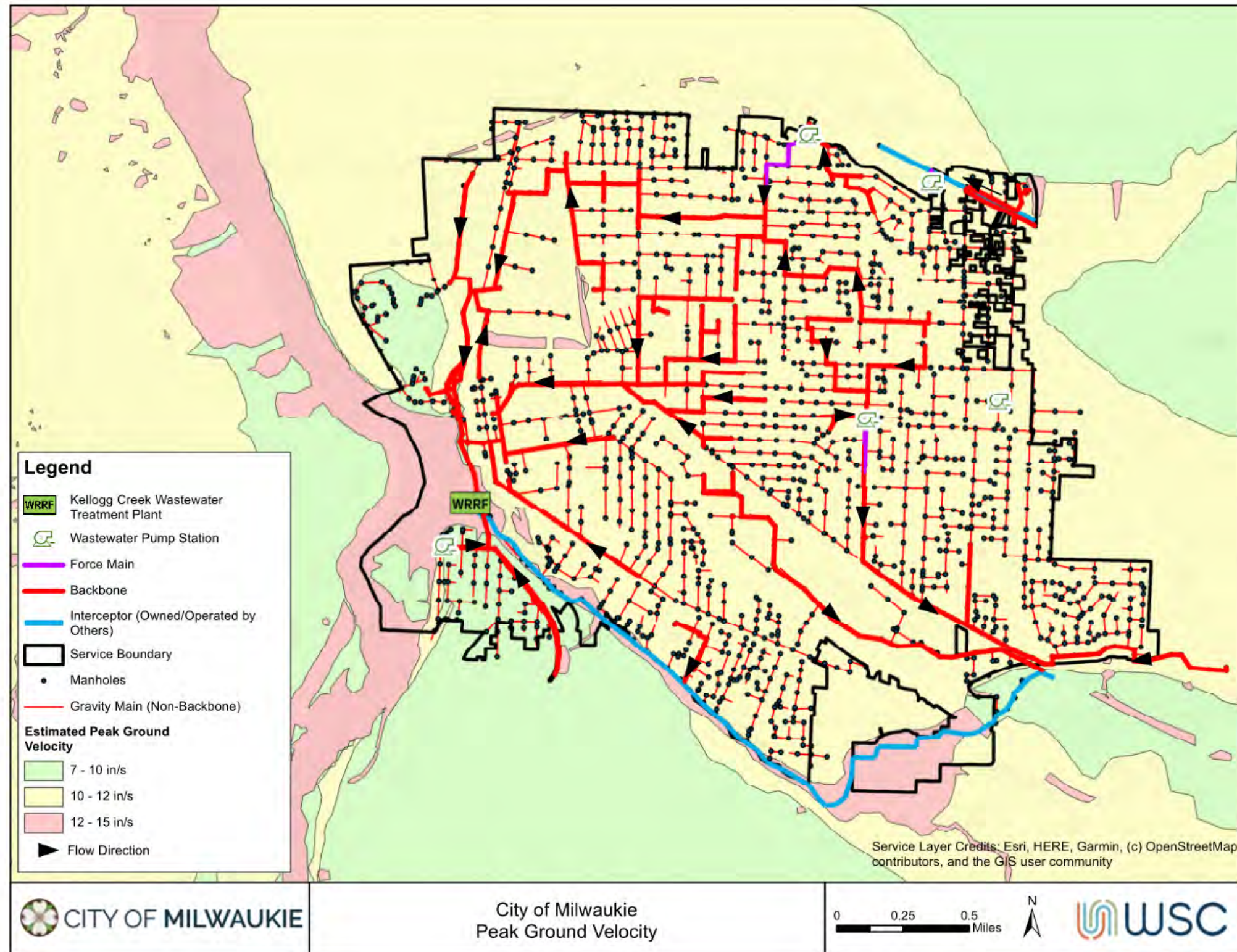


Figure 9-2: Peak Ground Velocity for M9.0 CSZ Earthquake



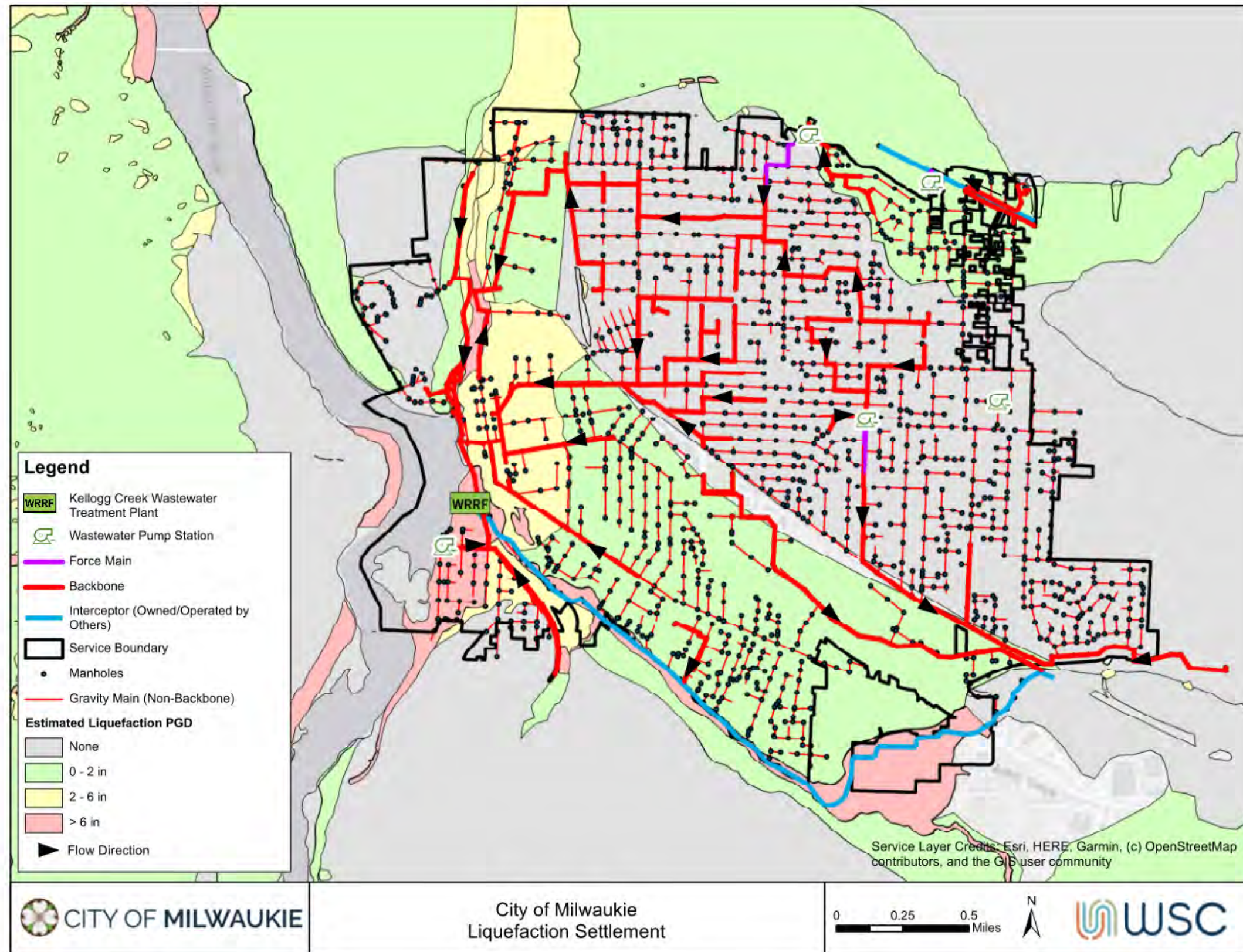


Figure 9-3: Liquefaction Settlement PGD for M9.0 CSZ Earthquake



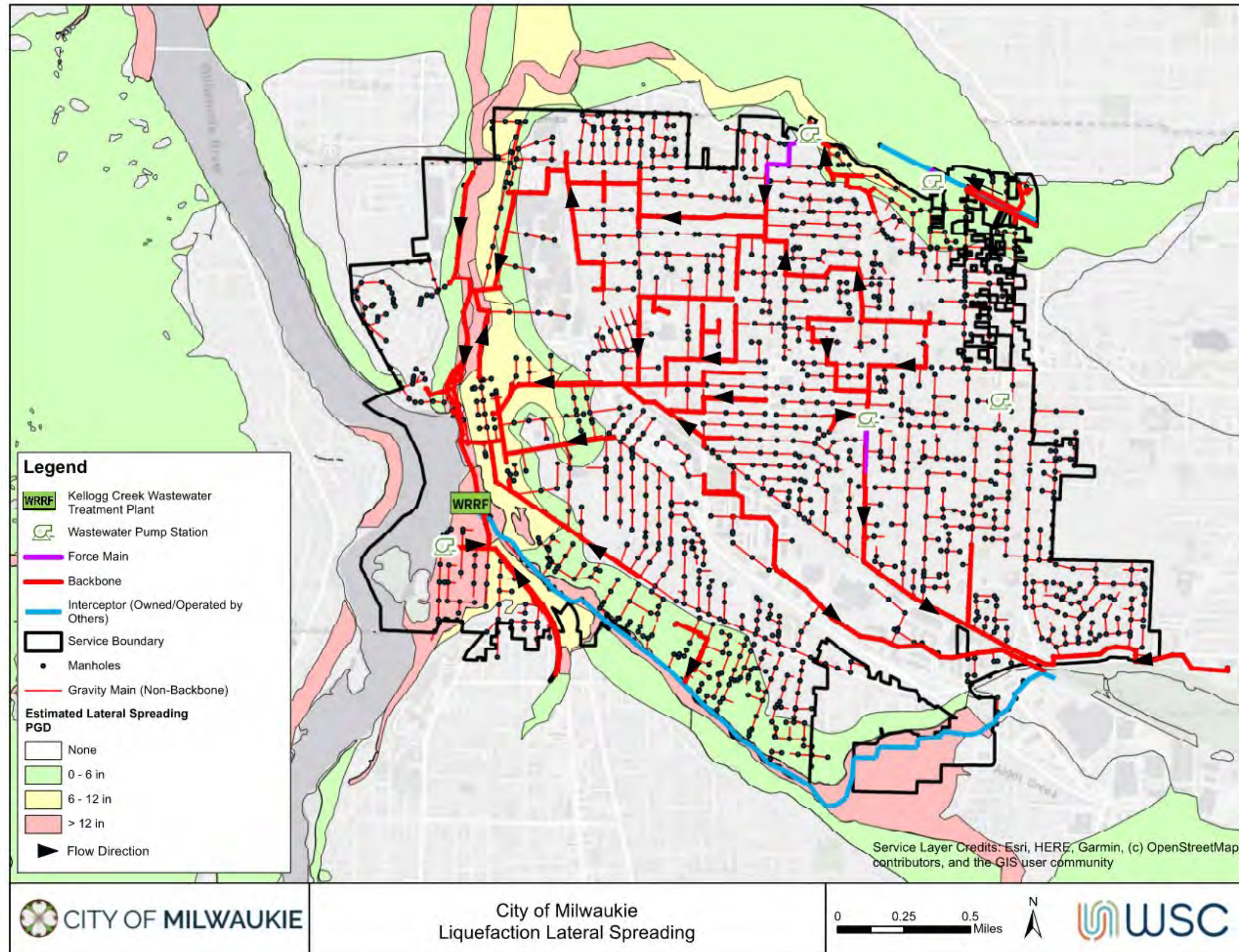


Figure 9-4: Liquefaction Lateral Spreading PGD for M9.0 CSZ Earthquake



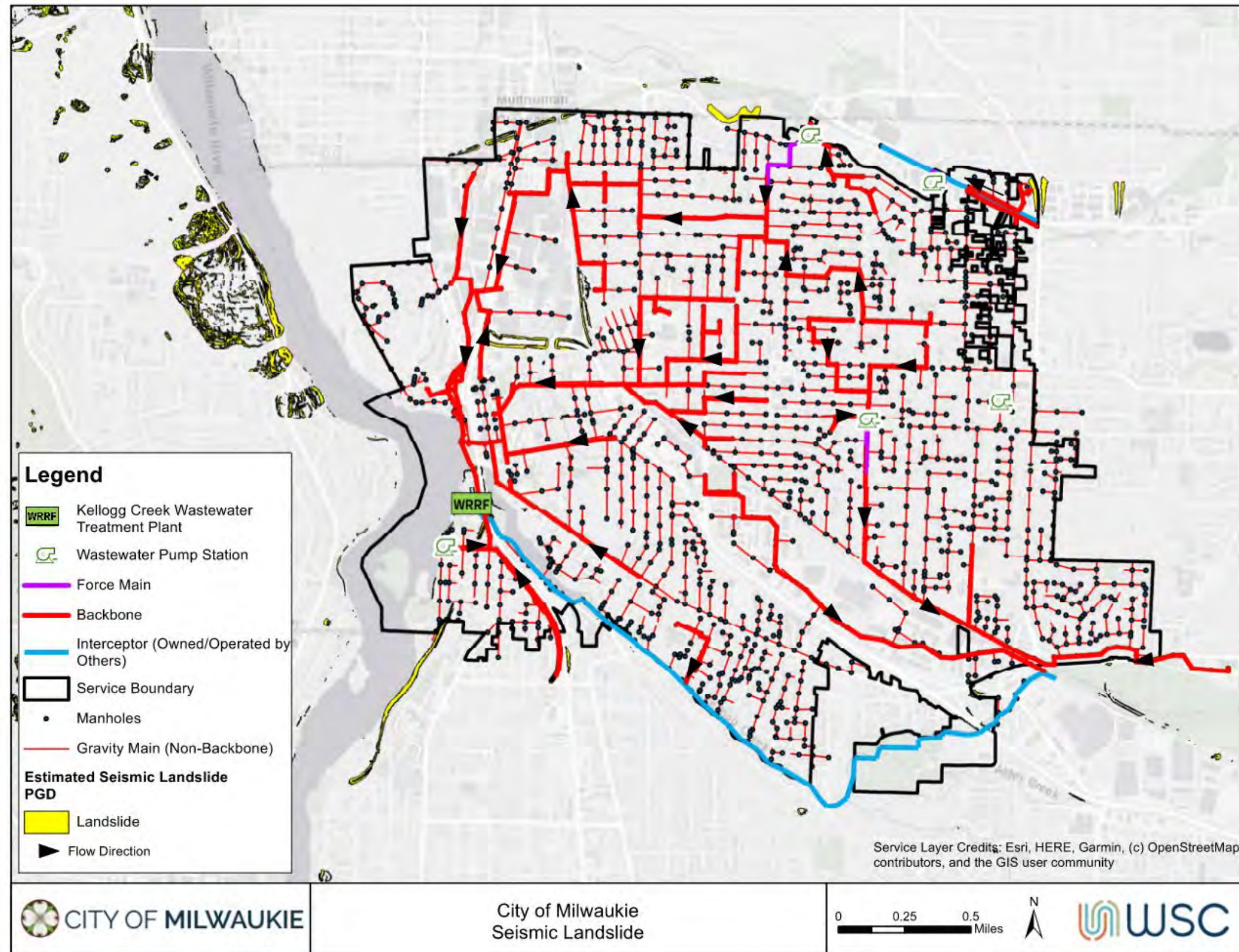


Figure 9-5: Seismic Landslide PGD for M9.0 CSZ Earthquake

### 9.1.3.5 Seismic Hazards for Critical Facilities

Many of the City's sewage pump stations are vulnerable to seismic damage due to their location near water bodies and the resulting soil conditions. Table 9-2 outlines MJA findings for the impact on critical facilities. The Kellogg Creek WRRF is included in this analysis even though it is owned and operated by WES due to its importance as the primary treatment option for the City's collection system.

**Table 9-2: Seismic Hazards for Critical Facilities**

Structure	Primary Geotechnical Seismic Concerns and Issues
Kellogg Creek WRRF	Large magnitude PGD towards the Willamette River as a result of liquefaction induced settlement and lateral spreading.
Island Pump Station (S1)	Large magnitude PGD towards the Willamette River as a result of liquefaction induced settlement and lateral spreading.
Harrison Pump Station (S2)	Strong ground shaking
Home and Monroe Pump Station (S3)	Strong ground shaking
Brookside Pump Station (S5)	Liquefaction of saturated unconsolidated soils and lateral spreading towards Johnson Creek resulting in significant PGD.
55 <sup>th</sup> Avenue Pump Station (S6)	Liquefaction of saturated unconsolidated soils and lateral spreading towards Johnson Creek resulting in significant PGD.

### 9.1.4 Collection Sewer Pipeline Risk Analysis

Unlike water systems, there is limited research on the seismic pipe fragility of sewer infrastructure. For water infrastructure, the current best practice is using the *Seismic Fragility Formulations for Water Systems* published by the American Lifelines Alliance (ALA). This document compiles research from past earthquakes and creates fragility formulas for calculating an expected repair rate of a pipeline based on the seismic parameters (PGV or PGD) and the pipe type. Due to the limited research, the ALA document is often modified for use in collection systems. However, it lacks many of the pipe types used in a collection system, such as vitrified clay pipe, since it is based on potable water pressure pipelines.

A 2015 study analyzed pipe fragility on collection systems from the Canterbury (New Zealand) Earthquake sequence in 2010-2020 and found that the fragility functions for potable water pipelines tend to underestimate the physical damage to gravity sewer pipelines. (23) Gravity pipelines are subject to failure in different ways than potable water pressure pipelines which results in this discrepancy. However, these fragility formulas still provide a useful tool for prioritizing which mains require improvements for withstanding a CSZ seismic event. Since the ALA guidelines are missing pipeline fragility constants for many of the sewer pipeline materials for use in the fragility formulas, WSC estimated fragility constants for these missing materials based on the ductility of the material and joints. The pipeline fragility constants and the equations used in the fragility analysis are presented in Table 9-3. Higher fragility constants represent more brittle pipe materials that are more likely to break under a seismic load.



Table 9-3: Pipeline Fragility Constants

Pipe Material	K <sub>1</sub> Typical Range	K <sub>1</sub> Assumed Value	K <sub>2</sub> Typical Range	K <sub>2</sub> Assumed Value	Supporting assumptions
Cast Iron	0.7-1.4	0.8	0.7-1.0	0.8	Assume rubber gasket joints
Concrete Pipe Unreinforced	0.7-1.0	1.0	0.6-1.0	1.0	Includes unreinforced concrete & concrete segment pipe
Ductile Iron	0.5	0.5	0.5	0.5	Assume rubber gasket joints
HDPE	NA	0.15	NA	0.15	Assume fusion welded joints
PVC	0.5	0.5	0.8	0.8	Assume rubber gasket joints
Reinforced Concrete Pipe	0.7-1.0	0.8	0.6-1.0	0.8	Assume rubber gasket joints
Steel	0.15-1.3	0.7	0.15-0.7	0.7	Assume rubber gasket joints
Vitrified Clay	NA	1.0	NA	1.0	Assume rubber gaskets joints
Unknown	NA	1.0	NA	1.0	Assumed a conservative value
Equation 1: $RR = K_1 * 0.00187 * PGV$				Equation 2: $RR = K_2 * 1.06 * PGD^{0.319}$	
NA = not available RR = rate of repairs per 1,000 feet of pipe K <sub>1</sub> = fragility curve modification factor for ground shaking K <sub>2</sub> = fragility curve modification factor for permanent ground deformation PGV = peak ground velocity in inches per second PGD = peak ground deformation in inches					

Using the seismic hazard mapping and the ALA fragility calculations, estimated repair rates per 1,000 feet of pipe were calculated for the backbone and non-backbone pipelines within the City's collection system. A graphic representation of the repair rates for the backbone system and the collection system as a whole are shown in Figure 9-6 and Figure 9-7, respectively.

The fragility of any pipeline is affected significantly more by PGD from liquefaction, lateral spreading, or landslides than from ground shaking as measured by PGV. Thus, a higher frequency of repair rates can be anticipated within pipelines that are located in areas of higher PGD.

Based on the analysis, the City's backbone system shows vulnerability to breakages during a CSZ seismic event in the areas near the Willamette River on the western side of their collection system. Poor soil conditions in this area are prone to high levels of ground deformation that, when combined with brittle pipe materials, are expected to result in a high level of breaks. The largest diameter City trunk sewers which convey wastewater for approximately two-thirds of the service area are located along the Willamette River's eastern banks where the highest estimated PGD is expected to occur. Due to the vicinity to the Kellogg Creek WRRF, breaks in this area of the system will contain large quantities of untreated sewage. The eastern portion of the collection system is expected to perform much better due to improved soil conditions in those areas.

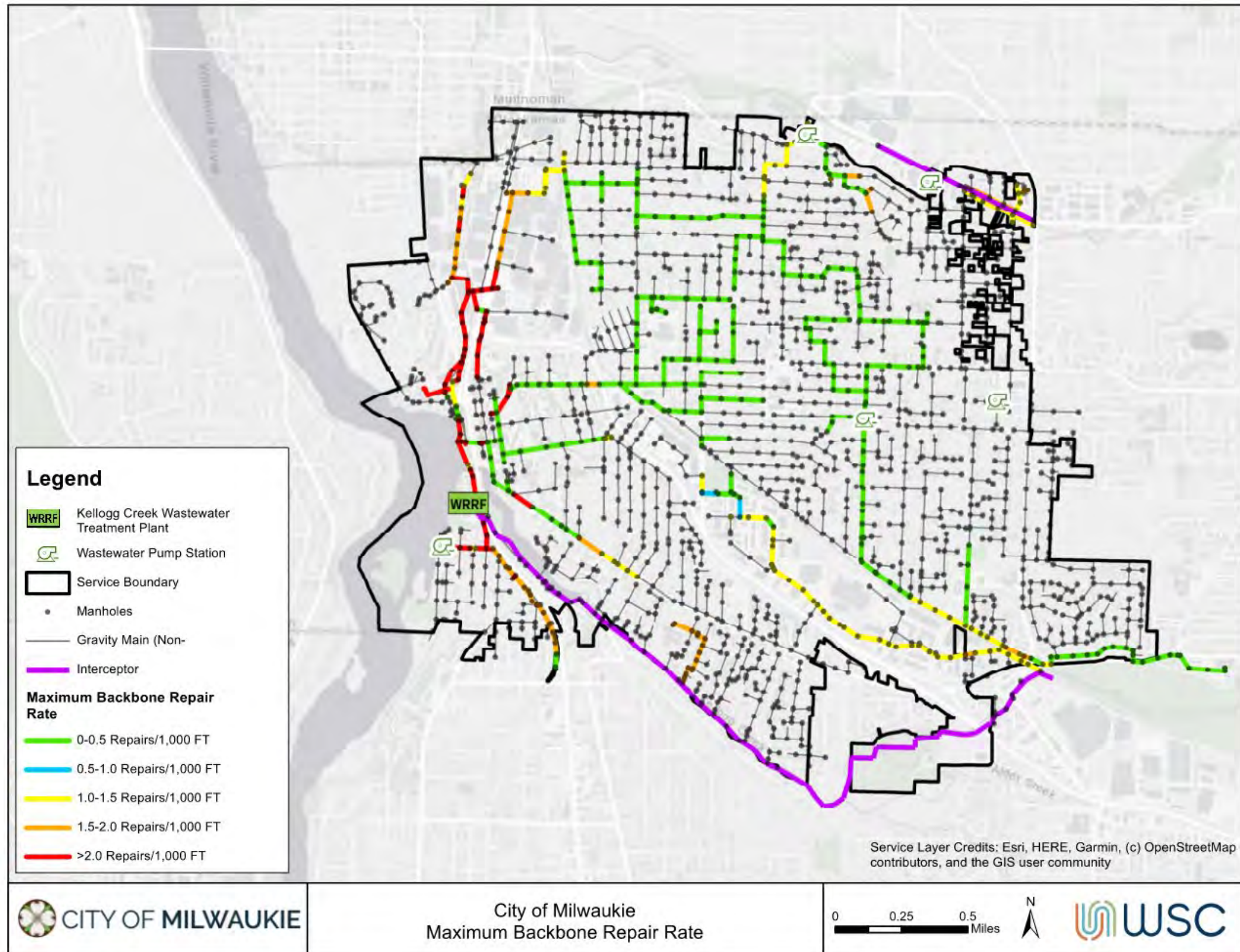


Figure 9-6: Estimated Repair Rates for the Backbone Collection System



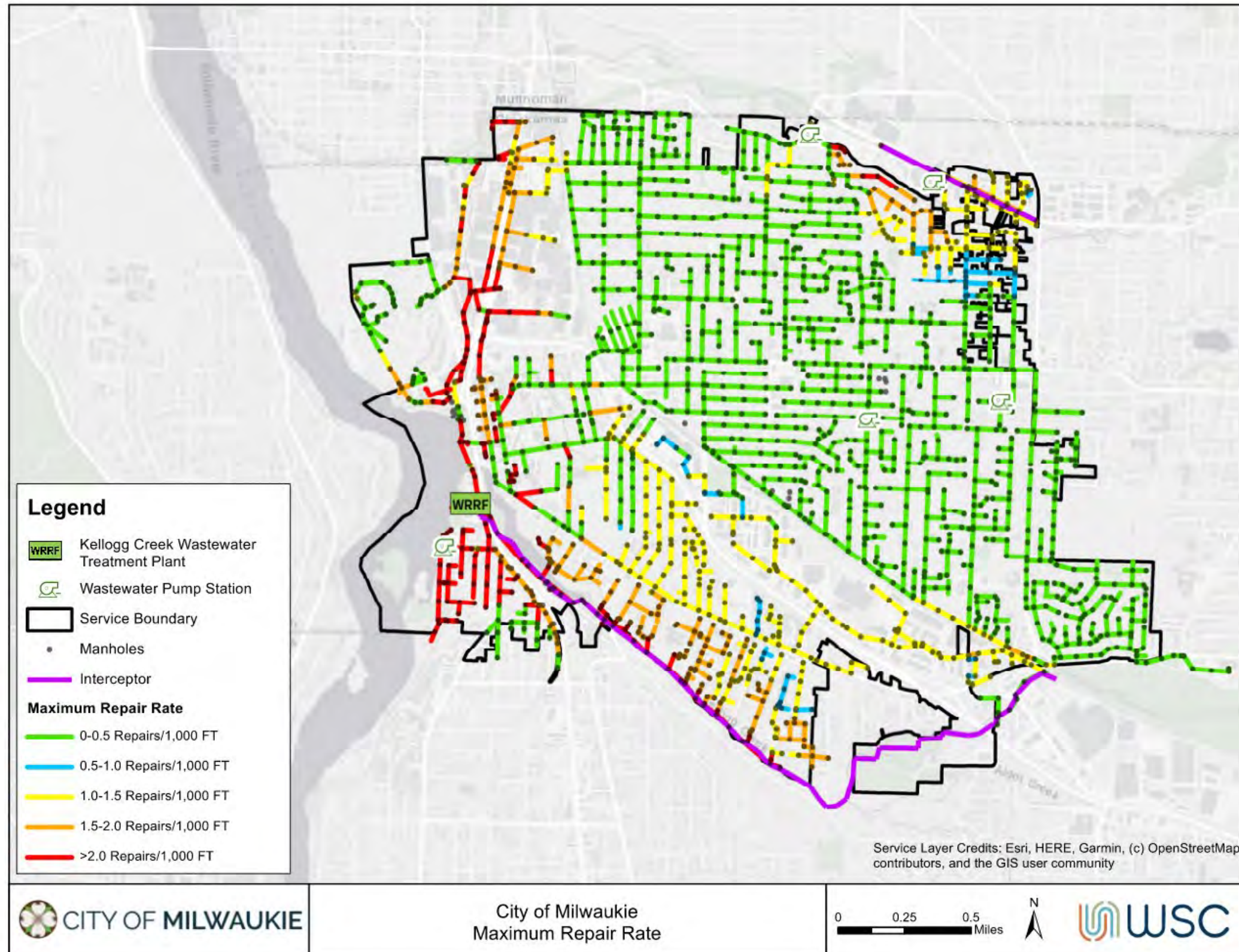


Figure 9-7: Estimated Repair Rates for the City's Collection System

### 9.1.5 Pump Station Risk Analysis

In addition to the sewer pipelines described in the previous section, pump stations also comprise a portion of the critical backbone of the wastewater collection system and include the following:

- Island Pump Station (S1)
- Home and Monroe Pump Station (S3)
- Brookside Pump Station (S5).

These pump stations are included within the critical backbone system because they are required to provide wastewater conveyance to a significant portion of the service area or there are critical facilities that discharge into the upstream gravity sewer.

To understand the potential risk to each station from a CSZ M9.0 event, SEFT conducted assessments of the existing structures and components of the Home and Monroe Pump Station (S3) and the Brookside Pump Station (S5) using the anticipated spectral acceleration and PGD displacements identified during the seismic hazard assessment. Each facility was assessed for a structural performance objective of Immediate Occupancy that would allow continued use of the building and a non-structural performance objective of Operational that would allow the facility to remain functional following a seismic event. The existing Island Pump Station (S1) was not assessed due to the high magnitudes of lateral spreading PGD anticipated at the current location and the original year of construction. In SEFT's experience, it is typically more cost-effective to replace these structures with a modern seismic resilient designed facility, so an assessment of the existing structures would not provide much value to the City. A list of potential seismic deficiencies for each station is provided in Table 9-4. The complete Lift Station Evaluation Technical Memorandum is provided in Appendix I.

**Table 9-4: Preliminary Pump Station Seismic Retrofit Recommendations**

Potential Seismic Deficiencies	Home and Monroe Pump Station (S3)	Brookside Pump Station (S5)
Relative Movement Between Structures Could Damage Pipes	✓	✓
Precast Wet Well Joints Could Separate	✓	✓
Pipes, Pumps and Equipment, and Electrical Cabinets Need Bracing	✓	✓
Pole-Mounted Transformer May Not Withstand Seismic Shaking	✓	
Building Framing and Shear Walls May Not Meet Current Code		✓

### 9.1.6 Seismic Mitigation Plan/Recommendations

The seismic evaluation of the wastewater system has led to the development of several mitigation recommendations that are described in the following subsections.

### 9.1.6.1 Programmatic Replacement of High Priority Pipelines

Although the risk to the City’s wastewater system from a seismic event is identified as a top-ranked priority for mitigation, the costs of retrofitting miles and miles of pipelines to withstand the anticipated ground movements is enormous. The financial burden to improve resilience is recognized in the Oregon Resilience Plan and was addressed by setting a 50-year timeline for hardening the critical infrastructure that will be required to achieve the desired LOS following a seismic event. As described in Chapter 8, sewer pipelines are typically expected to have a 75-year useful life. Based the installation dates and expected useful life, the majority of the collection system pipes will require rehabilitation or replacement within the next 50 years. When pipes reach the end of their useful life, replacement or repairs can be implemented in a manner that provides seismic mitigation.

To prioritize the mitigation of seismic risk within the sewer system, each pipe has been identified as high, medium, or low seismic risk. The level of seismic risk is included in the risk-based prioritization of biennial rehabilitation and replacement projects described in Chapter 8. A description of the criteria for each seismic risk category is provided in Table 9-5 and a map of the system with color coding associated with each category is provided in Figure 9-8.

**Table 9-5: Programmatic Seismic Retrofit Recommendations for Sewer Pipes**

Seismic Risk Category	Risk Category Delineation	Site Specific Geotech Investigation	Preliminary Recommended Improvements
High	Fragility > 1.5 repairs per 1,000 feet and part of Backbone System	Recommended prior to any repairs	Replace w/ Fused HDPE or Restrained DIP
Medium	1.0 repairs per 1,000 feet < Fragility < 1.5 repairs per 1,000 feet and part of Backbone System	Recommended prior to any repairs	Replace w/ Fused HDPE, Restrained DIP, PVC, or line with CIPP
Low	Fragility > 1.0 repairs per 1,000 feet	Recommended prior to full pipe replacement	Replace with PVC or line with CIPP
None	Fragility < 1.0 repairs per 1,000 feet	Not required	Replace with PVC or line with CIPP



For each seismic risk category, a preliminary recommendation is provided for conducting a site-specific geotechnical investigation and for possible seismic improvements. The High seismic risk category generally consists of backbone pipe located in areas with a higher magnitude of anticipated PGD. Without additional site-specific information, pipes at the end of their useful life in the High category should be replaced with materials with high ductility and restrained joints such as fused HDPE or restrained ductile iron pipe (DIP) that can better withstand large deflections and reduce the risk of joint pull-out. In locations where significant displacement is anticipated based on site specific findings, relocation of the sewer alignment to areas with less probability for deformation may be warranted, or the use of specially designed seismic joints may be required with DIP to accommodate greater deflection and joint movement. For pipes in the Medium, Low, or None categories, less ductile materials such as PVC can be considered for replacement, and pipes that can be rehabilitated with CIPP will also gain improvements in seismic performance. CIPP is likely to provide adequate protection against joint pull out for pipes in the Low seismic risk category, but further geotechnical investigation is likely necessary to determine if this rehabilitation method will maintain the desired level of service within the Medium seismic risk category pipes.

The seismic risk category is used along with pipe condition and consequence of failure rankings to prioritize replacements and/or repairs. As described in Chapter 8, the ongoing condition-based repair and replacement program will be budgeted programmatically. WSC recommends that City staff consider prioritizing the highest ranked pipes in terms of risk for repairs during each budgeting cycle. Further discussion of the anticipated annual costs for the program is provided in Chapter 10.



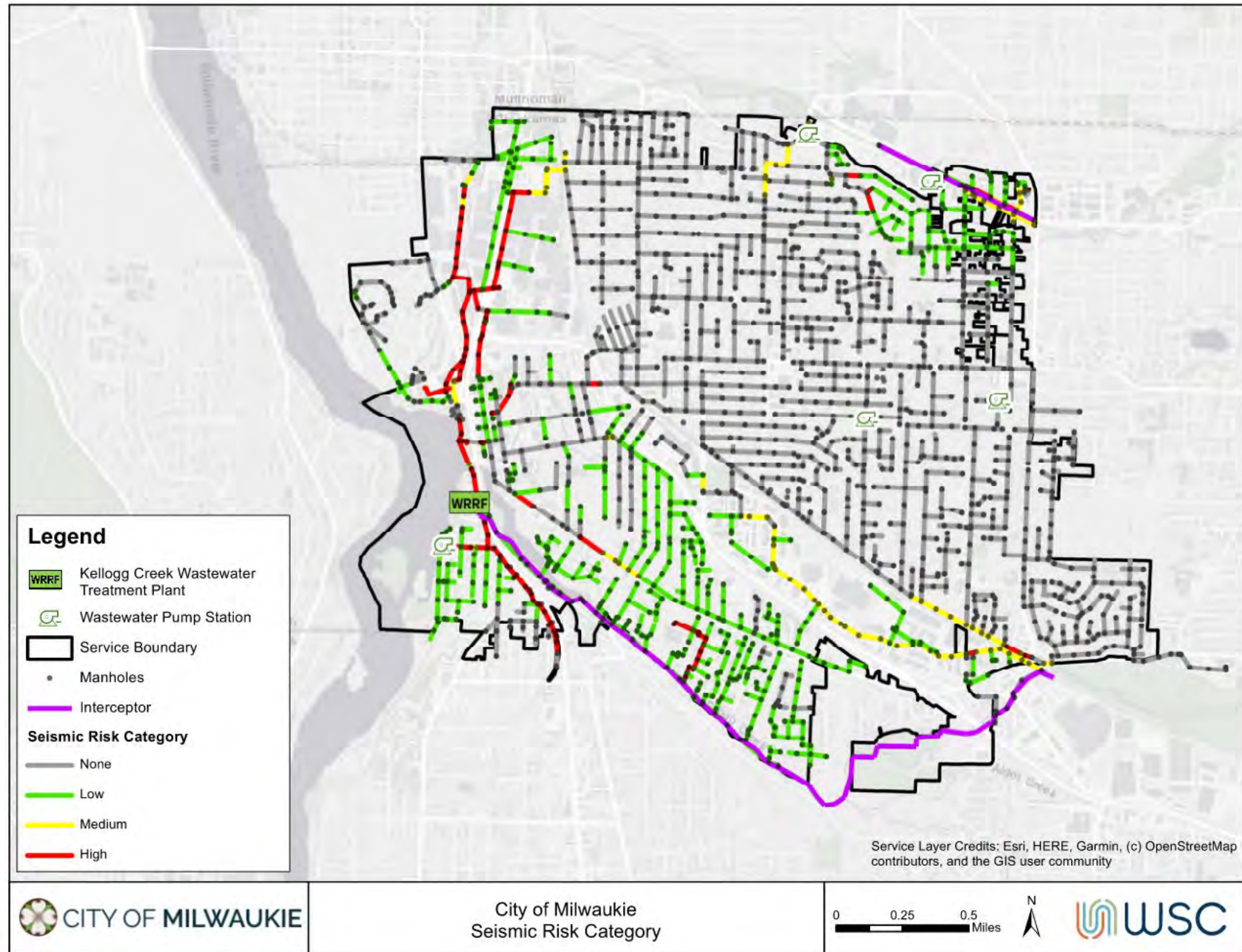


Figure 9-8: Seismic Risk Prioritization

### 9.1.6.2 Updated Design Standards for New Pipe

The City's Public Works Standards currently require new sewer collection pipelines to be PVC as specified in the Oregon Standard Specifications for Construction. The current standards also allow for Class 50 DIP in areas where additional strength is required, and high-density HDPE when authorized by the City Engineer. The current standards do not adequately address when additional strength or flexibility is required to address anticipated ground movement caused by seismic events.

Research and data collection in the aftermath of the Canterbury earthquake sequence from 2010 through 2011 in Christchurch, New Zealand found that both PVC and HDPE pipes experience much fewer breaks during ground shaking. For pipes with low or no seismic risk, the current City standard for PVC pipe does not require update. However, for areas of medium to high seismic risk, PVC may not be an acceptable material because it cannot accommodate significant deflection without breaking. Piping systems with flexibility and joint restraint are necessary to maintain continuous service when PGD of two inches or greater is anticipated. Site specific geotechnical investigations should be required to estimate the magnitude of ground movement before PVC can be approved for use. All new PVC sewer pipe with unrestrained joints shall include a geotextile "sock" to wrap around the pipe exterior at each joint. The geotextile will reduce the amount of soil entering the system if joint pull-out does occur.

HDPE or DIP with restrained joints or seismic joints can be selected and designed to maintain performance in areas where liquefaction settlement, lateral spreading, or seismic induced landslides are anticipated to cause PGD greater than two inches in magnitude. The City's Public Works Standards should be updated to indicate seismic hazard zones where additional seismic evaluation will be required to select the appropriate pipe materials to maintain operations following a seismic event in accordance with the LOS goals. The seismic risk categories identified in the previous section can be used for establishing the appropriate pipe materials for replacement of existing sewers or for installation of new sewers, but a localized geotechnical investigation should be required in high-risk areas to better understand the potential for PGD prior to pipe material selection. A summary of the recommended updates to the standards is identified in Table 9-6 below.

**Table 9-6: Updates to Public Works Standards**

Seismic Risk Category	Recommended Pipe Materials	Geotechnical Study Required
High	Fused HDPE or DIP w/ Seismic Joints	Yes
Medium	Fused HDPE or DIP w/ Restrained Joints or PVC	Yes
Low	Current Standards (PVC)	No
None	Current Standards (PVC)	No

### 9.1.6.3 Pump Station Upgrades

To fully achieve the LOS following a seismic event, upgrades will be required for the three pump stations that currently comprise the backbone system. Similar to the programmatic replacements described for pipelines in Section 9.1.6.1, these upgrades could be scheduled to coincide with major pump station upgrade projects to improve the cost-effectiveness of the repairs. The typical life of most major mechanical and electrical components within sewer pump stations is between 20 to 25 years, so implementing the recommended seismic mitigation measures along with a refurbishment or replacement project would provide the necessary improvements to the backbone system within the 50-year timeline identified in the Oregon Resilience Plan. The recommended improvements for each of the three stations is provided in Table 9-7 below.

**Table 9-7: Recommended Seismic Resilience Pump Station Projects**

Resilience Project	Pump Station	Recommended Improvements
R-1	Island PS (S1)	Full Station Replacement to Modern Seismic Code
R-2	Home and Monroe (S3)	Minor Retrofit per Table 9-4
R-3	Brookside (S5)	Minor Retrofit per Table 9-4

## 9.2 Climate Resilience

In 2018, the City adopted their first Climate Action Plan to minimize the impacts of climate change and increase the climate resilience of the City. The WWSMP will incorporate aspects of the Climate Action Plan that further the City's climate goals as they pertain to the wastewater system. Areas of focus for the wastewater system include the risk of sea level rise impacting the wastewater collection system, land use modifications to promote densification around hubs and corridors, urban tree planting, and potential modifications to engineering and construction standards to improve climate resilience and reduce greenhouse gas emissions.

### 9.2.1 Sea Level Rise

The City is bordered by the Willamette River to the west, which is a tidally influenced river, and thus subject to sea level rise. To evaluate the potential impact on the City's system, WSC utilized Climate Central's Coastal Risk Screening Tool to approximate the possible extents of flooding caused by sea level rise and increased storm intensities due to climate change. The parameters chosen for this analysis are shown in Table 9-8 and generally represent a conservative estimate of the impacts of sea level rise on the City over the next 50 years.



**Table 9-8: Sea Level Rise Tool Parameters**

Parameter	Setting	Reason for Choice
Year	2070	50-Year Planning Period
Projection Type	Sea Level Rise + 100-Year Flood	The 100-Year Flood is the design standard adopted by FEMA for flooding. This option pairs this level of flooding with Sea Level Rise projections.
Pollution Scenario	Unchecked Pollution	Assumes the annual global carbon emissions continue to climb for the remainder of the century, resulting in a 3°-4°F warming. This is the most conservative scenario.
Luck	Medium	This is an estimate of the impact greenhouse gases play on sea levels. Good luck indicates greenhouse gases have weaker effects than scientists generally expect while bad luck indicates a greater effect.
Sea-Level-Projection Source	Pessimistic	This uses the latest climate research that builds on previous studies by adding the possibility of early-onset decay of the West Antarctic Ice Sheet. It is the most conservative option.

The output of the Coastal Risk Screening Tool is shown in Figure 9-9. Areas shown in red represent areas that are expected to be impacted by sea level rise and a 100-year recurrence interval flood. The majority of the City's collection system assets are at much higher elevations relative to the Willamette River, however some of the most critical assets are located in areas that may be impacted. The manhole rims for trunk sewers within Milwaukie Bay Park and the inverted siphon crossing beneath Johnson Creek may be below the floodwater elevations. The massive inflow of surface water into the sewer system at these locations would likely overwhelm the capacity of the sewer collection and treatment system causing sanitary sewer overflows and contamination of the surface waters. Although not owned by the City, the Kellogg Creek WRRF owned and operated by WES may also be inundated by a large flood event coupled with sea level rise.

Based on the screening tool, WSC recommends improvements to the existing impacted manholes. To prevent the manhole covers from being displaced by flood waters and allowing massive inflow of surface water into the collection system, the City could replace the existing covers and frames with watertight assemblies. The watertight assembly allows the removable cover to be bolted to the frame and use a rubber gasket to create a watertight barrier that can prevent surface water from entering the sewer even if the water surface level is several feet above the manhole rim elevation. Locations of the manholes to be retrofit are identified in Figure 9-10 and Table 9-9. Collection sewer pipes in these areas are located well below ground surface and are not anticipated to be impacted by floodwaters or minor erosion of banks, however further analysis of bank stability would be required to determine if there is a risk of major erosion or bank failure.



**Table 9-9: Recommended Climate Resilience Projects**

Project	Recommended Improvement
R-4	Install bolted manhole frames and covers at the following manholes: <ul style="list-style-type: none"><li data-bbox="386 352 732 384">➤ 801 through 805 and 807</li><li data-bbox="386 388 1000 420">➤ 1002 through 1006, 1008, 1010, 1011, and 1015</li><li data-bbox="386 424 553 455">➤ CCMH036</li></ul>



Figure 9-9: Sea Level Rise Impacts on the City of Milwaukie (24)



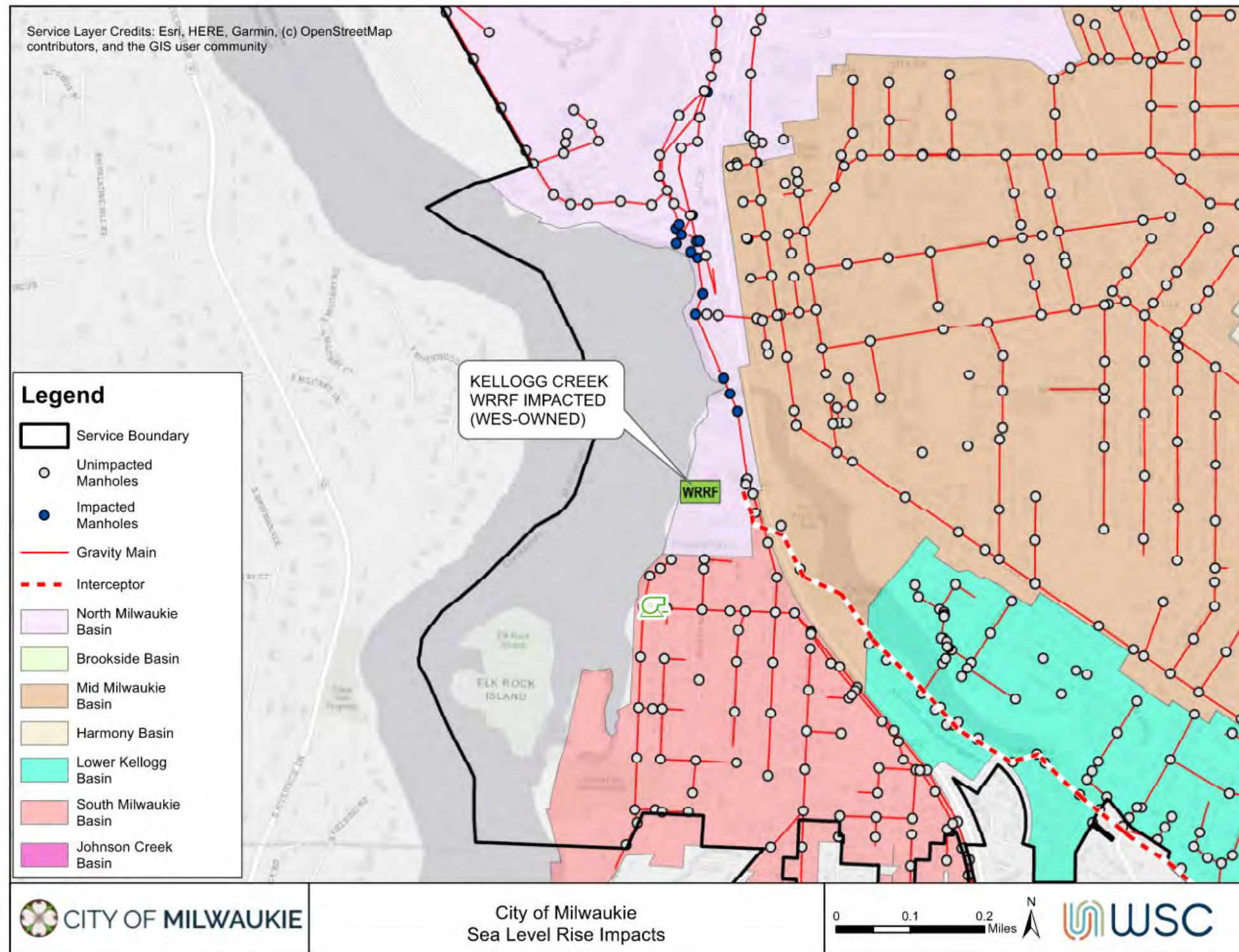


Figure 9-10: Collection System Infrastructure Impacted By Sea Level Rise

### 9.2.2 Climate Impacts from Growth

This master plan uses the City's "Hubs and Corridors" growth scenario for evaluating the impact of population growth on the City's collection system. The Hubs and Corridors scenario assumes greater densification along areas adjacent to high-frequency transit corridors and the hubs where those corridors intersect. By using this projection, the master plan is incorporating a greater reliance on public transportation and the resulting reduction in greenhouse gas emissions, which is consistent with the City's Climate Action Plan.

### 9.2.3 Urban Tree Planting

The City has defined an action within the Climate Action Plan to increase the tree canopy to 40 percent by 2040. A 2014 assessment estimated that the tree canopy coverage was 26 percent. Although this action will reduce greenhouse gases by providing shade and sequestering carbon, there may also be benefits to the wastewater system. The United States Environmental Protection Agency has provided guidance that Street Tree programs can reduce the volume of stormwater runoff (25) which can subsequently reduce the amount of infiltration and inflow in sewer collection piping. Care must be taken however in designating tree planting locations with sufficient separation from sewer mains and laterals such that growing tree roots do not cause damage to buried sewer pipes. Tree planting standards should include field marking of all mains and laterals so that planting locations will provide sufficient separation for the tree to reach its anticipated adult size without its dripline overhanging any pipeline alignments. Consultation with an arborist is recommended to determine appropriate spacing.

### 9.2.4 Climate Related Design Standards

The City could consider modifying their engineering and design standards to include climate-resilient policies to help them achieve the objectives outlined in their Climate Action Plan. Below is a list of preliminary standards the City could implement to improve climate resilience.

- **Concrete Pipe Recycling** - The City could mandate all concrete pipe be recycled at the end of its useful life. The concrete can be crushed and used in aggregate base. The reinforcing steel can be reclaimed by a recycling plant to be used in future steel products.
- **Reusable Material Mandate** – The City could impose a mandate that new construction within the City must use a certain percentage of reusable materials. For the wastewater collection system, this could include a mandate to utilize recycled concrete for pipe bedding or road base material. Additionally, recycled asphalt paving could be required for use in pavement patching.



- **Pipe Sustainability** – The City’s current sanitary sewer design standards call for new sanitary sewers to be constructed of PVC pipe. Recent studies on pipe material sustainability indicate that PVC is one of the most sustainable materials when evaluated on a life cycle basis. The life cycle analysis consists of evaluating the pipe for economic factors (capital cost, maintenance costs, disposal costs) and environmental factors (embodied energy and emissions during fabrication). A study by Akhtar et al evaluated concrete, PVC, ductile iron, and vitrified clay on a life cycle basis using two different life cycle methods. The methods concluded PVC and concrete pipe were the most sustainable but the top choice varied depending on the life cycle method used. (26) Sustainable Solutions Corporation evaluated HDPE in addition to concrete, PVC, ductile iron, and vitrified clay and concluded PVC pipe was the most sustainable. (27) Based on the results of these studies, WSC recommends the City continue to standardize on PVC pipe for new sewer pipelines. As new pipe technologies are developed, they should be evaluated relative to PVC pipe for overall sustainability.
- **Trenchless Repair Standards** – The City could standardize on using trenchless rehabilitation methods for repairing aging sewer pipelines whenever possible. CIPP or spiral wound PVC liners both rehabilitate mains without significant voids or offsets to restore hydraulic capacity. These liners are installed faster than digging and replacing the pipe and offer environmental benefits by reducing the emissions associated with excavation equipment. When upsizing is required, pipe bursting can be used to eliminate excavation and minimize environmental impacts. CIPP liners are anticipated to provide a design life of 50 years, with much longer lifetimes possible (28).
- **Energy Efficiency Standards** – Sewer pump stations should be evaluated for pump efficiency. To maximize energy efficiency, the pump should operate as close to its best efficiency point as possible and discharge rates should always be within 30% of the best efficiency capacity of the pump (discharge rate at best efficiency point). For pump stations with flatter pump curves, variable frequency drives could be installed to allow the pump to operate at a reduced speed, reducing friction losses which in turn improves energy efficiency.

CHAPTER 10

# Capital Improvement Program

Previous chapters of this WWSMP have identified improvement projects that address hydraulic capacity deficiencies, condition of aging infrastructure, and risks posed by seismic events and climate change. The purpose of this chapter is to recommend a wastewater system CIP over the twenty-year planning horizon that includes a schedule for implementation and financing for construction of improvements. The following sections describe the methodology for estimating project costs and prioritization, a recommended implementation plan, brief descriptions of individual projects and plans, and a recommendation for financing through customer rates and system development charges.

## 10.1 Methodology

The following sections describe the basis and assumptions used to develop cost estimates for recommended projects, a brief summary of the calculations used to identify SDC eligible costs, and the criteria used to prioritize individual projects within the CIP.

---

### IN THIS SECTION

- Methodology
- Recommended CIP
- Capital Improvement Projects
- Funding and Financing Summary

---

### 10.1.1 Cost Estimating Basis and Assumptions

Engineering opinion of probable construction costs (estimates) have been developed for each of the projects identified in previous chapters. The design concepts and associated costs presented in this CIP are conceptual in nature due to the limited design information that is available at this stage of project planning. For pipeline replacement projects, City GIS data was used to estimate quantities for pipeline length, depth, services, and pavement restoration. The scope of work for non-pipeline projects and studies were approximated based on equipment and/or facility size and comparison with similar replacement projects. As each project progresses into design and construction, the associated costs may vary as project-specific requirements are identified.

All estimates provided in this chapter were prepared in conformance with the Class 5 Opinion of Probable Construction Costs as developed by the Association for the Advancement of Cost Engineering for projects that have been developed to a conceptual report level. The purpose of a Class 5 Estimate is to provide a conceptual cost that can be used in budgetary planning. The expected range in accuracy of a Class 5 estimate is from -20 percent to -50 percent low and +30 percent to 100 percent high and is typically developed through analogy to costs from similar construction, judgment, and parametric models. To account for the limited accuracy, each project cost estimate also includes an appropriate level of contingency to account for additional costs that cannot be identified at the conceptual phase of a project. These cost estimates are based on unit costs developed using a combination of data from RS Means CostWorks® and recent bids, experience with similar projects, and foreseeable regulatory requirements. Costs are tied to an Engineering News Record (ENR) Construction Cost Index (CCI) of 11989.91. The ENR CCI can be used to adjust projected future costs based on monthly updates to the CCI.

For budgeting purposes, the construction cost estimates were adjusted to account for contingency to capture unknown aspects of the work at the planning stage and for the “soft costs” required to plan, design, and manage each project through construction. Adjustments to each project estimate were made using the following markups:

- A 30 percent markup of the itemized construction sub-total was added to account for construction contingency and unforeseen work items
- A 30 percent markup of the total construction cost including contingency was added to account for project development services including project administration, planning, alternatives analysis, engineering design, surveying, permitting, construction administration, inspection, materials testing, etc.

Detailed cost estimates are included in Appendix J.

### 10.1.2 System Development Charges

ORS 223.297 to 223.314 authorize the City to establish SDCs to recover a fair share of the cost of existing and planned facilities that provide capacity to serve future growth. The SDC is a one-time fee on new development that is paid prior to connection to the wastewater collection system.

To calculate an SDC for the City’s collection system, improvement and reimbursement costs can be considered. Improvement costs include those portions of future costs that will provide increased capacity that could serve new connections. Reimbursement costs include the eligible costs for existing facilities associated with the unused capacity that could benefit new connections. The eligible costs are divided by the number of equivalent dwelling units (EDU) of anticipated growth in the City through 2040. One EDU equals the wastewater flow of a typical single-family dwelling unit, which has been defined as 115 gpd of wastewater flow. A detailed description of the SDC methodology can be found in a technical memorandum prepared by FCS group and included as Appendix K. This technical memorandum calculates a recommended SDC using the incremental cost of increasing the capacity of the system for improvement costs and the percentage of excess capacity within the existing systems for determining reimbursable costs. The calculated SDC for the collection system is \$1,065/EDU. WES charges an SDC of \$8,120/EDU for wastewater treatment, bringing the total wastewater SDC for the City to \$9,185/EDU.

The City is considering the adoption of an SDC schedule for single-family homes that would allow for varying SDCs based on the square-footage and type of structure. Auxiliary dwelling units or homes with a square footage less than 1,800 square feet would have a lower SDC while homes above 3,000 square feet would require a slightly higher SDC. A schedule based on square footage is being considered to encourage infill development in accordance with “Hubs and Corridors” growth scenario established in the City’s Comprehensive Plan. A similar schedule is currently under consideration by WES for the wastewater treatment SDC.

### 10.1.3 Project Scheduling and Prioritization

In addition to developing a cost estimate for each project and determining the SDC eligible costs, the timing of each project was considered. Timing was determined using one of four possible criteria:

- **City Determined Frequency.** Where applicable, the City has provided a desired frequency for upgrades, replacements, or updates and the timing of projects was set accordingly. Projects identified in the City’s current 2021-2026 CIP as being funded through either the Wastewater Fund or the Wastewater SDC Fund were included without any adjustment to timing or budget.
- **End of Useful Life.** Refurbishment or replacement of assets is timed to occur as close as possible to the anticipated end of useful service life based on the typical expected life of an asset or type of refurbishment (i.e., internal lining, etc.) and the date of original installation or last refurbishment.
- **Coordination with SAFE Program.** The City’s SAFE program is working towards improving safety for pedestrians within the City by improving and/or adding sidewalks, ramps, crossings, and network gaps that comply with ADA standards. Many of the SAFE Program projects include repaving the streets around these safety improvements. The City imposes a 5-year moratorium on trenching or excavation within newly paved roads, and sewer main replacement projects were prioritized to occur prior to any planned paving.
- **Prioritization Criteria.** Those projects that do not fit the first three categories, were prioritized based on risk, as determined by the consequence and the likelihood of failure. Consequence of failure and likelihood of failure scoring was discussed in Chapter 8.



## 10.2 Recommended Capital Improvement Program

Using the scheduling, prioritization and cost estimating methodology described in the previous sections, a plan was developed to determine the annual capital spending required to address deficiencies within the wastewater collection system over the 20-year planning period. Project timing was adjusted to keep the annual capital costs as consistent as possible to avoid spikes in spending that could require large rate increases or debt-financing. A detailed spending plan is provided for the initial 10 years through fiscal year 2032. Projects that are lower priority or that are less understood are for future allocation in fiscal years 2033 through 2042. A more detailed planning for these lower priority projects will be reflected in future master plan updates. The recommended CIP plan is provided in Table 10-1.

A total of approximately \$25.6M in capital improvements was identified for the wastewater collection system.

In current dollars, the average annual capital spending would be \$1.3M per year over the 20-year planning period and \$1.6M per year over the first 10 years. Average annual spending is in accordance with the current FY21-FY26 budget, which averages \$1.5M in Wastewater Fund spending during the 6-year period. As the funding of the current wastewater CIP budget is provided through revenues generated by the wastewater fund and incremental rate increases, the proposed CIP is not anticipated to require significant rate increases or debt financing. The recommended year for implementing each improvement was established using the methodology described in Section 10.1.3 above. Some projects were separated into multiple phases across two or more fiscal years to keep the annual average capital spending as consistent as possible

## 10.3 Capital Improvement Projects

The following sections provide a brief description of each of the prioritized CIP projects including engineering and planning studies, fire flow improvements, resiliency, and condition driven projects. All CIP projects are also identified on a system map provided as a plate in Appendix L.

### 10.3.1 Capacity Projects

A total of four hydraulic capacity improvement projects were identified as part of this WWSMP. CAP-1, CAP-2, and CAP 3 were identified as part of the hydraulic modeling analysis and are described in Chapter 7. Table 7-13 provides a description of the scope for these three projects. CAP-4 (Harvey Street Improvements) is a project that was previously identified by the City outside of the master planning process and is included in the current CIP (FY 21 – FY 26) as part of planned SAFE project work. This project will provide a pipe stub out to the right-of-way to the Willamette Townhouse Apartments to allow for a future connection.

**Table 10-1. Capital Improvement Program Implementation**

Project ID	Description	Project Total (FY 2022 Dollars)	CIP Value in FY22 Dollars										
			FY22	FY23	FY24	FY25	FY26	FY27	FY28	FY29	FY30	FY31	FY32-41
			1	2	3	4	5	6	7	8	9	10	11-20
<b>Capacity (CAP) Projects</b>													
CAP-1	Manhole Surveying	\$475,000		\$25,000	\$25,000	\$25,000	\$25,000	\$25,000	\$25,000	\$25,000	\$25,000	\$25,000	\$250,000
CAP-2	Pipe Upgrades	\$819,000								\$819,000			
CAP-3	Flow Monitoring	\$124,000					\$31,000					\$31,000	\$62,000
CAP-4	Harvey Street Improvements	\$5,000	\$5,000										
<b>Condition (C) Projects</b>													
C-1	Pipeline Rehabilitation and Replacement	\$11,928,000		\$381,000	\$381,000	\$381,000	\$381,000	\$792,000	\$792,000	\$792,000	\$792,000	\$792,000	\$6,440,000
C-2	Pump Station Condition Assessments	\$30,000		\$30,000									
C-3 thru 7	Pump Station Improvements	\$3,408,000					\$213,000	\$213,000	\$213,000	\$213,000	\$213,000	\$213,000	\$2,130,000
C-8	Johnson Creek Siphon Inspection	\$100,000					\$100,000						
C-9	Waverly Heights Sewer System Reconfiguration	\$3,404,000		\$400,000	\$1,563,000	\$1,441,000							
C-10	Waverly South	\$91,000		\$91,000									
C-11	SCADA Design & Construction	\$105,000	\$105,000										
C-12	Ardenwald North Improvements	\$476,000	\$476,000										
C-13	Milwaukie/El Puente SRTS Improvements	\$522,000	\$257,000	\$265,000									
C-14	Logus Road & 40th Ave Improvements	\$149,000	\$5,000	\$144,000									
C-15	Wastewater System Improvements FY2023	\$491,000		\$491,000									
C-16	International Way Improvements	\$144,000			\$144,000								
C-17	North Milwaukie Improvements	\$465,000				\$465,000							
C-18	SAFE & SSMP FY 2025 Improvements - Park/Lloyd/Stanley	\$139,000				\$139,000							
C-19	Vehicle Purchases	\$752,000	\$635,000	\$102,000	\$15,000								
C-20	Lift Station Pump & SCADA Controls Replacement	\$200,000	\$50,000	\$50,000	\$50,000	\$50,000							
C-21	Wastewater Capital Maintenance Program	\$1,000,000	\$50,000	\$50,000	\$50,000	\$50,000	\$50,000	\$50,000	\$50,000	\$50,000	\$50,000	\$50,000	\$500,000
<b>Resilience (R) Projects</b>													
R-1	S1 Island Pump Station Rebuild	Included in C-8 thru C-12											
R-2	S3 Home & Monroe Pump Station Retrofit	Included in C-8 thru C-12											
R-3	S5 Brookside Pump Station Retrofit and Pump Upgrade	Included in C-8 thru C-12											
R-4	Bolted Manholes	\$13,000						\$13,000					
<b>Planning (P) Projects</b>													
P-1	Wastewater System Master Plan Update	\$800,000					\$200,000					\$200,000	\$400,000
<b>Total</b>		<b>\$25,640,000</b>	<b>\$1,583,000</b>	<b>\$2,029,000</b>	<b>\$2,228,000</b>	<b>\$2,551,000</b>	<b>\$1,000,000</b>	<b>\$1,093,000</b>	<b>\$1,080,000</b>	<b>\$1,899,000</b>	<b>\$1,080,000</b>	<b>\$1,311,000</b>	<b>\$9,786,000</b>

Note: The City's fiscal year runs from July 1 – June 30. The 2022 fiscal year begins on July 1, 2021. Project costs are rounded to the nearest \$1,000. All costs are based on an Engineering News and Review 20-City Average Construction Cost Index of 11989.91 for May 2021.

### 10.3.2 Condition Projects

A total of 21 condition projects are included in the CIP, 9 of which were identified as part of this WWSMP. Projects were divided into three categories: pipeline replacement and rehabilitation, pump station improvements, and previously identified City projects. Pipeline replacement and rehabilitation projects (C-1) are anticipated to occur every year, based on a risk-based prioritization system, and are discussed in detail in Chapter 8.

Pump station improvement projects (C-3 through C-7) represent various repairs, refurbishments or replacements to pumps, motors, and electrical equipment as these components reach the end of their useful life. Condition assessments of each pump station (project C-2) are recommended to be completed to refine the scope of improvements and to identify a timeline for those repairs. For the purposes of budgeting, improvement costs were estimated for each pump station based on available maintenance records and assumed useful life, as discussed in Chapter 8. The total cost for all pump station improvements was divided evenly over a ten-year period to provide the City flexibility in making repairs identified as part of the condition assessments. This work is scheduled to begin in FY 26 to avoid large increases in the City's annual budget. The remaining projects were previously identified by City staff outside of this WWSMP. Project C-8 and C-9 are carried over from the 2010 WWSMP as described in Chapter 8. Projects C-10 through C-21 are all identified within the City's current CIP (FY 21 – FY 26) and consist of condition-based sewer pipeline improvements within the extents of planned street and sidewalk improvements within SAFE projects.

### 10.3.3 Resilience Projects

A detailed analysis of the seismic vulnerability of the City's sewer system is provided in Chapter 9 of this WWSMP. As described in Chapter 9, three pump stations were evaluated for seismic risk and projects were identified for rebuilding or retrofitting these stations to comply with the latest seismic code. The cost for these three pump station projects (R-1 through R-3) are incorporated into the costs for the pump station improvement projects (C-3 through C-7) as the seismic improvements will likely be done simultaneously with other work at these stations. The final resilience project (R-4) will implement bolted manhole lids on manholes near the Willamette River that could be impacted by sea level rise. More information on this project is included in Chapter 9.

### 10.3.4 Planning Projects

Planning capital improvements beyond five years can be a challenge for wastewater utilities, and a targeted update to the master plan on a five-year cycle can dramatically improve the utility of the WWSMP. Project P-1 allocates budget every five years to provide an update to this WWSMP to facilitate future CIP development and reflect improvements made within the City's collection system.

## 10.4 Funding and Financing

The City has several options to fund the CIP including user fees, bonds, grants from outside agencies, and SDCs. The following sections will describe the potential for funding the recommended capital improvements through user fees and SDCs, bonds, or grants from outside agencies.

### 10.4.1 Rates and SDCs

The City currently funds the wastewater CIP through rates and SDCs. In the adopted biennial budget for FY21-FY22, capital spending of \$3.4M (or \$1.7M per year) is adequately funded through the current rates, fees, and charges. With the proposed CIP in this WWSMP recommending average annual spending of a similar magnitude, funding could reasonably be provided through existing rates and SDCs.

### 10.4.2 Bonds

Debt financing of capital improvements through issuance of revenue bonds is common practice, but typically will incur a higher interest rate than low-interest government loans. The adopted FY21-22 City budget indicates that the wastewater fund currently budgets for \$204,000 per biennium in debt service, which is a relatively small portion of the overall \$20,619,000 budget for spending. Issuance of public debt could be considered if expediting the implementation of the CIP is desired as there may be capacity to take on additional debt service. At the time of writing of this WWSMP, there does not appear to be a significant driver for expediting the implementation of the CIP.

### 10.4.3 Grants and Loans

As an alternative to bond financing, there are several state and federal programs that offer low-interest financing. Projects meeting certain criteria may also qualify for loan forgiveness or grant funding. Several potential programs are listed below and could be considered for funding specific capital improvements:

- **Clean Water State Revolving Fund (CWSRF):** The CWSRF is managed through the Oregon DEQ and provides loans with below market rates. Loans can be used for wastewater system improvements, including designing and planning costs, with no limit on total project cost. Projects approved for funding must begin within two years of receiving the funding agreement.
- **Water/Wastewater Financing Program:** The water/wastewater financing program is managed through Business Oregon Infrastructure Finance Authority and provides low interest loans and occasionally grants to municipalities for compliance with the Safe Drinking Water Act and Clean Water Act. Loans can be used for wastewater system improvements, including design and planning costs, up to \$10,000,000 per project.
- **Federal Emergency Management Agency Pre-Disaster Mitigation Loans.** Projects for mitigating seismic risk can be eligible for this program but must be consistent with the goals and objectives identified within the County's NHMP.



- **Clackamas WES Regional Infiltration & Inflow Partnership.** WES is offering funding for thirty-three percent (33%) of all qualifying RDII reduction projects within the next three (3) years as part of a pilot period. Qualifying RDII reduction projects within the City’s Brookside, North Milwaukie, Mid-Milwaukie, or South-Milwaukie basins overlap with WES’ Milwaukie Basin which is one of the 19 identified sub-basins within the program.

## 10.5 Summary

The recommended CIP identifies approximately \$25.6M in projects, with roughly 60% of the work to be completed within the next 10 years. An implementation schedule that provides for an average capital improvement budget of \$1.6M per year for the next 10 years appears feasible and may be accomplished with moderate rate increases similar to those implemented by the City over previous years. Prioritization of projects is based upon the currently known deficiencies within the system but as continued inspections and assessments of sewers, manholes, pump stations, and siphons provide new information there may be a need to adjust the prioritization and timing of the CIP. However, if there is a desire to accelerate the improvement schedules, bond or government low-interest financing can be pursued.

## CHAPTER 11

# References

1. **CH2M Hill.** *Sewerage Facilities Plan City of Milwaukie.* Milwaukie : s.n., 1994.
2. **Jacobs, Murraysmith, Century West Engineering.** *Sanitary Sewer System Master Plan for Water Environment Services.* 2019.
3. **City of Milwaukie City Council.** *Council Resolution No. 7-2020 - Endorsing the Declaration of a Climate Emergency and Emergency Mobilization Effort to Restore a Safe Climate.* Milwaukie : s.n., 2020.
4. **USGS.** The National Map. *USGS National Map.* [Online] USGS, October 22, 2018. [Cited: June 06, 2019.] <https://viewer.nationalmap.gov/advanced-viewer/>.
5. **Arnfield, A. John.** Köppen Climate Classification. *Encyclopaedia Britannica.* [Online] Encyclopaedia Britannica, Inc., 04 11, 2019. [Cited: 08 19, 2019.] <https://www.britannica.com/science/Koppen-climate-classification>.
6. **The Weather Channel.** Almanac - Portland Metro Area . *The Weather Channel.* [Online] The Weather Channel, 2019. [Cited: 08 19, 2019.] <https://weather.com/weather/monthly/l/801bce215e44a454e139c9b02868725618bdf3cf7136ced0c18d90b65652cc44>.
7. **United States Census.** *City and Town Population Totals: 2010 - 2019.* 2019.
8. **City of Milwaukie.** *Milwaukie Community Facts (2016-2017).* 2017.
9. —. City of Milwaukie Web Maps - Public Works - Wastewater. *City of Milwaukie.* [Online] City of Milwaukie, 2019. [Cited: July 2, 2019.] <https://milwaukie.maps.arcgis.com/apps/MapJournal/index.html?appid=6a1a77c426d74bda80d3620a60ae3fd3#>.
10. **Parametrix.** *2010 Wastewater Master Plan.* Milwaukie : s.n., 2011.
11. **State of Oregon.** Oregon Administrative Rule, Chapter 660, Division 11. *Public Facilities Planning.*
12. *Certified 2020 Population Estimates.* **Portland State University Population Research Center.** Portland : s.n., 2020.
13. *2040 Household Distributed Forecast.* **Oregon Metro.** 2016.

14. **Milwaukie, City of.** *Comprehensive Plan*. 2020.
15. *A Toolbox for Sanitary Sewer Overflow Analysis and Planning (SSOAP) and Applications*. **Fu-hsiung Lai, Srinivas Vallabhaneni, Carl Chan, Edward H. Burgess, Richard Field**. s.l. : U.S. Environmental Protection Agency.
16. *Gettrng More From Flow Monitoring - Interpreting Sewer Flow Data to Yield the Maximum Benefit*. **Paul S. Mitchell, P.E. and Patrick L. Stevens, P.E.** Huntington Beach, CA : Water Environment Federation, 2005, Vols. Collection Systems 2005 - Sustaining Aging Infrastructure: System, Workforce, and Funding.
17. *Stormwater Master Plan*. **Brown and Caldwell**. Milwaukie : s.n., 2014.
18. **Oregon Lidar Consortium**. Collecting LIDAR. *State of Oregon Department of Geology and Mineral Industries*. [Online] 2016.
19. **CH2M Hill**. *55th Avenue Sanitary Sewer Pump Station Operation and Maintenance Manual*. 2011.
20. **Jabobs Engineering; Murraysmith; Century West Engineering**. *Sanitary Sewer System Master Plan for Water Environment Services*. 2019.
21. **Environmental Protection Agency**. *Condition Assessment of Underground Pipes*. April 2015.
22. **SEFT**. *Technical Memorandum: Level of Service Goals, Performance Objectives, and Wastewater System Backboneq*. Milwaukie : s.n., 2020.
23. **Liu, Melanie, Giovinazzi, Sonia and Lee, Pedro Jose**. *Seismic Fragility Functions for Sewerage Pipelines*. s.l. : ASCE Pipelines Conference, 2015.
24. **Climate Central**. Coastal Risk Screening Tool - Land Projected to Be Below 100-Year Flood Level in 2070. *Climate Central*. [Online] 2020. [Cited: July 23, 2020.] [https://coastal.climatecentral.org/map/13/-122.6304/45.442/?theme=sea\\_level\\_rise&map\\_type=year&contiguous=true&elevation\\_model=best\\_available&forecast\\_year=2070&pathway=rcp85&percentile=p50&return\\_level=return\\_level\\_100&slr\\_model=kopp\\_2017](https://coastal.climatecentral.org/map/13/-122.6304/45.442/?theme=sea_level_rise&map_type=year&contiguous=true&elevation_model=best_available&forecast_year=2070&pathway=rcp85&percentile=p50&return_level=return_level_100&slr_model=kopp_2017).
25. **U.S. Environmental Protection Agency**. *Stormwater to Street Trees: Engineering Urban Forests for Stormwater Management*. 2013.
26. **Sharmin Akhtar, Bahareh Reza, Kasun Hewage, Anjuman Shahriar, Amin Zargar, Rehan Sadiq**. *Life Cycle Sustainability Assessment (LCSA) for Selection of Sewer Pipe Materials*. 2014.
27. **Sustainable Solutions Corporation**. *Life Cycle Assessment of PVC Water and Sewer Pipe and Comparative Sustainability Analysis of Pipe Materials*. 2017.
28. **U.S. Environmental Protection Agency Office of Research and Development**. *National Database Structure for Life Cycle Performance Assessment of Water and Wastewater Rehabilitation Technologies (retrospective Evaluation)*. 2014.

29. **Oregon Metro.** *Regional Transportation Plan- Population, Employment, Households, and 2040 Design Type by Transportation Analysis Zone (TAZ).* 2018.



# Appendix A. Intergovernmental Agreement with Clackamas WES

# RECORDING MEMO

<input checked="" type="checkbox"/> Agreement
Amendment/Change Order Original Number _____
Policy, Reports, _____

ORIGINATING COUNTY  
DEPARTMENT:

Water Environment Services

PURCHASING FOR: N/A

OTHER PARTY: City of Milwaukie

Board Agenda Date: 12-6-12

Agenda Item Number: III. 1.

PURPOSE:

Approval of an Intergovernmental Agreement between Clackamas County and the City of Milwaukie for the Provision of Wastewater Treatment Services.

After Recording Please  
Return to Trista Crase, Water Environment Services

Clackamas County Official Records  
Sherry Hall, County Clerk  
Commissioners' Journals  
Agreements & Contracts

2012-4799

12/27/2012 09:00:01 AM

 ORIGINAL

INTERGOVERNMENTAL AGREEMENT  
BETWEEN  
CLACKAMAS COUNTY SERVICE DISTRICT NO. 1  
AND  
THE CITY OF MILWAUKIE  
FOR THE PROVISION  
OF WASTEWATER TREATMENT SERVICES

THIS INTERGOVERNMENTAL AGREEMENT FOR THE PROVISION OF WASTEWATER TREATMENT SERVICES (this "Agreement") is effective as of the 1<sup>st</sup> day of July, 2012 (the "Effective Date") by and between Clackamas County Service District No. 1, a county service district ("CCSD#1") and the City of Milwaukie, an Oregon municipality ("City"), each also individually referred to as "Party" and collectively as the "Parties."

**RECITALS**

WHEREAS, the Parties are authorized to enter into agreements regarding the provision of services to their residents, customers and service areas pursuant to their respective charter or principal acts and ORS 190.010; and

WHEREAS, the Parties share a substantial common boundary and interlinked wastewater systems; and

WHEREAS, CCSD#1 has provided wastewater treatment services for City since 1972 and is desirous to continue its relationship with the City; and

WHEREAS, the City has used CCSD#1 as its sewer treatment provider since 1972 and is desirous to continue its relationship with CCSD#1; and

WHEREAS, CCSD#1 and City are currently parties to a Memorandum of Understanding entered into May 17, 2012 (the "MOU") which outlines the primary terms and conditions for this Agreement and implements certain financial terms regarding the provision of wastewater treatment and related services to City by CCSD#1; and

WHEREAS, CCSD#1 and City desire to implement fully the terms of the MOU and enter into a new agreement to reflect a Wholesale treatment rate structure based on a per-equivalent dwelling unit basis; and

WHEREAS, the Parties desire to provide for public health and safety, compliance with state and federal environmental laws, coordination of statutes, ordinances, and methods of implementation; and application of codes, implementation, and enforcement practices;

**NOW THEREFORE**, the Parties hereby agree as follows:

**SECTION 1. DEFINITIONS**

1.1 “BCC” means the Board of County Commissioners of Clackamas County, acting as the governing body of CCSD#1.

1.2 “CCSD#1” means the Clackamas County Service District No. 1 or its successor, as such entity’s boundaries may be adjusted by annexation or other boundary actions from time to time.

1.3 “DEQ” means the Oregon State Department of Environmental Quality, or its successor.

1.4 “Domestic Sewage” means sanitary wastes normally collected from residential establishments, and shall include commercial and industrial wastes of similar strength to residential wastes or quality, and other commercial and/or industrial wastes that participate in an approved Industrial Pretreatment program in accordance with CCSD#1 and/or City requirements meeting DEQ and EPA guidelines. Domestic Sewage shall exclude ground water, storm water, drain water and industrial waste not pre-treated in accordance with CCSD#1 and/or City requirements meeting DEQ and EPA guidelines.

1.5 “EPA” means the United States Environmental Protection Agency, or its successor.

1.6 “Equivalent Dwelling Unit” or “EDU” is a unit of measure applied to a user of the sewage system as further defined in CCSD#1’s rules. For the purposes of this Agreement, the same definition shall always apply to CCSD#1 and City at any one time, and the Parties shall consult with each other regarding any proposed change to the Rules.

1.7 “Flow” means that certain volume of wastewater as measured by gallons per day that is delivered to a wastewater treatment system.

1.8 “Force Majeure Event” means each and any of war, insurrection, terrorism, strikes, walkouts, riots, floods, drought, earthquakes, fires, casualties, acts of God, governmental restrictions imposed or mandated by governmental entities other than the Parties, enactment of conflicting state or federal laws or regulations, new or supplementary environmental regulation, litigation or similar bases for excused performance that is not within reasonable control of the Party to be excused.

1.9 “I/I” means infiltration and inflow into a sewer system.

1.10 “Influent Points” means the points at which City’s Internal System intersects CCSD No.1’s Wholesale collection system.



1.11 “Industrial Pretreatment” means a program for qualified sewer users at the thresholds established in the Rules whereby the user is required to provide the appropriate level of pretreatment before discharging into the collection system of either Party for treatment by CCSD#1.

1.12 “Internal System” means all non-Wholesale sewer lines and other sewer facilities upstream from the Influent Points owned and operated by City.

1.13 “City” means the City of Milwaukie as such entity’s boundaries may be adjusted by annexation or other boundary actions from time to time.

1.14 “NPDES Permit” means a National Pollutant Discharge Elimination System Permit granted to CCSD No.1, pursuant to the Federal Water Pollution Control Act, as amended.

1.15 “Parties” means CCSD#1 and City.

1.16 “Prior IGAs” means each and all of those certain intergovernmental agreements dated November 3, 1969 as subsequently amended or supplemented from time to time and all subsequent IGAs regarding similar subject matter, most recently on December 17, 2002.

1.17 “Prime Rate” means the interest rate banks charge to large corporations for short-term loans, as published in the Wall Street Journal or other similar publication.

1.18 “Retail” means the provision of collection and conveyance piping, maintenance of the same and direct billing and collection to residential households.

1.19 “Rules” means the Rules and Regulations of CCSD#1, as such may be amended from time to time.

1.20 “SDCs” means system development charges as established in ORS 223.297 through ORS 223.314 or successor statutes. For the purposes of this Agreement, the City shall only be obligated to contribute an amount equal to that portion of CCSD#1’s SDCs relating to Wholesale treatment.

1.21 “Wholesale” means a systemic provision of wastewater treatment services via a wastewater treatment plant or other similar structure, excluding therefrom the general collection and conveyance system (e.g. piping and interceptors) necessary to deliver wastewater to a wastewater treatment plant. It may include certain interceptors established solely for the purpose of flow management between CCSD#1 treatment assets, such as the Intertie 1 and 2 pipelines, and Industrial Pretreatment programs.

For the purposes of this Agreement, terms used but not defined herein shall have the meaning ascribed to them in the Rules.

## **SECTION 2. SERVICES PROVIDED BY CCSD#1**

2.1 Wastewater Treatment Service. CCSD#1 shall receive, transport, and treat Domestic Sewage discharged by City on a Wholesale per-EDU basis. CCSD#1 shall accept such delivery and treat the wastewater in a manner consistent with the requirements of the Clean Water Act and all applicable state laws for the term of this Agreement.

2.2 Operation, Replacement, and Maintenance of Facilities. CCSD#1 shall be responsible for the operation, replacement and maintenance of all applicable wastewater treatment facilities. Such facilities shall be operated, replaced and maintained in accordance with generally accepted industry standards, and the standards established by the EPA, DEQ, the Oregon Health Department and other federal, state and local agencies.

2.3 Designation of Service Provider. The Parties agree that City shall provide and be responsible for all aspects of its Internal System, the collection (retail) sanitary sewer service and surface water management service and all other acts necessary, customary, and incidental to providing retail sewer service and to deliver all appropriate wastewater to the conveyance and treatment system of CCSD#1. CCSD#1 agrees to be the designated service provider for sewer treatment for the City for the purposes of land use goals.

2.4 Land Use. City and CCSD#1 agree that CCSD#1 will suffer no negative impact, fiscal or otherwise, from Comprehensive Plan Amendment CPA-06-01 or Zoning Ordinance Amendment ZA-06-01. In particular, the proposed amendment to Zoning Code Section 19.321.3 A seeks to prohibit sewage treatment plants in all zones within the City, including Kellogg, with a fine for continued existence being levied beginning in December 2015. To the extent CCSD#1 experiences any fines resulting from any of the above provisions or other Comp Plan or Zoning changes with a substantially similar goal of compelling removal of Kellogg, then CCSD#1 shall charge City for the costs regarding the same, including attorney's fees spent in defense.

## **SECTION 3. RATES**

3.1 Wholesale Rate. CCSD#1 shall assess a per-EDU wholesale rate to City equal to the Wholesale rate for in-district customers (the "Rate"). The Parties have agreed to a methodology to be utilized in calculating the Rate whereby the total costs of CCSD#1, including debt service, capital account requirements and other standard utility expenses are calculated, and then apportioned between Wholesale costs and Retail costs. CCSD#1 shall bill City monthly for the service based on a formula of the Rate multiplied by the number of EDUs served in City, and City shall remit payment within thirty (30) days. Late payments by City shall accrue an interest penalty of the Prime Rate annual rate, compounding monthly. Nothing contained herein shall be deemed a restriction or a limitation on City's ability to add such other charges to its customers as it deems appropriate. For the first year of this Agreement, City's Rate shall be \$30.21.

3.2 Modification of Rate. As part of its normal ratemaking process for CCSD#1, the BCC shall have the opportunity to adjust the Rate based on all factors the BCC considers material for making such a decision, including requirements for the maintenance, operation, anticipated capital expenditures, administration, overhead, expansion of CCSD#1's sewer treatment system, principal and interest payments, and reserve requirements or other financial covenants on any outstanding debt instruments. City shall have a representative on the District Advisory Board and will be consulted regarding any proposed Rate changes, including the ability to offer comments to the BCC prior to any adjustment. Any change of the Wholesale Rate shall be the same for both City EDUs and CCSD#1 EDUs.

3.3 Reporting Requirements. The Parties agree that the audit performed by GEL Oregon, Inc., which counted City's EDUs as 10,939 is a true and accurate statement of connections as of the Effective Date of this Agreement. The City shall deliver to CCSD#1 a written report stating the current number of connections to the City system and noting new connections and any permanent disconnections on March 1 and September 1 of each year. The Parties shall work together using the Rules to establish the number of EDUs to be assigned to new connections within the City.

3.4 Records. City shall maintain records of new connections to its sewer system, and CCSD#1 may review such records as such time as may be reasonably requested.

3.5 System Development Charges. City agrees that it shall pay the equivalent of the Wholesale SDC for all new connections from the Effective Date of this Agreement. CCSD#1 agrees that there are no SDC amounts due and owing for connections existing prior to or as of the Effective Date. Payments for such new connections shall be tendered semi-annually with the report of new connections described in Section 3.3 above. The City has received CCSD#1's SDC ordinance and the Parties agree that the Wholesale SDC shall be calculated pursuant to such ordinance. CCSD#1 shall not make any changes to the ordinance that apply to the City without consulting with and receiving the City's consent regarding any such changes. CCSD#1 shall bring forth the capital plans described in the ordinance to the Riverhealth Advisory Committee or successor entity for review and discussion prior to adoption.

3.6 Books and Accounts. City shall keep full and complete books of accounts showing the number of connections to its sewerage system, the maintenance and operation costs incurred in connection with the collection and conveyance system, its efforts to reduce "I/I" and otherwise comply with Sections 4.2 and 4.3, and its response to emergency and non-emergency spills or additions to the sewerage system. The costs of keeping those books shall be considered an operational cost to City.

3.7 Obligation to Pay. City acknowledges that the rate structure for CCSD#1 will be calculated in reliance on expected revenue from the City for services provided, and that failure of the City to pay would result in a material financial hardship and potential covenant violations of CCSD#1's outstanding revenue obligations. City agrees that it shall

promptly pay its charges when due, and that failure to pay is a material breach of this Agreement.

#### **SECTION 4. SYSTEM MANAGEMENT AND COORDINATION**

4.1 Coordination of Systems. CCSD#1 and City shall coordinate the operations of the wastewater collection, conveyance and treatment systems to optimize treatment and environmental benefits. In the event of plant distress, flash floods, excess infiltration and inflow, illegal materials delivered to the treatment system, or other similar event, CCSD#1 shall coordinate with City regarding the possible diversion, backup, transfer or other management option for the handling of wastewater flow. To the extent necessary, in CCSD#1's judgment, to insure compliance with NPDES Permit requirements, CCSD#1 staff may direct City staff to take such actions as are appropriate to avoid violation of NPDES Permit requirements, including but not limited to diversions, restrictions, cleanup or blocking efforts, or any other action reasonably necessary to avoid risks to human health or safety, any environmental damage including collection system overflows, or damage to the wastewater treatment facility's ability to treat wastewater.

4.2 Treatment of Domestic Sewage Only. City acknowledges and agrees that CCSD#1 shall only be required to treat Domestic Sewage. CCSD#1 may reject all non-conforming forms of wastewater, and may refuse to transport and/or treat Domestic Sewage from those portions of City's sewage collection system that do not conform to DEQ, EPA, or CCSD#1 standards for Domestic Sewage.

4.3 Pretreatment Ordinances. City has previously implemented a pre-treatment program consistent with the Rules, called the "City Pretreatment Program" (the "Program"). After due consultation with City staff, CCSD#1 may require changes to the Program to remain consistent with requirements imposed by state or federal law, the Rules, or its current best management practices for the Industrial Pretreatment program, and may include, but is not limited to: developing procedures, forms and instructions; categorizing dischargers; records keeping; compliance tracking; establishment of annual limits; sampling, testing and monitoring; preparation of control documents; enforcement, including collection of fees, penalties, and other extraordinary charges; and preparation of permits. Nothing contained herein shall obligate City to undertake program requirements greater than those imposed by CCSD#1 within its boundaries. The fees to be charged for Industrial Pretreatment shall be set by mutual discussion of the Parties, but in no case lower than those charged to Industrial Pretreatment customers within CCSD#1.

4.4 Rules and Regulations. City shall assure that its sewerage ordinances are consistent with and at least as effective as CCSD#1's Rules. CCSD#1 will provide due notice and consult with City staff regarding any substantive changes that may impact current City ordinances, beyond any general discussion at the advisory committee level.

4.5 City Internal System. City shall operate and maintain its Internal System at its sole expense, including all of its facilities as required to deliver the wastewater to CCSD#1's system or facility. City shall observe generally accepted standards and

practices in the construction, operation, replacement and maintenance of its Internal System, with particular attention to the following: (i) minimizing entry in the sewerage system of groundwater and/or I/I; (ii) maintaining a favorable character and quality of Domestic Sewage in accordance with the standards set forth in Section 4.2 hereof; (iii) eliminating septicity and objectionable odors, entry of petroleum waste or other chemicals and/or wastes detrimental to sewer lines, pumping stations, wastewater treatment plants, and the waters of the State of Oregon; (iv) eliminating hazardous and toxic wastes; and (v) maintaining an efficient and economical utility operation while achieving optimum pollution and environmental control. Nothing contained herein shall obligate City to undertake particular Internal System activities unless otherwise directed by a third party regulatory agency such as DEQ.

4.6 Mutual Notification. The Parties agree to provide each other with written notice of any condition that may violate this Agreement or applicable laws, regulations, or permits. The discharge Party agrees to give verbal notice to the other Party immediately upon becoming aware of the violating discharge. A written report on the nature and amount of the violating discharge will be prepared and provided to the other Party within twenty-four (24) hours of the time the violating discharge is identified. If the Party does not correct such a condition within a reasonable time of written notice thereof, the offending Party shall pay any reasonable and necessary costs and expenses incurred by the other Party in connection with such condition. If either Party discharged in to the wastewater system any solids, liquids, gases, toxic substances, or other substance that is reasonably believed to cause or will cause damage to the system, or is creating a public nuisance or a hazard to life or property, that Party shall discontinue the discharge of such substances. Because substandard condition of Domestic Sewage may cause serious damage to the wastewater treatment facilities, both Parties shall comply with generally accepted standards regarding the composition of Domestic Sewage, and after compliance, will work together to allocate the cost associated with necessary corrective actions.

4.7 Allocation of Penalty. The Parties shall cooperate with each other to determine the source of possible violations of applicable law, regulations and permits (including applicable NPDES Permits). In the event CCSD#1 is fined or otherwise penalized by local, state, or federal agencies for failure to operate or maintain the wastewater treatment system in accordance with the requirements of the agencies, and it is demonstrated to CCSD#1's and City's reasonable satisfaction that such violation or failure is due, in whole or in part, to City's discharge of Domestic Sewage in violation of this Agreement, then City shall pay its commensurate share of the costs of such fines or penalties, including its share of the associated administrative, legal, and engineering costs incurred by CCSD#1 in connection with these fines or penalties, including responses to or appeals thereof within 60 days of receiving written notice thereof. In the event that CCSD#1 and City cannot agree hereunder with regard to responsibility or shares, they shall resolve the issue(s) as provided in Section 5.3 herein.



4.8 Services Provided by City.

4.8.1 **Sanitary Sewer.** In any area now or hereafter becoming part of City, City shall provide all collection sewer services, billing and collection, inspection, and the like with respect to the sewer collection system. City shall have sole ownership and responsibility to operate, maintain, repair and replace facilities or to permit, design and construct collection sewer facilities, subject to Section 4.5. City shall have sole discretion as to the methods of financing such facilities, provided City insures compliance with Section 3.7 hereof. If within any area hereafter becoming part of City collection facilities exist that were built by CCSD#1, CCSD#1 and City will agree upon the manner and amount of compensation to be paid to CCSD#1 as a result of the transfer of those facilities to City. If they are unable to agree, the issue will be resolved pursuant to Section 5.3 herein.

4.8.2 **Surface Water Management.** City shall be solely responsible for all aspects of surface water management within its boundaries and to comply with the obligation imposed on it pursuant to the NPDES Permit, its MS4 Permit, and other applicable laws and regulations.

4.9 Services Provided by CCSD#1.

4.9.1 **Sanitary Sewer.** In any area now or hereafter becoming part of CCSD#1, CCSD#1 shall have sole ownership and responsibility to operate, maintain, repair and replace facilities or to permit, design and construct collection, conveyance, or treatment sewer facilities. CCSD#1 shall have sole discretion as to the methods of financing such facilities, but shall consult with City through the District Advisory Committee regarding anticipated capital projects, financings, rates, and other issues as normally discussed pursuant to the Riverhealth Advisory Board bylaws, as amended from time to time.

4.9.2 **Surface Water Management.** Unless otherwise agreed, CCSD#1 and City shall each be solely responsible for surface water management within their respective boundaries, and CCSD#1 shall not charge City for stormwater services.

4.9.3 **Laboratory Services.** CCSD#1 shall provide all laboratory services necessary to comply with all relevant regulatory requirements for Wholesale services. If desired by City, CCSD#1 will provide laboratory testing and results for City relating to Retail or stormwater tests pursuant to the laboratory services fee schedule attached hereto as Exhibit A, as such fee schedule may be updated from time to time, but no more frequently than annually. CCSD#1 agrees that City shall not be charged any per-test fee greater than that charged to other lab customers using similar services.

4.10 Peak Flow/I&I. The Parties agree on the importance of maintaining their conveyance infrastructure to avoid I/I problems. To that end the Parties agree that they will work cooperatively to respond and comply with any regulatory requirements imposed under the Clean Water Act on conveyance infrastructure. The Parties also

acknowledge that excessive I/I problems can lead to treatment failure at the Kellogg Plant, and that if the plant experiences two or more permit violations during a calendar year relating to excess flow as determined by the Operations Supervisor or Kellogg Plant Manager, then each Party shall conduct an investigation of their respective conveyance systems to identify and remedy I/I problems to ensure the plant maintains a peaking factor of no more than 4:1 above average dry weather flow.

**4.10.1 Mutual Investment in I/I Reduction.** CCSD#1 agrees to contribute ten percent (10%) of the City's costs for all wastewater conveyance infrastructure projects designed to reduce I/I within the City. To obtain this contribution, the City will provide CCSD#1 staff with an annual list of anticipated projects no later than February 15 for the next fiscal year beginning July 1, which will be evaluated by such staff for its impacts on I/I, as distinct from structural rehabilitation or service for growth. CCSD#1 staff shall provide a written response and evaluation of the Project no later than March 15 of the same year detailing how much of the project, in their opinion, relates to I/I mitigation. In the next fiscal year the City will, at its discretion, provide either copies of monthly invoices showing the expenses and requesting 10% reimbursement of the appropriate amounts of such projects, or one request for 10% of the approved costs at the end of such project, which CCSD#1 shall pay within thirty (30) days.

**4.11 Good Neighbor Fund & Efforts.** CCSD#1 shall establish a district fund and for the duration of this Agreement shall deposit monthly the equivalent of One and no/100 Dollars (\$1.00) per EDU of the City's connections as reported under Section 3.3 (the "Good Neighbor Fund"), after receipt of payment from the City for such month. The Good Neighbor Fund shall be used for the purpose of mitigating the impact of the Kellogg Plant on the surrounding neighborhoods, which may include, for example, buffer acquisitions and/or landscaping within 200 yards of the plant property line, improvements on the Kellogg Plant property, or neighborhood sewer infrastructure projects (a "Fund Approved Purpose"). City shall establish a process for developing and prioritizing projects and/or efforts to be undertaken with Good Neighbor Fund monies that will include participation by City citizen groups representing areas near the Kellogg Plant. CCSD#1 staff shall meet and assist in planning any intended uses for this fund, and will generally defer to the desires of the City as expressed by City staff for the uses of those funds. CCSD#1 staff shall make the final determination if the proposed use of the monies is consistent with the purposes of the Good Neighbor Fund as expressed in this section subject to Section 5.3 herein.

At the City's discretion, it may request that up to eighty percent (80%) of the monthly revenues deposited into the Good Neighbor Fund as described in this Section 4.11 be remitted to the City's sewer utility fund to support debt service payments for certain capital projects. CCSD#1 shall grant such a request so long as (i) the remitted revenues will support a project that is a Fund Approved Purpose; (ii) that, in the reasonable opinion of CCSD#1 staff, the proposed project will not violate the legal authority of the district's authorizing statutes; and (iii) the Parties shall reach agreement regarding the future ownership and/or maintenance of the resulting capital project. This

remittance shall continue only for so long as the length of the loan or other financing undertaken at the time of the request to accomplish the Fund Approved Purpose project proposed to CCSD#1.

**4.11.1 City Report & Neighborhood Groups.** CCSD#1 staff will attend neighborhood meetings at least every other month for both of the Island Station and Historic Milwaukie neighborhood associations. By July 1 of each year, CCSD#1 staff will provide an annual report to the Milwaukie City Council and Citizens Utility Advisory Board regarding communication with the neighborhood groups and a summary of the budget and Rate decisions made by the BCC for the coming fiscal year.

**4.12 Odor Control.** CCSD#1 shall contribute One Million and No/100 Dollars (\$1,000,000.00) as “seed” funding to the Good Neighbor Fund described in Section 4.11 above, and the City shall have the discretion to decide the best approach for the initial odor control improvements at or around Kellogg with such seed funding. After the initial investment of the seed funding, CCSD#1 shall conduct an odor control study upon the written request of Milwaukie but no more frequently than once every eighteen (18) months. Such studies shall be paid for by CCSD#1, not be funded by the Good Neighbor Fund, and shall be undertaken within ninety (90) days of receipt of the written request. If the study finds odors that would be reasonably detectable by and objectionable to an ordinary person, then CCSD#1 and City shall jointly investigate additional actions necessary to obviate the odor issues and such expenses shall be paid by CCSD#1 as part of the Wholesale rate.

## **SECTION 5. DEFAULTS AND DISPUTE RESOLUTION**

**5.1 Defaults.** Subject to a Force Majeure Event, extensions of time by mutual consent in writing, or the special circumstances described in Section 5.2, failure or unreasonable delay by any Party to substantially perform any provision of this Agreement, or breach of any term of this Agreement, shall constitute a default (a “General Default”). In the event of an alleged General Default, the Party alleging such a violation shall give the other Party not less than thirty (30) days notice in writing specifying the nature of the alleged General Default and the manner in which the General Default may be cured satisfactorily. During this 30-day period, the Party in charge shall not be considered in default for the purposes of termination or instituting legal proceedings. The defaulting Party must cure such General Default within such 30 day period unless it submits a written notice to the other Party alleging (i) an inability to cure within 30 days and setting forth a plan to expeditiously cure the General Default, or (ii) disputing the General Default notice and requesting dispute resolution as set forth in Section 5.3.

**5.2 Special Defaults.** Except in the case of a Force Majeure Event, failure by City to comply with the relevant provisions of Sections 3 and 4, including but not limited to failure to (i) pay amounts due within the proscribed time period, (ii) disclose new connections or EDU levels, (iii) pay SDC-equivalent charges, (iv) allow non-Domestic Sewage to be delivered to CCSD#1, or (v) allow I/I or peak flow issues beyond the scope

agreed (each, a "Special Default") shall constitute an immediate and material breach of this Agreement. The occurrence of a Special Default shall immediately vest CCSD#1 with the right to either (x) terminate this Agreement with 90 days prior written notice to City without need of any opportunity to cure or other action, step or process, including any set forth in Sections 5.1 and 5.3, or (y) impose a fifteen percent (15%) surcharge on the Rate, SDC charges, interest, and related financial terms until such time as the City comes into compliance with the Agreement.

5.3 Dispute Resolution Steps. Except as otherwise provided in Section 5.2, the Parties agree to attempt to settle any disputes or General Defaults pursuant to the following process:

5.3.1 **Negotiation**. The City Manager of City and the Director of CCSD#1 or other persons designated by each of the disputing Parties will negotiate on behalf of the entities they represent. If the dispute is resolved at this step, there shall be a written determination of such resolution, signed by each the City Manager and the Director, and may be ratified by the governing bodies of the Parties, as appropriate.

5.3.2 **Mediation**. If the dispute cannot be resolved within 30 days of the beginning of negotiation as set forth in Section 5.3.1 or within such longer period of time as may be mutually agreed to by CCSD#1 and City, the Parties shall submit the matter to non-binding mediation. The Parties shall attempt to agree on a single mediator. If the Parties cannot agree on a single mediator, the Parties shall request a list of five (5) mediators from an entity or firm providing mediation services. The Parties will attempt to mutually agree on a mediator from the list provided, but if they cannot agree, each Party shall select one (1) name from such list. The two selected mediators shall select a third person. The dispute shall then be heard by a panel of three (3) mediators, and any common cost of mediation shall be borne equally by the Parties who shall each bear their own costs and fees therefore. If the dispute is resolved at this step, there shall be a written determination of such resolution, signed by each the City Manager and the Director, and ratified by the governing bodies of the Parties which shall be binding upon the Parties.

5.3.3 **Binding Arbitration**. After exhaustion of the preceding processes, any remaining dispute shall be submitted to binding arbitration under the jurisdiction of the Circuit Court of the State of Oregon for Clackamas County pursuant to ORS Chapter 36.

## **SECTION 6. TERM AND TERMINATION**

6.1 Term. This Agreement shall be effective as of July 1, 2012 and shall expire on June 30, 2037.

6.2 Early Termination. This Agreement may be terminated prior to the Termination Date upon (i) the mutual written consent of the Parties, or (ii) upon twenty-four (24) months prior written notice by one Party to the other.

6.2.1 **Early Termination by CCSD#1.** If CCSD#1 exercises its early termination right pursuant to this Section 6.2, the City will be obligated to pay only its pro rata share of CCSD#1 outstanding obligation and debt, including capital debt, that existed at the time the Agreement was entered into and that relates directly to the Kellogg Plant or that was incurred after execution but before notice of termination, that directly relates to the Kellogg Plant. "Pro rata share" means a share consistent with the City's 5-year average of flows based on EDUs prior to the notice of termination.

6.2.2 **Early Termination by City.** If City exercises its early termination right pursuant to this Section 6.2, the City will be obligated to pay for its share of the outstanding debt of CCSD#1 in a manner equivalent to similarly situated parties under ORS 222.524, as though City has been a part of CCSD#1 and was withdrawing.

6.3 Termination of Prior IGAs. The Parties acknowledge and agree that each and all of the Prior IGAs are hereby terminated and shall have no further force or effect.

6.4 Extensions. CCSD#1 and City agree that they shall meet on the first business day of July 2035 to discuss an extension, renewal, or alternative service arrangements for City wastewater, unless terminated earlier pursuant to Section 6.2 hereof.

## **SECTION 7. ADDITIONAL PROVISIONS**

7.1 Other Necessary Acts. Each Party shall execute and deliver to the other all such further instruments and documents as may be reasonably necessary to carry out this Agreement in order to provide and secure to the other Party the full and complete enjoyment of rights and privileges hereunder.

7.2 Severability and Waiver. In case any one or more of the provisions contained in this Agreement shall be invalid, illegal, or unenforceable in any respect, the validity, legality and enforceability of the remaining provisions contained herein shall not be affected or impaired in any way. One or more waivers by either Party of any provision, term, condition or covenant shall not be construed by the other Party as a waiver of subsequent breach of the same by the other Party.

7.3 Amendment. The Agreement may be amended at any time by mutual written agreement.

7.4 Force Majeure. In addition to the specific provisions of this Agreement, performance by any Party shall not be in default where delays or default is due to a Force Majeure Event.

7.5 No Third-Party Beneficiaries. The Parties to this Agreement are the only Parties entitled to enforce its terms. Nothing in this Agreement gives, is intended to give, or shall be construed to give or provide, any benefit or right, whether directly or indirectly or otherwise, to third persons.



7.6 Nonwaiver. Failure by any Party at any time to require performance by any other Party of any of the provisions hereof shall in no way affect such Party's rights hereunder to enforce the same, nor shall any waiver by any Party or parties of the breach hereof be held to be a waiver of any succeeding breach or a waiver of this nonwaiver clause.

7.7 Governing Laws. This Agreement shall be governed and construed in accordance with the laws of the State of Oregon without giving effect to the conflict of law provisions thereof. Venue in connection with any legal proceeding affecting this Agreement shall be in the Circuit Court of the State of Oregon for Clackamas County.

7.8 Number and Gender. Whenever applicable, the use of the singular number shall include the plural, the use of the plural number shall include the singular, and the use of any gender shall be applicable to all genders.

7.9 Successors and Assigns. This Agreement is to be binding on the successors and assigns of the Parties hereto. No assignment of this Agreement shall be effective until the assignee assumes, in writing, the obligations of the assigning Party, and delivers such written assumption to the original Party to this Agreement.

7.10 Notice. Any notice herein required or permitted to be given, shall be given in writing and shall be effective upon receipt for hand delivery or facsimile or upon actual receipt or three (3) days after mailing, whichever is earlier, for notices delivered by U.S. mail, first class postage prepaid, addressed to the Parties as follows:

Clackamas County Service District No. 1  
c/o Water Environment Services  
Attn: Director  
150 Beavercreek Road, 4<sup>th</sup> Floor  
Oregon City, Oregon 97045

City of Milwaukie  
Attn: City Manager  
10722 SE Main Street  
City, Oregon 97222

Changes to the above shall be by notice to the other in the manner provided in this Section 7.10.

7.11 No Waiver. No failure by City or CCSD#1 to insist on the strict performance of any agreement, term, covenant, or condition of this Agreement or to exercise any right or remedy consequent to a breach, and no acceptance of full or partial Rent during the continuance of any such breach, constitutes a waiver of any such breach or of such agreement, term, covenant, or condition. No agreement, term, covenant, or condition to be performed or complied with by either Party, and no breach by either Party, shall be waived, altered, or modified except by a written instrument executed by

the non-breaching Party. No waiver of any breach shall affect or alter this Agreement, but each and every agreement, term, covenant, and condition of this Agreement shall continue in full force and effect with respect to any other then-existing or subsequent breach.

7.12 Cumulative Remedies. Each right and remedy provided for in this Agreement shall be cumulative and shall be in addition to every other right or remedy provided for in this Agreement now or hereafter existing at law or in equity or by statute or otherwise. The exercise or beginning of the exercise by City or CCSD#1 of any one or more of the rights or remedies provided for in this Agreement or now or hereafter existing at law or in equity or by statute or otherwise shall not preclude the simultaneous or later exercise by the Party in question of any or all other rights or remedies provided for in this Agreement or now or hereafter existing at law or in equity or by statute or otherwise.

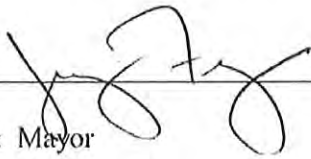
7.13 Annexation. Nothing in this Agreement shall be construed to impair City's ability, if it so desires, to annex into CCSD#1 with due and appropriate process. Similarly, nothing in this Agreement shall obligate City to seek annexation. The Parties agree that upon annexation of City into CCSD#1, if ever, this Agreement shall terminate as of the effective date of the annexation.

*[Signature Page Follows]*

IN WITNESS WHEREOF, the Parties have, pursuant to official action that the respective governing bodies duly authorized the same, caused their respective officers to execute this Agreement on their behalf on the date stated above.

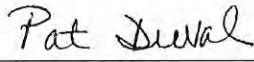
CITY OF MILWAUKIE,  
a municipal corporation

By: \_\_\_\_\_



Title: Mayor

ATTEST: \_\_\_\_\_



Title: City Recorder

CLACKAMAS COUNTY SERVICE  
DISTRICT NO. 1, a county service district

By: \_\_\_\_\_



Title: Chair

ATTEST: \_\_\_\_\_



Title: Secretary

12-6-12  
III . 1.

Exhibit A

Lab Fees & Rates

<b>Lab Fees FY12/13 Per Test</b>	
Ammonia	\$26
BOD	\$32
Conductivity	\$13
E Coli	\$37
Hardness	\$21
Dissolved metals	\$26
Metals	\$21
Nitrate (NO3)	\$28
oPO4	\$30
Phosphorous	\$42
TDS	\$28
TSS	\$24
Winkler DO	\$16
TS/VS	\$26

# Appendix B. Intergovernmental Agreement with City of Portland



Portland

#70

DUPLICATE  
AGREEMENT

EXHIBIT "A"  
Sewer

JCT 10-10-78

THIS AGREEMENT made this 25th day of October, 1978, between the CITY OF PORTLAND, hereinafter referred to as "Portland," and the CITY OF MILWAUKIE, hereinafter referred to as "Milwaukie," both being duly incorporated and established municipal corporations of the State of Oregon.

WITNESSETH

THAT WHEREAS, under authority of their respective charters, Portland and Milwaukie are authorized to enter into agreements for cooperation in the prevention of pollution, and

WHEREAS Portland and Milwaukie each operate and maintain sanitary sewer systems having the capacity and location to provide service to properties of the other; and

WHEREAS certain properties in these areas have a need for sewer services to prevent pollution and to remove health hazards;

NOW THEREFORE, it is mutually covenanted and agreed as follows:

1. Each City agrees to accept for disposal through its facilities, any sewage which originates within the natural drainage limits of its facilities and is within the corporate limits of the other City including areas annexed thereto in accordance with the terms and conditions described herein.
2. (a) Both Portland and Milwaukie shall be responsible for construction of sewage collection facilities and for the enforcement of sewer regulations within their respective boundaries, and will levy and collect fees, service charges and other revenues in accordance with their codes and ordinances. Each City will operate and maintain its own facilities.  
  
 (b) Charges for connection and use of either City's sewer by direct or indirect connection shall be collected by the City wherein the property is located, as though that City owned and operated all the sewerage facilities used. No connection charges, assessments or user charges shall be collected by either City from properties located within the boundaries of the other.
3. Permits and Reporting New Sewer Connections.  
  
 (a) Any property owner desiring service by a direct connection to a sewer of the other City shall make application and pay appropriate fees to both cities for sewer connection permits.  
  
 (b) Industrial and commercial occupancies with process wastes wishing to receive sewerage services must first obtain approval from the City Engineer of the City responsible for treatment of the sewage for both the quality and flow characteristics of sewage to be discharged into the system, and then must obtain a permit from the City maintaining the sewer at the point of connection.  
  
 (c) Each City will report to the other, at the beginning of each quarter, all new sewer connections to the other City's sewer system made during the previous quarter, including the address and number of equivalent dwelling units at each connection.

Equivalent dwelling units shall be evaluated as follows:

<u>Type of Building</u>	<u>Equivalent Dwelling Units</u>
Single Family Residence	1 unit
Multiple Family Dwellings	1 unit per dwelling unit
High Schools	10 students per unit
Elementary Schools	15 students per unit
Motels and Transient Hotels	2 rental spaces per unit
Restaurants	6 seating spaces per unit
Hospitals and Institutions	2 beds per unit
Commercial and Industrial	
Buildings with no process waste	9 employees per unit
Buildings with process waste or high water consumption and occupancies not covered above.	1000 cubic feet of water per month per unit
The minimum evaluation for any connection shall be one unit.	

#### 4. Sewer User Rates and Connection Charges

##### (a) User Rates

The City responsible for treatment of the sewage shall bill the other for such service at the rate charged to similar properties within its City boundaries. No charge shall be made for transportation only.

##### (b) Connection Charges, exclusive of fees for permits and inspections.

Both Portland and Milwaukie shall pay charges for connections to the other City's sewer at rates applicable under the Ordinances of the City providing the service. Such rates shall be those in effect at the time of the connection, applicable to inside the City services.

##### (c) If connections are made to either City's system from properties within the other between July 1, 1973 and the date that this agreement is signed, all terms of the agreement shall apply to such connections as if the agreement were in full force and effect.

##### (d) Public Law 92-500 and Regulations of the U.S. Environmental Protection Agency.

Both Portland and Milwaukie agree to establish such ordinances and codes meeting the conditions for fair and equitable rates applicable to their service areas and for the billing and collection of industrial cost recovery (I.C.R.) charges, all in accordance with the requirements of the U.S. Environmental Protection Agency under Public Law 92-500.

The City in which the industry is located shall collect appropriate I.C.R. charges to be turned over to the City providing the service. Portland and Milwaukie agree to cooperate in the exchange of cost information to be used for the determination and accounting of I.C.R. collections.

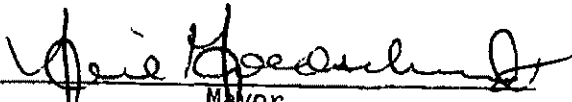
5. Both Portland and Milwaukie agree to comply with and enforce all provisions of the other City's Code and ordinances which pertain to restrictions and limitations on usage of the other City's sewer system.


6. This Agreement shall remain in force for ten years (10 years) from the date first above written. At the end of the above period and each succeeding five-year period, this Agreement shall be automatically self-renewed for an additional five (5 year) period until either party shall have notified the other in writing of his decision not to renew. Notice of non-renewal shall be given five (5) or more years prior to the then effective expiration date. However, this Agreement may be amended or terminated at any time by mutual consent.

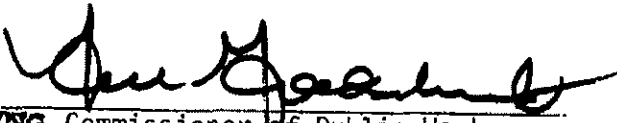
IN WITNESS WHEREOF, the City of Portland, by and through its Mayor and Commissioner of Public Works and the City of Milwaukie, by and through its Mayor and City Manager have caused this instrument to be executed, all on the day and year first above written and in accordance with Ordinance No. **146515**

CITY OF PORTLAND

CITY OF MILWAUKIE

  
\_\_\_\_\_  
Mayor

  
\_\_\_\_\_  
Mayor

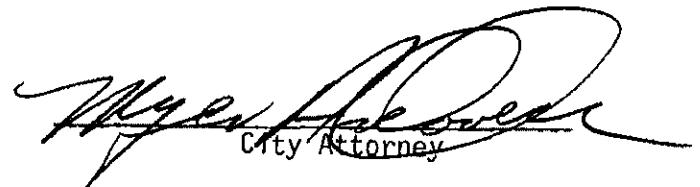
  
\_\_\_\_\_  
ACTING Commissioner of Public Works

  
\_\_\_\_\_  
City Manager

APPROVED AS TO FORM  
APPROVED AS TO FORM

APPROVED AS TO FORM

  
\_\_\_\_\_  
CITY ATTORNEY  
City Attorney

  
\_\_\_\_\_  
City Attorney

ORDINANCE NO. 146515

An Ordinance authorizing the Mayor and the Commissioner of Public Works to execute a reciprocal type sewage agreement with the City of Milwaukie, authorizing the payment of current and back charges, and declaring an emergency.

The City of Portland ordains:

Section 1. The Council finds:

1. Certain areas inside the boundaries of Portland and Milwaukie are situated so that properties of either City can best be served by sewers of the other.
2. Approximately 47 residential or equivalent commercial connections to the Milwaukie sewer system from Portland were authorized by informal agreement and one industrial connection to Portland's system was annexed to Milwaukie prior to the date of this Ordinance.
3. Back charges have accrued against both Cities for prior services in accordance with the sewer rates and charges of the City providing the service and should be paid.
4. In order to carry out the provision of either City's Ordinance and Codes as they pertain to the services described above, a new agreement for sewage disposal is needed.

NOW, THEREFORE, The Council Directs:

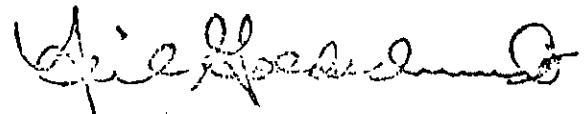
- a. The Mayor and Commissioner of Public Works are authorized and directed to execute an agreement on behalf of the City of Portland with the City of Milwaukie, said agreement to be substantially in accordance with Exhibit "A" attached herewith.
- b. The Mayor and Auditor are hereby authorized to draw and deliver warrants in payment for services performed and to be performed by the City of Milwaukie from time to time in accordance with the provisions of said agreement and upon receipt of billing approved by the City Engineer's staff. Such warrants shall be chargeable to the sewage disposal fund, Bureau of Wastewater Treatment, Milwaukie sewer charges, BUC No. 14900021, Object Code 260.

## ORDINANCE No.

Section 2. The Council declares that an emergency exists, because a delay in completing the agreement with the City of Milwaukie could delay the enforcement of sewer regulations and would delay revenues each City is to collect from the other; therefore, this Ordinance shall be in force and effect from and after its passage by the Council.

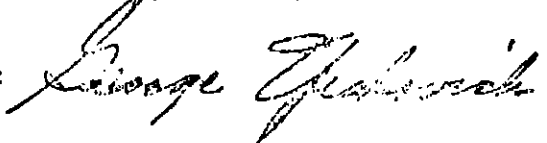
Passed by the Council, SEP 21 1978

Commissioner McCreedy  
R.C. Yonge:jc  
September 21, 1978



Mayor of the City of Portland

Attest:



Auditor of the City of Portland



# ORDINANCE No. 159355

159355

An Ordinance authorizing an amendment to the Sewerage Service Agreement with the City of Milwaukie, and declaring an emergency.

The City of Portland ordains:

Section 1. The Council finds:

1. The cities of Portland and Milwaukie entered into an agreement for exchange of sewerage service in October, 1978. That agreement limits service to properties within the city limits of each party.
2. Milwaukie now wishes to be able to serve properties that are within its urban services boundary, pending annexation of those properties to Milwaukie.
3. The existing Southeast Interceptor has limited capacity at this time, however, upon completion of the SE Relieving Interceptor, there will be adequate capacity for properties within the design area of that sewer.

NOW, THEREFORE, the Council directs:

- a. The Auditor and the Commissioner in Charge are authorized and directed to execute an amendment to the sewerage service agreement on behalf of the City of Portland with the City of Milwaukie, said amendments to be substantially in accordance with Exhibit A attached herewith.

Section 2. The Council declares that an emergency exists, in that a delay in completing the Agreement could delay needed connections to the sewer system and increase the potential for health problems in areas to be served by the City; therefore, this Ordinance shall be in full force and effect from and after its passage by the Council.

Passed by the Council, **JAN 21 1987**

Commissioner Bob Koch  
R. L. Houston:al  
January 6, 1987  
80:rh-ordagreel

**BARBARA CLARK**  
Auditor of the City of Portland

By

*Edna Cervosa* Deputy

Calendar No. **96**

**ORDINANCE No. 159355**

**Title**

An Ordinance authorizing an amendment to the Sewerage Service Agreement with the City of Milwaukee, and declaring an emergency.

THE COMMISSIONERS VOTED AS FOLLOWS:		
	Yeas	Nays
BLUMENAUER	✓	
BOGLE	✓	
KOCH	✓	
LINDBERG	✓	
CLARK	✓	

FOUR-FIFTHS CALENDAR	
BLUMENAUER	
BOGLE	
KOCH	
LINDBERG	
CLARK	

INTRODUCED BY
Commissioner Bob Koch

NOTED BY THE COMMISSIONER
Affairs
Finance and Administration
Safety
Utilities <i>B. R. Koch</i>
Works

BUREAU APPROVAL
Bureau: Environmental Services
Prepared By: R. L. Houston      Date: 01/06/87
Budget Impact Review: <input checked="" type="checkbox"/> Completed <input type="checkbox"/> Not required
Bureau Head: <i>John M. Lutz</i> John M. Lutz

CALENDAR	
Consent	Regular <input checked="" type="checkbox"/>

NOTED BY
City Attorney
City Auditor
City Engineer

Filed JAN 15 1987

**BARBARA CLARK**  
Auditor of the CITY OF PORTLAND

By *Nancy Dunford*  
Deputy

#65  
JAN 12 1996

## INTERGOVERNMENTAL AGREEMENT

SEWER

THIS AGREEMENT, made and entered into by and between the CITY OF PORTLAND, Oregon a municipal corporation (Portland) and the CITY OF MILWAUKIE, a municipal corporation (Milwaukie).

## R E C I T A L S

1. Portland and Milwaukie, under authority of their respective charters, are authorized to enter into agreements for cooperation in the prevention of pollution where each operate and maintain sanitary sewer systems having capacity and location to provide service to properties of the other.
2. Portland and Milwaukie have entered into a reciprocal sewage agreement on 10-25-78 (Portland Agmt. No. 17549, Ord No. 146515) and amended on 3-16-87 (Portland Ord No. 159355) where each city agrees to accept sewage for treatment and disposal by the other and be paid charges for connections at rates applicable under ordinances by the city providing this service.
3. Milwaukie owns and operates a sanitary sewer lift (pump) station at SE Johnson Creek Blvd and SE Brookside Drive located within both the Johnson Creek basin and the natural drainage limits of the Portland 53"x 60" Lents Trunk Sewer Line crossing SE Johnson Creek Blvd about 300 feet from this pump station.
4. Milwaukie Public Works and Portland Environmental Services staffs agree it is desirable and feasible to abandon the Brookside lift station, construct approximately 300 ft of gravity sanitary sewer line in Johnson Cr Blvd from the lift station, and connect to the Lents Trunk Sewer.
5. Portland Environmental Services has given written approval to Milwaukie to connect the Brookside lift station sewer line to the Portland Lents Trunk Sewer under terms of the reciprocal sewage agreement referenced above in Paragraph 2.
6. Milwaukie and Portland agreed it would be cost effective to include construction of this sewer line and removal of the lift station as part of the SE Johnson Cr Blvd Street Improvement Project - Phase I Construction Contract with work scheduled to begin by early March 1996 under management of Portland Transportation Engineering and Development.
7. Milwaukie working closely with Portland is in the final stage of preparing contract plans and specifications for this sanitary sewer work with a total construction cost estimate (including contingencies and construction engineering) of approximately \$100,500 agreed upon by both parties.

NOW, THEREFORE, the parties agree as follows:

- A. Portland agrees to construct the sanitary sewer work described above as part of the SE Johnson Creek Blvd, 32nd to 45th Phase I Construction Contract in accordance with State and local standard construction specifications.
- B. Milwaukie Public Works shall provide Portland Transportation Engineering and Development office with stamped contract plans, specifications of the sanitary sewer work with the total cost estimate of approximately \$100,500 that has been agreed upon by both parties.
- C. Prior to bid advertisement scheduled for early January 1996, Milwaukie shall make an initial payment to Portland as directed by Portland Transportation Engineering and Development in the amount of 65% of the above mentioned total cost estimate for the sanitary sewer work.

D. After bid opening, Milwaukie shall make payment to Portland in the amount of 100% of the accepted bid amount including contingencies and construction engineering as calculated in the original estimate minus the initial 65% payment stipulated in Paragraph C above.

E. After completion of work including punch list items, Milwaukie shall pay Portland any remaining balance including adjustments for change orders and construction engineering due for all work performed.

F. Milwaukie shall assign a staff person to monitor this sanitary sewer work and act as liaison with Portland matters of mutual interest concerning this work.

G. This Agreement becomes effective upon execution of the Agreement by both parties and shall terminate upon completion of the Phase I Construction Contract, if bids are rejected, or if the Contract is terminated with any unused portion of Milwaukie's payment to Portland reimbursed to Milwaukie within 45 days of rejection or termination notice.

H. Milwaukie may terminate this contract after bid opening and prior to bid acceptance if the total bid amount covering the Milwaukie Sanitary Sewer work exceeds 15% of the total cost estimate stipulated in Paragraph B. If Milwaukie terminates under this provision, Milwaukie agrees to pay Portland for any billed contract management costs resulting from Milwaukie's decision, not to exceed 2% of the above mentioned total cost estimate.

I. By mutual agreement, this Agreement may be amended by a written document signed by the authorized representatives of each party.

J. Each party shall be solely responsible for its own activities under this Agreement. Portland and Milwaukie agree to hold harmless, defend and indemnify each other, their officers, agents and employees, against any claims, demands, actions or suits (including attorney fees and costs) brought against them arising out of or relating to each party's responsibilities under this Agreement.

K. Neither party shall assign any part of its rights and duties under this Agreement without the written consent of the other.

L. The parties have caused this Agreement to be executed by their duly appointed officers.

CITY OF PORTLAND

By: *Earl Blumen*  
Commissioner of Public Works

Date: 1/12/96

By: *Barbara Clark*  
Auditor

Approved as to Form:

*Frank Anderson*  
Deputy City Attorney

CITY OF MILWAUKIE

By: *Dan R. Bartlett*

Title: City Manager

Date: 12-18-95

Approved as to Form:

*[Signature]*  
City Counsel

RESOLUTION NO. 51-1995

**A RESOLUTION OF THE CITY COUNCIL OF THE CITY OF MILWAUKIE, OREGON, AUTHORIZING THE CITY MANAGER TO SIGN AN INTERGOVERNMENTAL AGREEMENT BETWEEN THE CITY OF MILWAUKIE AND THE CITY OF PORTLAND.**

**WHEREAS**, Portland and Milwaukie have entered into a reciprocal sewage agreement where each city agrees to accept sewage for treatment and disposal by the other and be paid charges for connections at rates applicable under ordinances by the city providing this service; and

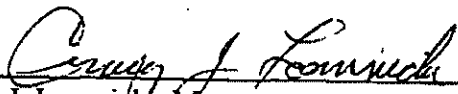
**WHEREAS**, the parties both agree it is desirable and feasible to abandon the Brookside lift station and construct a gravity sewer line to the City of Portland's Lents trunk sewer; and

**WHEREAS**, the City Council would like to continue to cooperatively participate with the City of Portland.


**NOW THEREFORE, BE IT RESOLVED** that the City of Milwaukie authorize the City Manager to sign an Intergovernmental Agreement (IGA) with the City of Portland for the elimination of the Brookside lift (pump) station and construction of approximately 300 feet of sanitary sewer line at SE Brookside Drive and SE Johnson Creek Blvd.

Introduced and adopted by the City Council of the City of Milwaukie, Oregon on

December 5, 1995

  
\_\_\_\_\_  
Craig J. Lomnicki, Mayor

ATTEST:

  
\_\_\_\_\_  
Pat DuVal, City Recorder

APPROVED AS TO FORM:

O'DONNELL, RAMIS, CREW & CORRIGAN

  
\_\_\_\_\_  
City Attorney



# ORDINANCE No. 169681

\* Agreement with City of Milwaukie to provide for a sanitary sewer line in the SE Johnson Creek Boulevard Phase I street construction contract (Ordinance)

The City of Portland ordains:

## Section 1. The Council finds

1. Portland and Milwaukie, under authority of their respective charters, are authorized to enter into agreements for cooperation in the prevention of pollution where each operate and maintain sanitary sewer systems having capacity and location to provide service to properties of the other.
2. Milwaukie Public Works and Portland Environmental Services staffs agree it is desirable and feasible to abandon the Brookside lift (pump) station in Milwaukie and construct approximately 300 ft of gravity sanitary sewer line in SE Johnson Cr Blvd to the Lents Trunk Sewer near SE 45th Ave.
3. This proposed sanitary sewer line is located within the SE Johnson Cr Blvd, 32nd to 45th Aves - Phase I Street Improvement Project with construction scheduled to begin in March 1996 under management of Portland Transportation Engineering and Development.
4. Milwaukie and Portland staffs agree it would be cost effective to include this sanitary sewer work as a part of the SE Johnson Cr Blvd Street Phase I Street Construction Contract.
5. Milwaukie City Council has authorized Milwaukie to enter into an Inter-governmental Agreement with Portland to pay Portland approximately \$100,500 to perform the above sewer work under terms and conditions of that Agreement.

NOW THEREFORE, the Council Directs:

- a. The Commissioner of Public Works and the Auditor are hereby authorized to enter into an agreement similar in form to the agreement attached to the original of this ordinance, and by this reference made a part hereof.

Section 2. The Council declares that an emergency exists because delay in executing this agreement would delay construction and the related environmental and economic benefits to be derived from completion of this sanitary sewer work; therefore, this ordinance shall be in force and effect from and after its passage by the Council.

Passed by the Council, **JAN 03 1996**

Commissioner Earl Blumenauer  
Mulvey Johnson  
December 22, 1995  
(3287.AGMS|COM-IGA-ORD)

**BARBARA CLARK**  
AUDITOR OF THE CITY OF PORTLAND  
BY  
*Barbara Olson*  
DEPUTY

JUL 24 1998

51070

172347

98048

#63

INTERGOVERNMENTAL AGREEMENT

Sewer

THIS AGREEMENT, made and entered into by and between the CITY OF PORTLAND, Oregon a municipal corporation (Portland) and the CITY OF MILWAUKIE, a municipal corporation (Milwaukie).

RECITALS

1. Portland and Milwaukie, under authority of their respective charters, are authorized to enter into agreements for cooperation in the prevention of pollution where each operate and maintain sanitary sewer systems having capacity and location to provide service to properties of the other.
2. Portland and Milwaukie have entered into a reciprocal sewage agreement on 10-25-78 (Portland Agmt. No. 17549, Ord No. 146515) and amended on 3-16-87 (Portland Ord No. 159355) where each city agrees to accept sewage for treatment and disposal by the other and be paid charges for connections at rates applicable under ordinances by the city providing this service.
3. Milwaukie and Portland agreed it would be cost effective to include construction of this sewer line as part of the SE Johnson Creek Blvd. Street Improvement Project - Phase I Construction Contract with work completed in fiscal year 95-96 under management of Portland Transportation Engineering and Development, and the SE 33rd Ave & Sherrett St. Sanitary Sewer Extension Construction Contract with work completed in fiscal year 97-98 under management of Portland Bureau of Environmental Services.
4. Portland, working closely with Milwaukie, determined that Milwaukie's share of the total cost for the SE Johnson Creek Blvd. Street Improvement Project - Phase I Construction Contract is \$29,051.43 and Milwaukie's share of the total cost for the SE 33rd Ave. & Sherrett St. Sanitary Sewer Extension Construction Contract is \$97,092.64 agreed upon by both parties. Therefore, Milwaukie's share of the total cost for both construction Contracts is \$126,144.07.

NOW, THEREFORE, the parties agree as follows:

- A. Portland agrees to construct the sanitary sewer work described above in accordance with State and local standard construction specifications.
- B. After completion of work including punch list items, and after acceptance for the improvements by the City of Milwaukie, Milwaukie shall pay Portland the balance including adjustments for change orders and construction engineering due for all work performed. Milwaukie's share of the total cost for both construction Contracts is \$126,144.07.
- C. This Agreement becomes effective upon execution of the Agreement by both parties.
- D. The City of Milwaukie will be responsible for the maintenance of the sanitary sewer within the Milwaukie city limits. This also includes the 8-inch mainline sewer on SE Sherrett St. from approximately SE 35th Ave. to SE 33rd Ave. (excluding the manhole on SE 33rd Ave.), and any service laterals provided for the City of Milwaukie properties.

E. The City of Portland will be responsible for the maintenance of the sanitary sewer within the Portland city limits. This also includes the 8-inch mainline sewer on SE Sherrett St. from SE 33rd Ave. (including the manhole on SE 33rd Ave.) to SE 30th Ave., and on SE 30th Ave. from SE Sherrett St. to approximately 35-feet to the south (excluding the manhole at the Portland/Milwaukie city limits), and any service laterals along SE Sherrett St. provided for the City of Portland properties.

F. Each party shall be solely responsible for its own activities under this Agreement. Portland and Milwaukie agree to hold harmless, defend and indemnify each other, their officers, agents and employees, against any claims, demands, actions or suits (including attorney fees and costs) brought against them arising out of or relating to each party's responsibilities under this Agreement.

G. The terms of this agreement may be amended by mutual agreement to the parties. Any amendment shall be in writing and refer specifically to this agreement, and shall be executed by the parties.

H. The parties in carrying out the responsibilities under this agreement will comply, and if Portland or Milwaukie contracts with a third party to carry out its responsibility it will ensure that the third party will comply, with all applicable laws including, but not limited to the provisions of ORS Chapter 279.

CITY OF PORTLAND

CITY OF MILWAUKIE

By: [Signature]

Commissioner of Public Works

By: [Signature]

Date: 7/24/98

Title: City Manager

By: [Signature]

Auditor

Date: 7/2/98

Approved as to Form:

Approved as to Form:

[Signature]  
Deputy City Attorney

[Signature]  
City Counsel

172347

ORDINANCE No.

\* Agreement with City of Milwaukie for maintenance and payment of sanitary sewer line installed in the SE Johnson Creek Boulevard Phase I street construction contract and the SE 33rd Ave. & SE Sherrett St. Sanitary Sewer Extension construction contract (Ordinance)

The City of Portland ordains:

Section 1. The Council finds:

1. Portland and Milwaukie, under authority of their respective charters, are authorized to enter into agreements for cooperation in the prevention of pollution where each operate and maintain sanitary sewer systems having capacity and location to provide service to properties of the other.
2. Milwaukie Public Works and Portland Bureau of Environmental Services staffs agree it is desirable and feasible to construct a gravity sanitary sewer line in SE Sherrett St. from SE 30th Ave. to SE 34th Ave., including adjacent properties north and south of SE Sherrett Street.
3. This proposed sanitary sewer line is located within the SE Johnson Cr. Blvd., 32nd to 45th Aves. - Phase I Street Improvement Project and the SE 33rd Ave. & Sherrett St. Sanitary Sewer Extension Project Construction Contracts.
4. Milwaukie City Council has authorized Milwaukie to enter into an Inter-governmental Agreement with Portland to pay Portland \$126,144.07 for the sewer work performed under terms and conditions of that Agreement.
5. The City of Portland will be responsible for the maintenance of the sanitary sewer within the Portland city limits and the City of Milwaukie will be responsible for the maintenance of the sanitary sewer within the Milwaukie city limits under the terms and conditions of the Intergovernmental Agreement.

NOW, THEREFORE, the council directs:

- a. The Commissioner of Public Works and Auditor are authorized to enter into an agreement similar in form to the agreement attached to the original of this ordinance, and by this reference made a part hereof.

Section 2. The Council declares that an emergency exists because a delay in proceeding with this agreement could impact Milwaukie's fund transfer schedule. Therefore, this ordinance shall be in full force and effect from and after its passage by the Council.

Passed by the Council,  
Commissioner Erik Sten JUN 10 1998

Michelle Lostra  
May 27, 1998

BARBARA CLARK  
Auditor of the City of Portland

By *Bette Olson*  
Deputy

# Appendix C. Intergovernmental Agreement with Oak Lodge Water Services



A G R E E M E N T

THIS AGREEMENT made and entered into this 12<sup>th</sup> day of April, 1977, between OAK LODGE SANITARY DISTRICT, a quasi-municipal corporation, by authority of its Board of Directors, hereinafter called the First Party, and the CITY OF MILWAUKIE, OREGON, a municipal corporation, by authority of its City Council, hereinafter called the Second Party, in consideration of the mutual covenants and promises herein contained:

WHEREAS, the First Party operates a sanitary district in the County of Clackamas in an area adjacent to the City of Milwaukie on First Party's northerly boundary from McLoughlin Blvd. west and the City of Milwaukie has installed and provides sanitary services on its southerly boundary adjacent to First Party's boundary, and

WHEREAS, some of the area within each party's boundaries cannot be served by that party due to lack of natural drainage but can be served by the other party, and

WHEREAS, both parties have cooperated with each other to install sanitary facilities in the area previously unserved

by each party, and

WHEREAS, each of the parties are willing to enter into an agreement to mutually provide service for the area described in the maps contained in the offices of both parties, designated "as built maps", and to enter into an agreement for the charges for services to be made one party to the other, and to do all things necessary to carry out the intent of this agreement, it is

HEREBY AGREED BETWEEN THE PARTIES as follows:

1. That the property which is the subject of this agreement is designated on map identified as Maps No. 41, 60 and 61 in the office of the First Party, and on a map designated as 5-131, 8-131 and 9-131 in the office of the Second Party.

2. Each party will issue permits and inspect connections of all properties connected to the collection system within its own district irrespective of which party serves the property to be connected. Neither party will charge the other party a connection charge for any property connected which it serves. Neither party shall charge the other any surcharge during the term of this agreement.

3. First Party will furnish Second Party, bimonthly, a list of the total number of units connected into their lines

which shall be served by Second Party. Second Party will bill First Party at the prevailing rate per unit per month, for each unit connected. Each party will bill their own property owners for the monthly billing at the rate prevailing in that party's district.

This agreement supersedes that certain agreement dated August 2, 1967, between First Party and Second Party, relative to service of an apartment house in First Party's district containing 50 units, which apartment house shall be serviced by First Party and First Party shall bill Second Party for the service to said apartment house and any other units that it may serve at the prevailing rate.

Should there be a change in the monthly charge to be charged by either party, then the party changing the monthly charge shall so notify the other party.

4. The monthly service charge to be paid to either district shall be paid continuously from the date of final inspection.

It shall be the responsibility of each of the parties to this agreement to collect any delinquent accounts on any property it serves within its jurisdiction.

5. Each party shall notify the other, in writing, of any

pending application for connection to the collection system which shall affect the other party.

6. All laws, rules, regulations and ordinances of both parties shall apply to this agreement and shall be obeyed by both parties to this agreement, including those users and parties receiving benefits under this agreement, whether they be third party beneficiaries or not. It shall be the duty of both parties to see that said laws, rules, regulations and ordinances are complied with by the users contemplated by this agreement. Each party shall have the authority to enforce the terms of the Waste Discharge Permit issued by the State of Oregon or the federal government.

7. This agreement shall not be subject to termination unless notification is in writing and served upon the other party at its office, six months prior to the proposed termination date.

8. This agreement and the terms thereof shall be subject to review by either or both parties at the expiration of five years from the date of signing hereof, and renewal of this agreement may be accomplished by a letter, in writing, to that effect, stating the terms of the renewal and any changes in said agreement, and signed by both parties.


9. No sanitary service by either party to any other property other than heretofore described is contemplated by the terms of this agreement.

DATED this 6<sup>th</sup> day of June, 1977.

OAK LODGE SANITARY DISTRICT

CITY OF MILWAUKIE


  
President

  
Mayor

ATTESTED:

ATTESTED:



  
Recorder

"FIRST PARTY"

"SECOND PARTY"



Oak Lodge Sanitary District and City of Milwaukie  
Memorandum of Understanding – Wastewater Treatment Capacity

97926

**MEMORANDUM OF UNDERSTANDING  
FOR PLANNING LEVEL ANALYSIS OF WASTEWATER TREATMENT  
CAPACITY EXPANSION COST AT THE OAK LODGE SANITARY DISTRICT  
WASTEWATER TREATMENT PLANT  
BY AND BETWEEN  
OAK LODGE SANITARY DISTRICT  
AND  
THE CITY OF MILWAUKIE**

**RECITALS**

Whereas, Oak Lodge Sanitary District desires to provide wastewater treatment services to District residents in the most efficient manner possible; and

Whereas, the limitations imposed by a restrictive service area boundary may prevent maximizing potentially available economies of scale; and

Whereas, Oak Lodge Sanitary District desires to evaluate the potential efficiencies that may be achievable through various partnerships with other adjacent municipalities; and

Whereas, Oak Lodge Sanitary District has available some additional land not currently being utilized for wastewater treatment processes; and

Whereas, Oak Lodge Sanitary District is preparing to develop new and replacement facilities whose configuration is critical to the ultimate developable capacity of the existing site and adjoining land; and

Whereas, the City of Milwaukie has its wastewater treated at the Kellogg Creek Water Pollution Control Plant owned by Clackamas County Service District No. 1 and operated by Clackamas County Department of Utilities; and

Whereas, the Kellogg Creek Water Pollution Control Plant is at or nearing capacity requiring additional capacity to be planned either at the current site or in another location; and

Whereas, the City of Milwaukie desires to facilitate long term planning and development of its valuable waterfront area; and

Whereas, expansion of the Kellogg Creek Water Pollution Control Plant at its current location may not be consistent with the long term future vision of waterfront development; and

Whereas, the City of Milwaukie desires to explore all reasonable options for addressing its current and future wastewater treatment needs in the interest of its citizens;

Oak Lodge Sanitary District and City of Milwaukie  
Memorandum of Understanding – Wastewater Treatment Capacity

**AGREEMENT**

Oak Lodge Sanitary District and the City of Milwaukie jointly agree to undertake a planning level study designed to ascertain order of magnitude costs for expansion of the existing Oak Lodge Sanitary District Wastewater Treatment Plant and all necessary facilities to accommodate the transportation and treatment of wastewater from the City of Milwaukie.

This joint study shall be conducted by Black & Veatch and substantially conform to the draft letter agreement attached hereto and incorporated herein.

The cost of this joint study shall not exceed ten thousand dollars (\$10,000) and shall be borne equally by Oak Lodge Sanitary District and the City of Milwaukie. Oak Lodge Sanitary District agrees to invoice the City of Milwaukie, and the City agrees to promptly pay such invoices, for all proportional costs associated with the joint study.

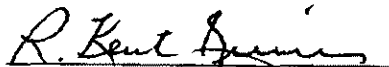
Oak Lodge Sanitary District agrees to manage the study, provide progress reports, invoice progress payments, and coordinate meetings with the consultant.


The joint study shall commence no later than September 1, 1997 and shall be completed no later than December 1, 1997.

Each party to this Memorandum of Understanding warrants that they are duly authorized to execute this agreement on behalf of their respective jurisdiction.

OAK LODGE SANITARY DISTRICT

CITY OF MILWAUKIE

  
R. Kent Squires,  
General Manager

  
Dan Bartlett,  
City Manager

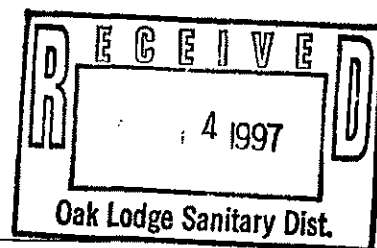
8.14.97  
Date

8/13/97  
Date



**BLACK & VEATCH**<sub>LLP</sub>

Suite 200, 4004 Kruse Way Place, Lake Oswego, Oregon 97035 (503) 699-7556



Oak Lodge Sanitary District

August 13, 1997

Mr. R. Kent Squires  
General Manager  
Oak Lodge Sanitary District  
14611 SE River Rd  
Milwaukie, OR 97267-1198

**Subject: Letter Proposal to Perform Analysis  
and Technical Memorandum Regarding  
Transfer of Waste Flow from Kellogg  
Creek Facility to Expanded Oak Lodge  
Facility**

Dear Mr. Squires:

In response to your request, this letter will serve as our proposal to perform an analysis and produce a Technical Memorandum regarding a phased approach for transferring all or a portion of the wastewater flow from the Kellogg Creek Waste Treatment Facility to an expanded Oak Lodge Waste Treatment Facility. Our proposal response is divided into the following four sections:

- Background
- Scope of Services
- Estimated Level of Effort and Compensation Budget
- Schedule

### **Background**

The Oak Lodge Sanitation District (OLSD) in response to previous study work and recent inquiries from the City of Milwaukie, is requesting a proposal from Black & Veatch to conduct an analysis and prepare a Technical Memorandum outlining the facilities and order-of-magnitude costs for diverting untreated waste flows from the Kellogg Creek Waste Treatment Facility to an expanded Oak Lodge Waste Treatment Facility. This basic alternative was considered in the KOLTT Subregional Wastewater Treatment Options Study (KOLTT Study) completed in 1995 and was one of the final options developed. The work proposed would in general follow the same level of analysis and facility layout and cost detail as performed in the KOLTT Study. Black & Veatch was

part of the consultant team that performed the KOLTT Study with the responsibility for the technical engineering evaluations.

### **Scope of Services**

1. Gather existing data from OLSD and the City of Milwaukie including, but not limited to, existing facilities' size, NPDES permit requirements, flow projections, copies of current facility or master plans, and other related reports that have been developed since the KOLTT Study. It is noted that Black & Veatch has some of this referenced data in its possession.
2. Meet with representatives of the OLSD and the City of Milwaukie to discuss work scope, confirmation of data and assumptions and work product.
3. Technical analysis will consider the following conditions and assumptions:
  - a. Develop facilities that allow diversion of flows at 5 mgd increments over an established time period.
  - b. Treatment facilities and corresponding capital and operation costs to be developed for two effluent discharge permit levels including:
    - 10/10 Limit (Refers to effluent BOD<sub>5</sub> equal to or less than 10 mg/L and effluent suspended solids equal to or less than 10 mg/L.
    - 20/20 Limit (same as above only substitute 20 in place of 10).
  - c. Facility improvements to include: pumping improvements, transmission sewers/force mains and treatment improvements at expanded Oak Lodge Wastewater Treatment site.
  - d. It is assumed that additional land in the immediate vicinity of the Oak Lodge Wastewater Treatment Plant site will be acquired to accommodate the new treatment facilities.
  - e. Treatment facilities will be developed at various cost sensitivity levels varying from more conventional, above ground improvements to basically hidden or buried improvements allowing potential partnering of the site development with the Park District.





Hourly Rate	\$119	\$110	\$92	\$45	\$35						
1. Gather Data	2		8					10	\$974	\$30	\$1,004
2. Initial Meeting	3		4		1			8	\$760	\$25	\$785
3. Technical Analysis	2	2	30					34	\$3,218	\$200	\$3,418
4. Draft Technical Memo	2	2	6	8	6			24	\$1,580	\$200	\$1,780
5. Review and Finalize Technical Memo	3	2	8	2	2			17	\$1,473	\$150	\$1,623
Total Hours	12	6	56	10	9			93	--	--	--
Total Costs	\$1,428	\$660	\$5,152	\$450	\$315			--	\$8,005	\$615	\$8,610

It is suggested the budgeted compensation limit be \$9,000.

Mr. R. Kent Squires

Page 5  
August 13, 1997

**Schedule**

- Kickoff Meeting with OLSD and other involved entities 2 Weeks after receipt of data
- Submit Draft Technical Memorandum 3 Weeks following Kickoff Meeting
- Deliver Final Technical Memorandum 2 Weeks following meeting to receive review comments.

Please call if you have any questions or require revisions to this proposal. We appreciate the opportunity to submit this proposal and look forward to performing the services.

Very truly yours,

BLACK & VEATCH LLP



Randall J. Krueger, P.E.  
Partner

rls  
n:\prop218\83218\oaklodge\squires.wp5



# OAK LODGE SANITARY DISTRICT

*Protecting our valuable water resources*

August 14, 1997

Mr. Dan Bartlett, City Manager  
City of Milwaukie  
10722 SE Main Street  
Milwaukie, Oregon 97222

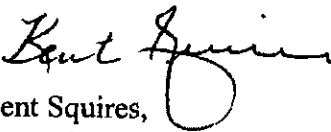
Dear Dan:

Enclosed is a Memorandum of Understanding regarding the proposed "Planning Level Analysis of Wastewater Treatment Capacity Expansion Cost at the Oak Lodge Sanitary District Wastewater Treatment Plant". Attached to the Memorandum of Understanding is the revised proposal to perform analysis and provide technical memoranda regarding the transfer of waste flow from Kellogg Creek/City of Milwaukie to an expanded Oak Lodge facility. As described in the Memorandum of Understanding the joint study shall not exceed \$10,000 and that cost shall be borne equally by Oak Lodge Sanitary District and the City of Milwaukie.

Please execute both originals of the Memorandum of Understanding and return one (1) signed copy to this office. If you have any questions or desire additional information please feel free to give me a call at 653-1653.

Sincerely,

OAK LODGE SANITARY DISTRICT

  
Kent Squires,  
General Manager

RKS/kld



**INTERGOVERNMENTAL AGREEMENT**

This agreement is made and entered into this 27<sup>th</sup> day of July, 2000 by and between Oak Lodge Sanitary District (hereinafter "District"), a municipal corporation of the State of Oregon, and the City of Milwaukie (hereinafter "City"), a municipal corporation of the State of Oregon.

**RECITALS:**

1. Oak Lodge Sanitary District is a sanitary district, organized and existing under the laws of the State of Oregon. The City of Milwaukie is an Oregon municipal corporation, organized and existing under its municipal charter, ordinances and the laws of the State of Oregon.
2. Oregon Revised Statutes, Chapter 190, authorizes units of local government to enter into intergovernmental agreements for the performance of their duties or for the exercise of powers conferred upon them.
3. Oak Lodge Sanitary District owns, operates, and maintains a variety of equipment necessary in the performance of its functions. This equipment, while necessary to meet the public service needs of the District's residents, businesses, and industries, is not always utilized in a manner which capitalizes on the equipment investment to the extent practicably attainable.
4. City of Milwaukie owns, operates, and maintains a variety of equipment necessary in the performance of its functions. This equipment, while necessary to meet the public service needs of the City's residents, businesses, and industries, is not always utilized in a manner which capitalizes on the equipment investment to the extent practicably attainable.
5. Oak Lodge Sanitary District has a well equipped and trained workforce that performs a variety functions related to the services the District delivers.
6. The City of Milwaukie has a well equipped and trained workforce that performs a variety functions related to the services the City delivers.
7. Oak Lodge Sanitary District and the City of Milwaukie agree that the public interest may best be served by sharing equipment between jurisdictions to avoid unnecessary duplication of investment of public funds in equipment which may be underutilized. Oak Lodge Sanitary District and the City of Milwaukie also agree that the public interest may best be served by sharing a well equipped and trained workforce when situations arise that require additional personnel, specific expertise or knowledge, and/or emergency action, to avoid unnecessary duplication of staff, equipment, and/or training.
8. Oak Lodge Sanitary District and the City of Milwaukie agree that sharing resources, as described above, between jurisdictions will promote efficiency and effectiveness in local government administration and service delivery.

NOW, THEREFORE, the premises being in general as stated in the foregoing recitals, it is agreed by and between the parties hereto as follows:

1. **EQUIPMENT SHARING.** District and City agree to make available to each other equipment as listed in the attached Exhibit A, and any amendments or revisions thereto. District and City agree to make available to each other only equipment which is in a well maintained and fully operable condition.

2. **SCHEDULED EQUIPMENT.** District and City agree to make available to each other equipment as listed on the attached Exhibit A provided reasonable notice is given and such request does not compromise District's or City's ability to meet its own needs and obligations. Where equipment use by either party to this agreement is anticipated on a regular or recurring basis, the requesting party shall endeavor to develop a schedule which shall be agreeable to both parties and which shall, to the extent practicable, provide assurances that such equipment will be available at the time requested. The parties to this agreement understand and agree that effective utilization of work crews is paramount to efficient and effective service delivery. Therefore, if circumstances require the cancellation of scheduled equipment use, the party canceling availability shall provide reasonable notice to the other. Reasonable notice shall be defined as a minimum of 48 hours prior to the scheduled equipment availability unless an emergency exists which precludes such notice. In cases of emergency, notice shall be given at the earliest possible time.

3. **UNSCHEDULED EQUIPMENT.** District and City agree to make available to each other equipment as listed on the attached Exhibit A provided reasonable notice is given and such request does not compromise District's or City's ability to meet its own needs and obligations. Where equipment use by either party to this agreement is desired on an "as needed" basis, the requesting party shall endeavor to provide as much advance notice as is reasonably practical given the nature of the parties' work and the need for effective crew scheduling. Such notice shall not be made less than 24 hours prior to the desired time of availability and shall include the desired duration of use.

4. **BORROWER RESPONSIBILITIES.** The user (District or City) of the equipment owned and maintained by the other shall be responsible for its care and security during the time of possession. The owner (District or City) of the equipment shall endeavor to provide equipment which is well maintained and operable in all respects. The user (District or City) of said equipment, through acceptance by authorized personnel, shall acknowledge the condition and fitness for purpose, and shall use the equipment only for its intended purpose. User (District or City) shall be responsible for returning equipment to Owner (District or City) in the condition received. Fuel, oil, and other routinely consumable supplies (water, special filters, etc.) shall be the responsibility of the user of the equipment to the extent such consumables are regularly and routinely consumed in the performance of the equipment's purpose. Maintenance activities for which there are normally scheduled maintenance intervals such as routine engine oil and filter changes, chassis lubrication, etc., shall remain the responsibility of the owner except where the borrower's use exceeds those routine maintenance intervals. In such cases the user shall be responsible for these regularly scheduled maintenance activities.



5. **INSURANCE.** Each party to this agreement shall maintain at all times levels of appropriate insurance coverage, including liability coverage, to insure against any loss incurred in the use of owners equipment, at an amount that would cover any and all losses including the use of rental replacement equipment during the period of time the owners equipment is being repaired or replaced.

6. **DAMAGE.** Whenever equipment subject to this agreement is damaged, or worn to a point requiring repair, and when such damage or wear exceeds routine wear and tear, the borrower shall be obligated to repair or replace said equipment. Any repairs to an owner's equipment shall be made in a manner that returns the damaged equipment to the condition existing at the time borrower accepted the equipment. Any replacement of the Owner's equipment shall result in replacement with equipment equal to or better than the original. In all such cases Owner shall have the right to determine original equipment capability including quality and performance and shall reserve the right to test proposed replacement in accordance with the plans, specifications, performance requirements, and general equipment quality as if the owner was conducting the purchase.

7. **LABOR SHARING.** District and City agree there may be times, both of an emergency and non-emergency nature, where the sharing of labor may be in the public interest. Any sharing of labor between jurisdictions shall be governed by the terms and conditions herein.

(a) **Request For Assistance.** Each party hereto agrees that any and all requests for assistance shall be made by the Chief Executive Officer (CEO) or Chief Administrative Officer (CAO), or designee, to the other party's CEO/CAO, or designee. Where emergency conditions exist, such requests may be made verbally and followed up with a brief written explanation of the nature of the emergency. Where assistance is requested which is of a non-emergency nature, the requesting party (hereinafter Requester) shall provide a written explanation of the reason for the request, expected duration of required assistance, and equipment, materials, and specialized nature of personnel required to efficiently and effectively perform the work.

The nature of this agreement implies emergency requests for assistance shall be acted upon with the primary concern being maintenance or restoration of services essential for public safety, health, and welfare.

(b) **Response.** Each party hereto agrees to make available to the other party, as soon as is reasonably practicable following request for assistance in paragraph 7(a) above, such equipment, materials, and personnel as the responding party (hereinafter Respondent) has reasonably available, until such time as the Requester has the use of its regular workforce in sufficient quantity to provide service.

Nothing contained herein shall be construed in a manner as to permit the Requester to maintain a workforce, equipment, materials, or practice which is inadequate to regularly and routinely perform the work normally required except as may be contemplated in a separate Intergovernmental Agreement, separate

attachment hereto, or other legal arrangement for the provision of permanent services by either party to this agreement to the other.

(c) **Release of Respondent.** As soon as the services of the Respondent, its equipment, materials, or personnel are determined to be no longer required by the Requester, the Requester shall release the Respondent.

Nothing contained herein shall be construed as preventing the Respondent from recalling its equipment, materials, or personnel should conditions within the Respondent's jurisdiction warrant such a recall. In the event of a recall of Respondent's equipment, material, or personnel, Respondent shall make every reasonable attempt to provide the assisted party with notice which is calculated to be reasonably practicable under the circumstances. The parties hereto agree that under no circumstances will such a recall place either party's personnel in a position of imminent danger to safety, health, or life. Respondent agrees in such circumstances to remain until personnel are removed from danger and the worksite has been temporarily secured.

## 8. EXPENSES

### (a) **Expenses During Planned Events.**

- (i) All expenses incurred by the Respondent during planned or anticipated events, including but not limited to direct expense, indirect expense, loss, and overhead in the performance of the functions and activities within the Requester's jurisdiction and at the Requester's direction, shall be borne by the Requester.
- (ii) Where charges for services rendered are deemed appropriate by the Respondent, an itemization of such expense shall be provided by the Respondent in accordance with Respondent's normal practice of cost allocation for equipment, material, and labor.
- (iii) The parties hereto agree that the chargeable rates for labor, materials and supplies, and equipment usage, which are the party's current rates and are not included in the attachments hereto, shall be provided to the Requester by Respondent within a reasonable time at the request of the other party.
- (iv) Responsibility for payment of wages, benefits, taxes, and other employment related expense incurred by the Respondent in assisting the Requester shall not be transferred to the Requester but will remain with the Respondent. Reimbursement for such expense shall be accomplished in accordance with the terms and conditions outlined in (d)(i), (ii), and (iii) above.

(b) **Expenses During Emergency Events.**

- (i) Expenses incurred by the Respondent in assisting the Requester during emergency or disaster situations, including but not limited to direct expense, indirect expense, loss, and overhead in the performance of the functions and activities within the Requester's jurisdiction and at the Requester's direction, shall not be charged to the Requester. Such expense shall be considered in the interest of the general public welfare and in the spirit of public service.
- (ii) Responsibility for payment of wages, benefits, taxes, and other employment related expense incurred by the Respondent in assisting the Requester shall not be transferred to the Requester but will remain with the Respondent for the reasons denoted in 8.(b)(i) above.

9. **MATERIALS, SUPPLIES, AND PURCHASE AGREEMENTS.** During the life of this agreement and subject to the terms of any applicable purchase agreements, each party agrees to make available to the other such materials, supplies, and purchase agreements as may be desirable to the other. All such materials, supplies, and/or purchase agreements shall be governed by the following conditions:

- (a) Materials and supplies may be made available upon request, at reasonable cost, subject to the provider's own needs and minimum stock requirements. Where the parties to this agreement find there to be an advantage to quantity purchases to meet both of their needs on a regular or recurring basis, the parties shall develop a separate attachment to this agreement defining the expected quantity and frequency of need, allocating responsibility for bidding, purchasing, or otherwise procuring at competitive cost, and assigning responsibility for purchase, storage, inventory control, and invoicing.
- (b) The parties hereto may enter into separate or joint procurement contracts for the acquisition of equipment, materials, or services. Each contract of one of the parties shall be made available to the other subject to any legal restrictions or contractual terms and conditions. The parties hereto may elect to jointly develop annual procurement contracts for goods or services of an infrequent or non-recurring basis. Such joint procurement contracts shall be so identified and shall be attached to this agreement defining the expected quantity, allocating responsibility for bidding, purchasing, or otherwise procuring at competitive cost, and assigning responsibility for purchase, delivery, storage, and invoicing.

**10. INVENTORY INFORMATION.** Each party hereto agrees to develop and provide to the other an inventory of equipment, materials, and supplies which may be made available to the other in the context of this agreement. Said inventory information may include available spare parts and specialized tools used in the maintenance and repair of equipment contemplated for use under this agreement. The parties hereto agree to develop inventory information within six (6) months of the date of execution of this agreement and to incorporate said inventories as appropriately designated exhibits to this agreement.

**11. FACILITY INFORMATION.** Each party hereto agrees to provide to the other upon request maps, manuals, operational procedures, and other materials as may be appropriate to enable efficient and effective rendering of service or assistance.

**12. COSTS AND INVOICING (including interest for delinquencies).** Each party to this agreement agrees to charge the rates or costs as specified in the attachments as may be amended from time to time to reflect actual market value or the true cost of ownership including all regular maintenance activities, true cost of labor, or true cost of acquisition. Charges may include the total cost of provision or procurement including, but not limited to, labor and overhead, shipping, delivery, storage, and inventory control, and accounting and invoicing. Charges shall be invoiced monthly by the entity providing goods or services for all activities occurring during the previous month. Payment of all invoices shall occur within thirty (30) days of receipt and shall be addressed as specified on the invoice. Invoices not paid within thirty (30) days shall be subject to interest, which shall accrue at the rate of one percent (1%) per month on the unpaid balance.

**13. NOTICE.** Any notice under this agreement, except in emergency, shall be in writing and shall be effective when actually delivered or when deposited in the mail, registered or certified, addressed to the parties at such addresses as either party may designate by written notice to each other. Emergency notice may be by telephone or in person and shall be confirmed in writing and delivered in the same manner as herein above within five (5) days. Notice shall be given to the following:

General Manager  
Oak Lodge Sanitary District  
14611 SE River Road  
Milwaukie, Oregon 97267

City Manager  
City of Milwaukie  
10722 SE Main Street  
Milwaukie, Oregon 97022

**14. RENEWAL.** This agreement and the terms thereof shall be subject to review, renewal, or renegotiation by both parties at the expiration of one (1) year from the date of signing hereof, or at any other time deemed appropriate by both parties. This agreement may be automatically renewed for a successive one (1) year term, unless either of the parties requests review or renegotiation of its terms no later than ninety (90) days prior to

the end of the current term. Subsequent renewals of this agreement shall be accomplished by a letter, in writing, to that effect, stating the terms of the renewal and any changes in said agreement, and signed by the CEO of both parties.

**15. TERMINATION.** This agreement is conditioned upon the faithful performance by both parties of all the terms and provisions hereof which on its part are to be kept and performed. Either party may terminate this agreement on account of breach of its terms by the other party, upon thirty (30) days written notice.

**16. AUDIT.** Each party agrees that the other may at any reasonable time upon reasonable notice inspect the books and records of the other with respect to matters within the purview of this agreement for the purpose of determining the accuracy of any expense accounting submitted.

**17. INDEMNIFICATION AND LIABILITY INSURANCE.** Each party agrees to hold the other harmless from any liability arising out of any accident or injury to any goods or persons whatsoever arising out of any act or omission of the other occurring in connection with the carrying out of the agreements and activities contained herein. Each party agrees to obtain such insurance as is necessary to cover the liabilities herein agreed to be indemnified for the risks and limits set forth in Chapter 30, Oregon Revised Statutes, and as they may be amended from time to time during the term of this agreement.

**18. AMENDMENTS.** The terms of this agreement may be amended by mutual agreement of the parties. Any amendments shall be in writing and shall refer specifically to this agreement, and shall be valid only when executed by the CEO of both parties to this agreement and attached hereto.

**19. PREVAILING PARTY.** In any action brought by either party to enforce the terms of this agreement, the prevailing party shall be entitled to recover all costs including reasonable attorney's fees as may be determined by the court having jurisdiction, including any appeal therefrom.

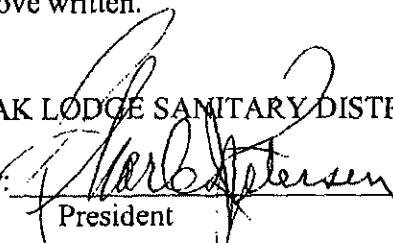
**20. SEVERABILITY.** The invalidity of any section, clause, sentence or provision of this agreement shall not affect the validity of any other part of this agreement which can be given effect without such invalid part or parts.

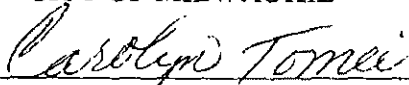


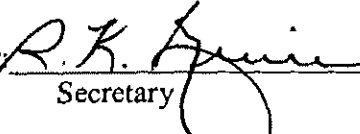
IN WITNESS WHEREOF, the parties have set their hands as of the date and year herein above written.


OAK LODGE SANITARY DISTRICT

CITY OF MILWAUKIE

By:   
President

By:   
Mayor

By:   
Secretary

By:   
Recorder

**Attachment A**  
**To**  
**Intergovernmental Agreement**  
**Between**  
**Oak Lodge Sanitary District**  
**And**  
**City of Milwaukie**

<u>Equipment</u>	<u>Rate/Hr.</u>
Tankers (3500 gallon)	\$25.00 <sup>1</sup>
Dump Truck (5 Yard)	\$15.00 <sup>1</sup>
Backhoe (JCB 1400B w/trailer)	\$25.00 <sup>1, 2</sup>
Hydrocleaner	\$18.00 <sup>1, 3</sup>
Vac-Con (Hydrocleaner/Vacuum Truck)	\$65.00 <sup>1, 4</sup>
Sewer Line TV/Grouting Equipment	\$45.00
Small Diameter TV Camera (lateral)	\$20.00
Pavement Cutter	\$12.00 <sup>1</sup> plus \$3.00/.001" wear
Shoring Trailer, Shores, and Trench Shield	\$15.00

<sup>1</sup> Consumables, such as fuel and oil, which are regularly consumed in the usage of this equipment shall be replaced. Where such consumables are not replaced, they shall be billed at cost.

<sup>2</sup> Hours of usage will be billed based upon Operating Hour Meter.

<sup>3</sup> Hours of usage will be based on Hose Reel Hour Meter.

<sup>4</sup> Hours of usage will be based on the combined readings of the Auxiliary and Fan Hour Meters.

**Attachment B  
To  
Intergovernmental Agreement  
Between  
Oak Lodge Sanitary District  
And  
City of Milwaukie**

<b>Class of Worker</b>	<b>Hourly Rate</b>
Line Maintenance Technician <sup>1</sup>	\$50.04
Wastewater Treatment Plant Operator <sup>2</sup>	\$52.36
Backhoe Operator	\$54.13
Laboratory Technician	\$54.54
Maintenance Mechanic	\$48.97
Buildings/Grounds Maintenance	\$46.14
Clerical	\$43.18
Senior Civil Engineer <sup>3</sup>	\$73.25
Inspector <sup>4</sup>	\$52.75
Truck Driver <sup>5</sup>	\$51.98
Public Relations/Public Information <sup>6</sup>	\$54.71

<sup>1</sup>Skilled in all facets of operation and maintenance of Sanitary Sewer and Surface Water Management systems. Certified by DEQ in Waste Water Collection System operation and maintenance up through Class IV.

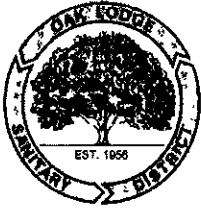
<sup>2</sup>Certified by DEQ in Waste Water Treatment Plant Operation up through Class IV.

<sup>3</sup>Registered Professional Engineer in Oregon and Idaho.

<sup>4</sup>Includes Erosion Control Inspection, Surface Water Management Facility Inspection, Building Sewer Inspection (Certified), Backflow Prevention Device Inspection and Testing (Certified).

<sup>5</sup>Licensed to operate Trucks of all sizes up through Class 8 (Class A CDL).

<sup>6</sup>Skilled in the development and production of Newsletters, Brochures, Displays, and other Public Information/Education mediums. Skilled in elementary classroom education through presentation of River Rangers<sup>®</sup> program.



# OAK LODGE SANITARY DISTRICT

*Protecting our valuable water resources*

August 2, 2000

Records and Information Management Department  
Attn: Barb Kwapich  
10722 SE Main Street  
Milwaukie, OR 97222

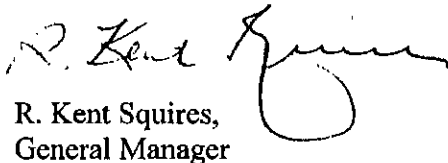
Dear Ms. Kwapich:

Enclosed please find a fully executed copy of the IGA between the City of Milwaukie and Oak Lodge Sanitary District. We look forward to sharing resources with the City of Milwaukie that will promote efficiency and effectiveness in our service delivery and added value for the public.

If you have any questions about the document, feel free to call me at 503-653-1653.

Sincerely,

OAK LODGE SANITARY DISTRICT



R. Kent Squires,  
General Manager

RKS/kdr

F:\admin\corresp\kent2000\IGACOMKwapichcoverltr.doc



# Appendix D. Buildable Lands Inventory Technical Memorandum



---

MEMORANDUM

## Methodology and Initial Results (DRAFT) City of Milwaukie Infrastructure Scenarios

DATE September 24, 2019  
TO David Levitan and Denny Egner, City of Milwaukie  
FROM Andrew Parish and Matt Hastie, APG  
CC

---

### INTRODUCTION

---

The City of Milwaukie is currently undertaking infrastructure planning that will look at the implications of long-term growth under various land use scenarios. This memorandum describes the methodology and initial results of updated residential capacity calculations for infrastructure scenario planning. The methodology described below updates and revisits the key assumptions from APG's 2016 Buildable Lands Inventory (BLI) work completed for the City of Milwaukie.

### METHODOLOGY OF ANALYSIS

---

#### Key Steps and Assumptions from 2016 Buildable Lands Inventory (BLI)

- **Step 1** of the 2016 BLI updated the data available through Metro and other sources to better reflect development activity and recent ordinances adopted by the City of Milwaukie. It also evaluated environmental constraints, including floodplains, steep slopes, Title 3 areas, and Title 13 areas and determined the developable acreage for each taxlot within the city.

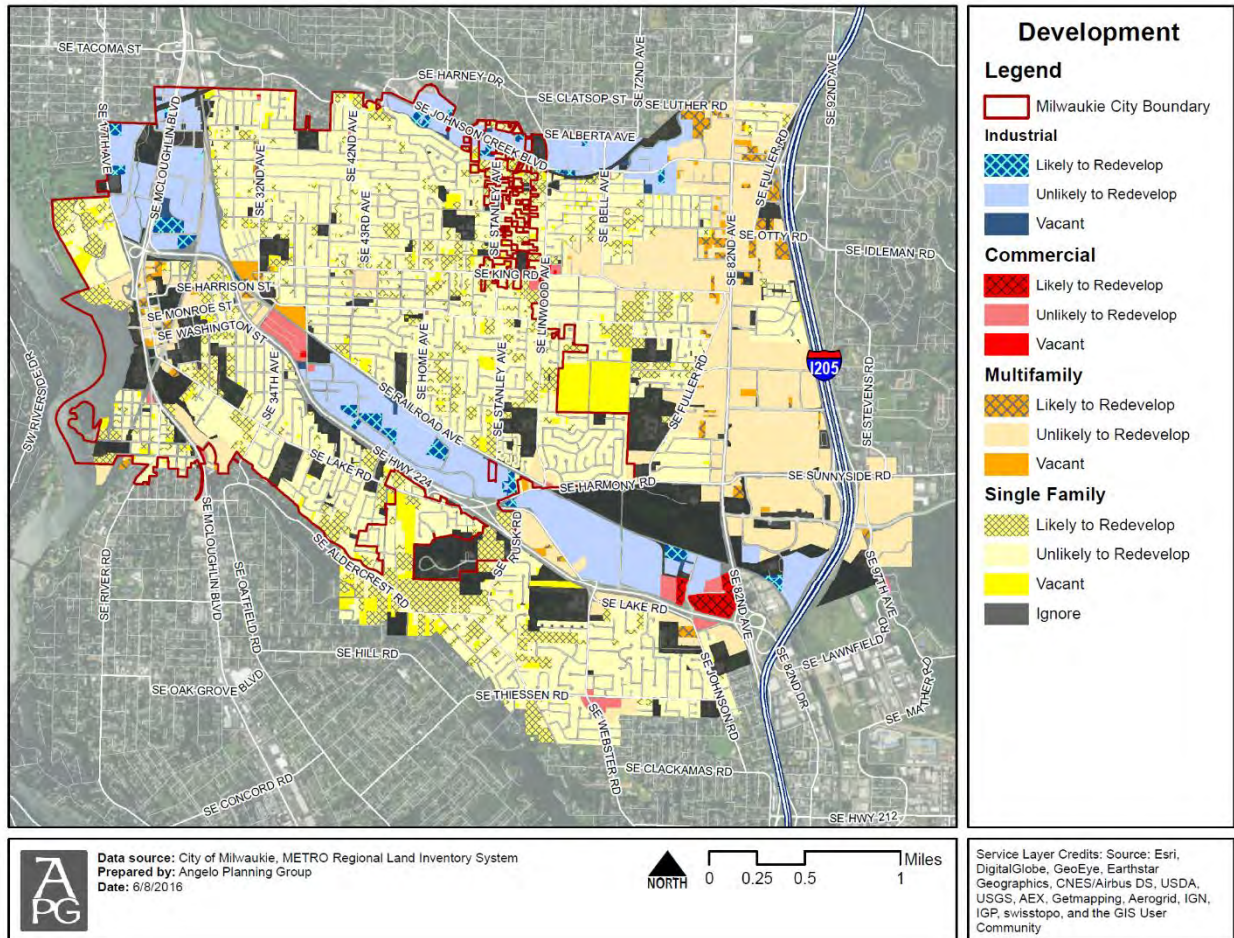
Environmental constraints and related GIS layers are assumed to be unchanged. Taxlot geographies and developable acreage from the previous effort will also be used and updated in specific areas where development activity is known to have occurred or where there have been other changes in land use since 2016.

- **Step 2** of the 2016 BLI calculated the following:
  - Right Of Way (ROW) set-asides for vacant property based on taxlot size and zoning designation
  - Development capacity of vacant taxlots in Single Family Residential (SFR) zones using the Metro BLI methodology



- Infill capacity of developed taxlots based on their current size and the minimum size for their zoning designation
- Development capacity of vacant parcels with multifamily and mixed-use zoning designations, depending upon the amount of environmental constraints on the land
- Redevelopment potential and capacity of developed properties with multifamily and mixed-use zoning, using filters of “strike price” per square-foot of taxlot area.
- Employment acreage for commercial and industrial zones

Figure 1. Map of 2016 Buildable Lands Inventory Results



### Definition of 2019 Scenarios

The City of Milwaukie wishes to evaluate the potential impacts on needed infrastructure facilities (particularly water and wastewater distribution systems) of different development scenarios. The scenarios vary by the location and intensity of future development, as well as assumptions related to development of “dual interest areas” which are currently outside the city limits but which may be annexed into the City of Milwaukie in the future.

Following is a list of scenarios evaluated for this effort:

1. **Low Growth** – assumes partial buildout of Milwaukie’s urban area with development occurring at existing allowed densities and current projected mix of housing types
2. **Medium Growth** – assumes full buildout at existing allowed densities and current projected mix of housing types
3. **Expanded Geography** – assumes full buildout at existing allowed densities and current projected mix of housing types within existing urban growth boundary and dual interest areas
4. **Hubs and Corridors** – assumes full buildout, with more intensive development in hubs and corridors in terms of allowed densities and mix of housing types
5. **Dispersed Growth** – assumes full buildout, with more intensive development (compared to current zoning regulations) in existing single-family zones (e.g., R5, R7 and R10)

The following table summarizes how different types of development were distributed among different zoning designations in the city’s 2016 Housing Needs Analysis. That analysis generally assumed the following:

1. All single-family detached units would be located in the R-5, R-7 and R-10 zones
2. All medium density housing, including duplexes, three-plexes, four-plexes, and townhouses would be located in the R-2, R-2.5 and R-3 zones.
3. All multi-family units (units in attached structures of 5 units or more, excluding townhomes) would be located in the R-1, R-1B and mixed use (DMU, GMU, and NMU) zones.

Table 1. Estimated Buildable Lands Capacity by Residential Unit, Milwaukee Housing Needs Analysis (2016)

CITY OF MILWAUKIE CAPACITY	Unit Type			TOTAL
	Single Family Detached	Medium-Density Attached*	Multi-Family	
<b>SFR Zones</b>				
R-5	244			244
R-7	680			680
R-7PD	0			0
R10	139			139
R-10PD	21			21
OS	6			6
<b>MDR Zones</b>				
R-2		608		608
R-2.5		0		0
R-3		473		473
R-3		0		0
<b>MFR &amp; MUR Zones</b>				
R-1			0	0
R-1-B			52	52
DMU			441	441
GMU			181	181
NMU			74	74
<b>Totals:</b>	<b>1,090</b>	<b>1,081</b>	<b>748</b>	<b>2,919</b>

\* Medium Density Residential (MDR) units include single-family attached (townhomes) to four-plexes. Multi-family Units (MFR) are defined as units in attached structures of 5 units or more.

Source: City of Milwaukee, Angelo Planning Group, Metro

The following tables summarize a potential set of assumptions related to the distribution of housing types for the scenarios described at the beginning of this section.

Table 2. Housing Distribution Assumptions, Low and Medium Growth Scenarios (P – Permitted use, CU – Conditional Use)

Zone	Single-family detached	Duplex	Tri-plex, Four-plex, cottage cluster housing	Townhomes	Multi-family
R-5, R-7, R-10	P	P			
R-2, R-2.5, R-3	P	P	P	P	P (CU)
R-1, R-1B	P	P	P	P	P
NMU	CU	CU	CU	CU	CU
GMU			P	P	P
DMU			P	P	P

*Table 3. Housing Distribution Assumptions, Hubs and Corridors Scenario (P – Permitted use, CU – Conditional Use)*

Zone	Single-family detached	Duplex	Tri-plex, Four-plex, cottage cluster housing	Townhomes	Multi-family
<b>R-5, R-7, R-10</b> <sup>1</sup>	P	P	P	P	
<b>R-2, R-2.5, R-3</b> <sup>2</sup>	P	P	P	P	P
<b>R-1, R-1B</b>	P	P	P	P	P
<b>NMU</b> <sup>3</sup>		P	P	P	CU
<b>GMU</b>			P	P	P
<b>DMU</b>				P	P

Notes:

1. Attached housing types allowed within Hubs and Centers currently located in low density zones
2. Multi-family allowed within Hubs and Centers currently located in R-2, R-2.5 and R-3 zones, if applicable (as stand-alone residential or as part of mixed use developments)
3. Attached housing allowed within Hubs and Centers located in existing or proposed future NMU zones

*Table 4. Housing Distribution Assumptions, Dispersed Growth Scenario (P – Permitted use, CU – Conditional Use)*

Zone	Single-family detached	Duplex	Tri-plex, Four-plex, cottage cluster housing	Townhomes	Multi-family
<b>R-5, R-7, R-10</b> <sup>1, 2</sup>	P	P	P	P	
<b>R-2, R-2.5, R-3</b>	P	P	P	P	P (CU)
<b>R-1, R-1B</b>	P	P	P	P	P
<b>NMU</b>		P	P	P	CU
<b>GMU</b>			P	P	P
<b>DMU</b>				P	P

Notes:

1. Tri-plexes and four-plexes allowed in R-5, R-7 and R-10 zones under certain conditions related to location (e.g., corner lots, proximity to transit, etc.) and/or subject to unit size, floor area or other standards limiting overall size and bulk.
2. Townhomes allowed in R-5 zones.

These policy-level assumptions will be translated into numerical assumptions as described in the following sections.

## Changes to Infill Development Assumptions in Single Family Zones

Table 5 describes the methodology for assessing infill capacity in single-family zones for the 2016 BLI, and proposes changes for the 2019 evaluation.

Table 5. Infill Development Methodology for Single Family Zones

2016 Infill Methodology	2019 Infill Methodology
Screen out apartments in Metro Multifamily Inventory	The Metro Multifamily Inventory has been updated and now includes additional items such as duplexes, triplexes, and ADUs. This analysis has removed triplexes, quadplexes, apartments, manufactured homes, and condos.
<b>Infill Trigger</b>	
Establish size categories: Under 2.5x minimum lot size, between 2.5 and 5x minimum lot size, greater than 5x minimum lot size	Minimum lot sizes will change in Scenario 4 to address re-zoning of hubs and corridors, and Scenario 5 to approximate greater dispersed infill.
Redevelopment trigger of \$150k building value in the 2.5-5x size category	Update building information from latest RLIS data. For Scenario 5, increase trigger price to \$200k. This would mean large taxlots are assumed to redevelop even at a 33% higher building value.
Taxlots greater than 5x in size are within infill inventory	No change – large taxlots are still in the infill inventory
<b>Infill Assumptions</b>	
Number of new infill units was the lesser of: Number of lots allowed to be subdivided by the zone, or unconstrained area divided by 2000 sf.	The number of lots under these assumptions remains accurate. However, there is an increased likelihood that infill will take the form of middle housing with greater than one unit. Such infill development is an intended outcome of HB2001 and City policy changes.
	New 2019 Assumption: Assume a certain percentage of single-family homes in the “Under 2.5x” category redevelop into duplexes. Varying this percentage may yield useful scenarios for planning purposes.

## Up-zoning and development/redevelopment of Hubs and Corridors

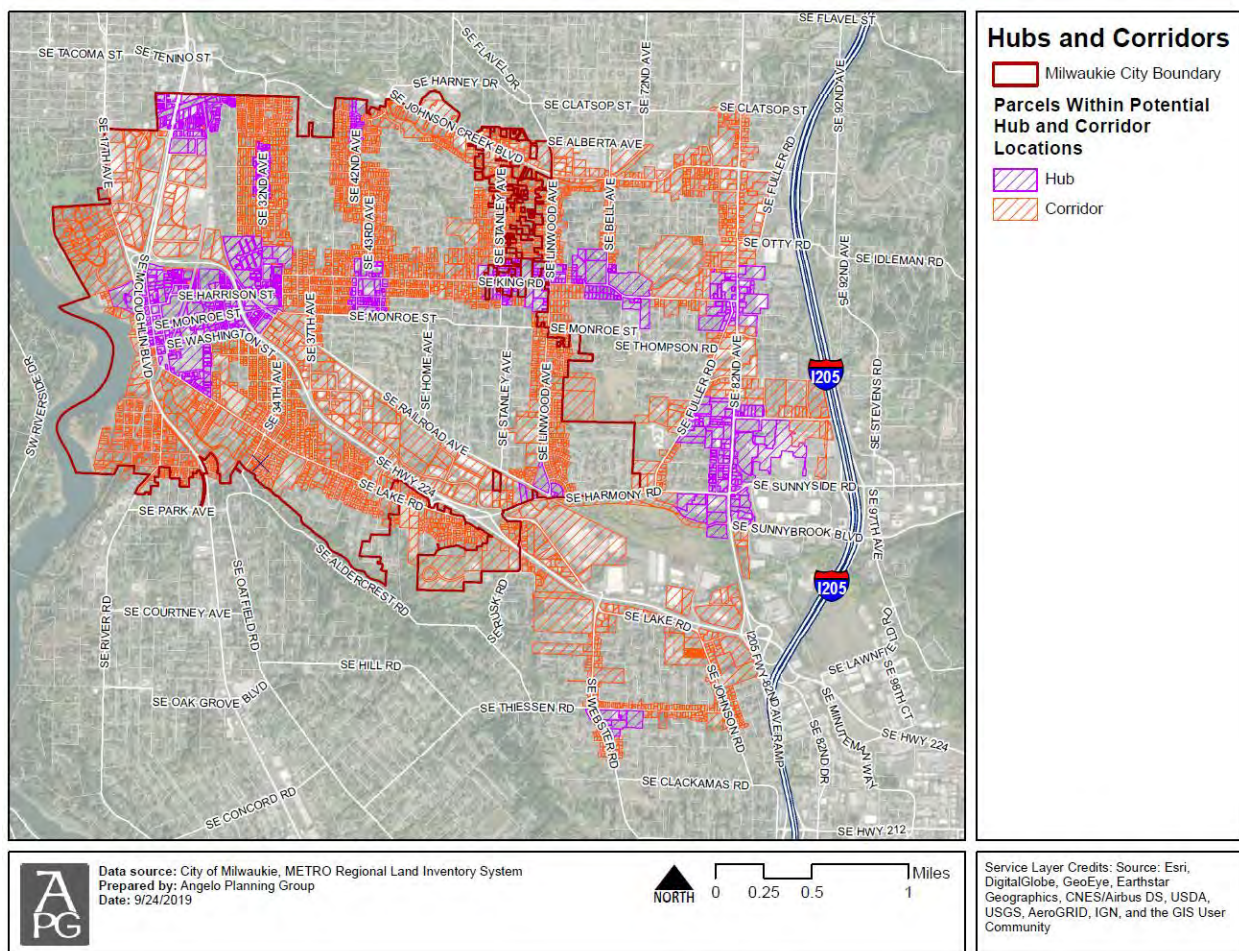
City staff have helped identify parcels that may be subject to up-zoning or an overlay due to the “Neighborhood Hubs and Corridors” element of recent Comprehensive Plan Update work. The intent of these presumed changes is to enhance growth opportunities in areas that serve as neighborhood hubs for surrounding low-density residential areas in part to allow increased density along major corridors of the City that are accessible by transit and provide a higher level of other amenities.



For the purposes of this planning effort, areas within Neighborhood Hubs are assumed to have the characteristics of the **Neighborhood Mixed Use (NMU) zone**, and parcels within Corridors are assumed to have the characteristics of the **R-1 Zone** (where zones are categorized as Single Family - parcels that are already higher density are unchanged). The allowed density range in R-1 is 25-32 dwelling units per acre – the analysis assumes a lot size of 1,500 sf to approximate this range. Note that rezoning, incentives, or some other combination of actions can be used to achieve this result, but the specific mechanisms to achieve these densities are not explored further as part of this analysis.

The map of neighborhood hubs and corridors is shown in Figure 1.

Figure 1. Map of Parcels within Potential Hub and Corridor Locations



## INITIAL ANALYSIS RESULTS

Initial results of the scenario analysis are presented in the maps and tables in this section. GIS data, spreadsheets, and other materials will be provided to help City staff interpret these results and refine the analysis.



Figure 2 shows the development status of land within the study area. Vacant land is assumed to develop at densities determined by underlying zoning designations, while developed land is subject to further screening to evaluate whether there is potential for infill development or redevelopment. Parcels with a status of “Ignore” include parks and open space, religious or fraternal organizations, and government-held property.

Figure 3 depicts the type of land within the study area, grouped into general categories of residential, mixed use, commercial, industrial, and ignore.

Figure 2. Development Status of Land Within the Study Area

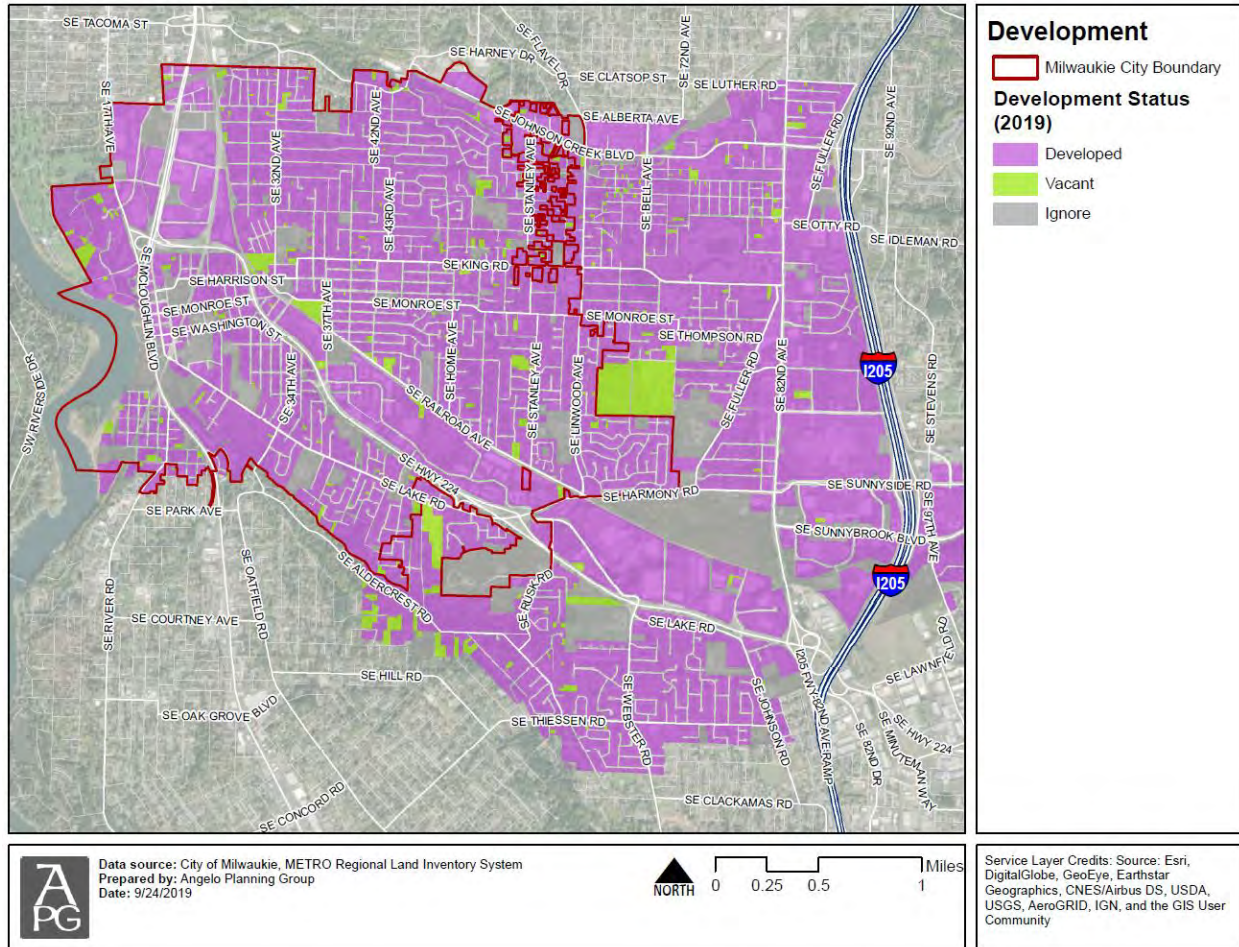
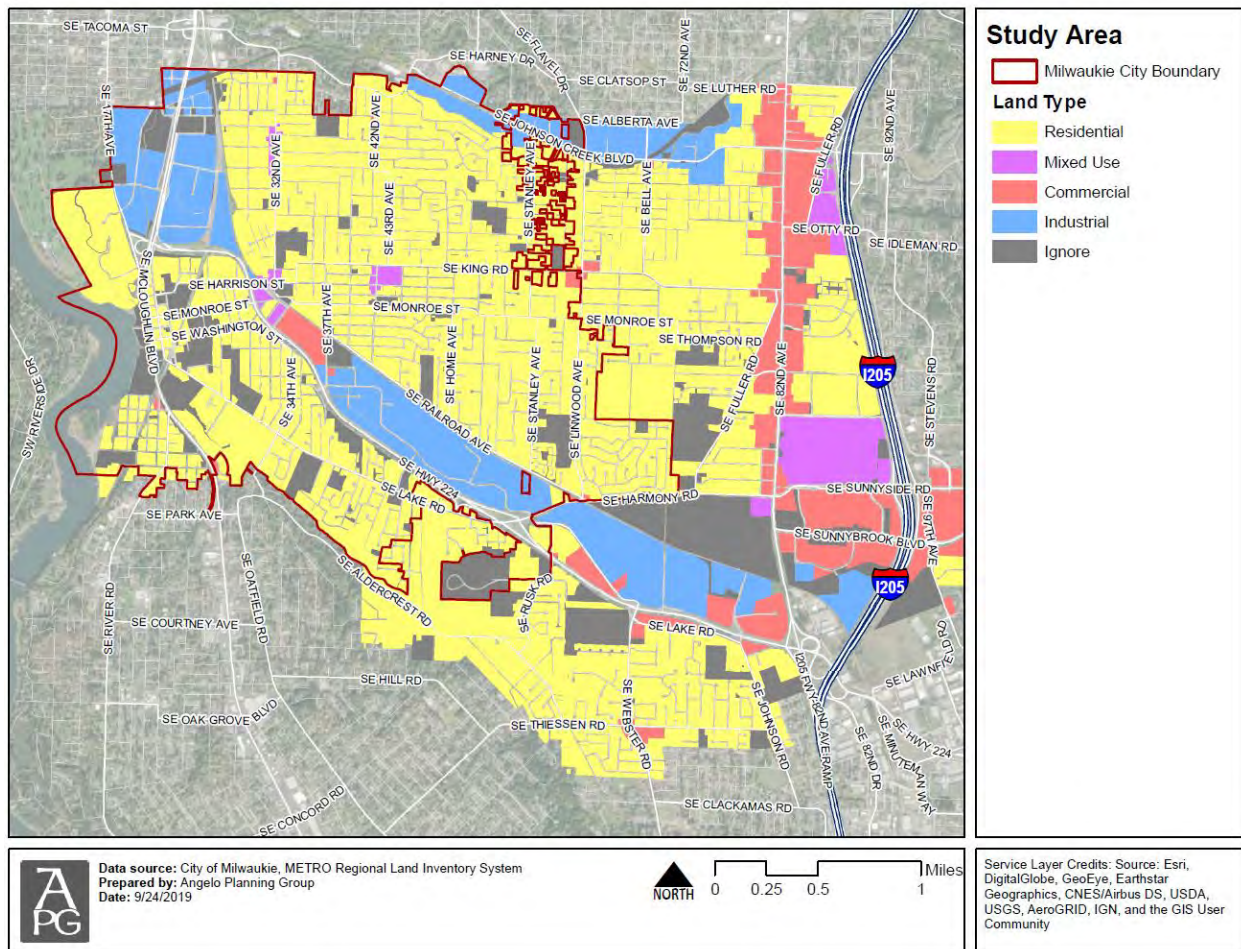


Figure 3. Existing Land Type



The following sections describe Scenarios 1 through 5 with illustrative maps and key findings from the analysis, followed by a summary table (Table 6) for all scenarios.

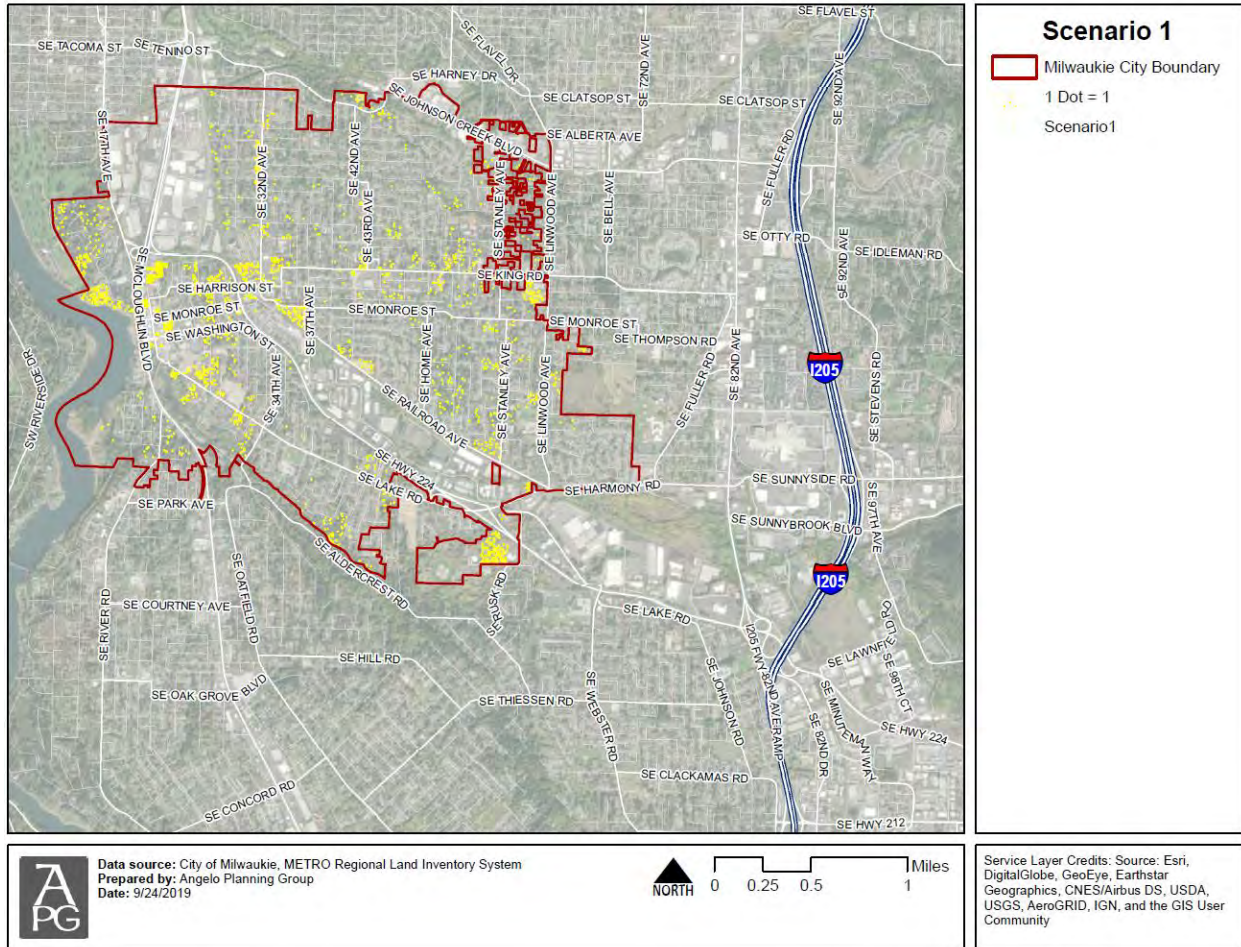
### Scenario 1: Low Growth

Figure 4 depicts new growth, consistent with an assumed partial buildout of Milwaukie’s urban area, where development is expected to occur at existing allowed densities and current projected mix of housing types.

Each yellow dot represents one new unit. Scenario 1 includes areas within the existing City Limits using the assumptions of the 2016 Buildable Lands Inventory, with minor updates. The capacity of parcels showing greater than one new unit in the Medium Growth Scenario have been reduced by 20% across the board to arrive at this result



Figure 4. Initial Results Map of Scenario 1 – Low Growth



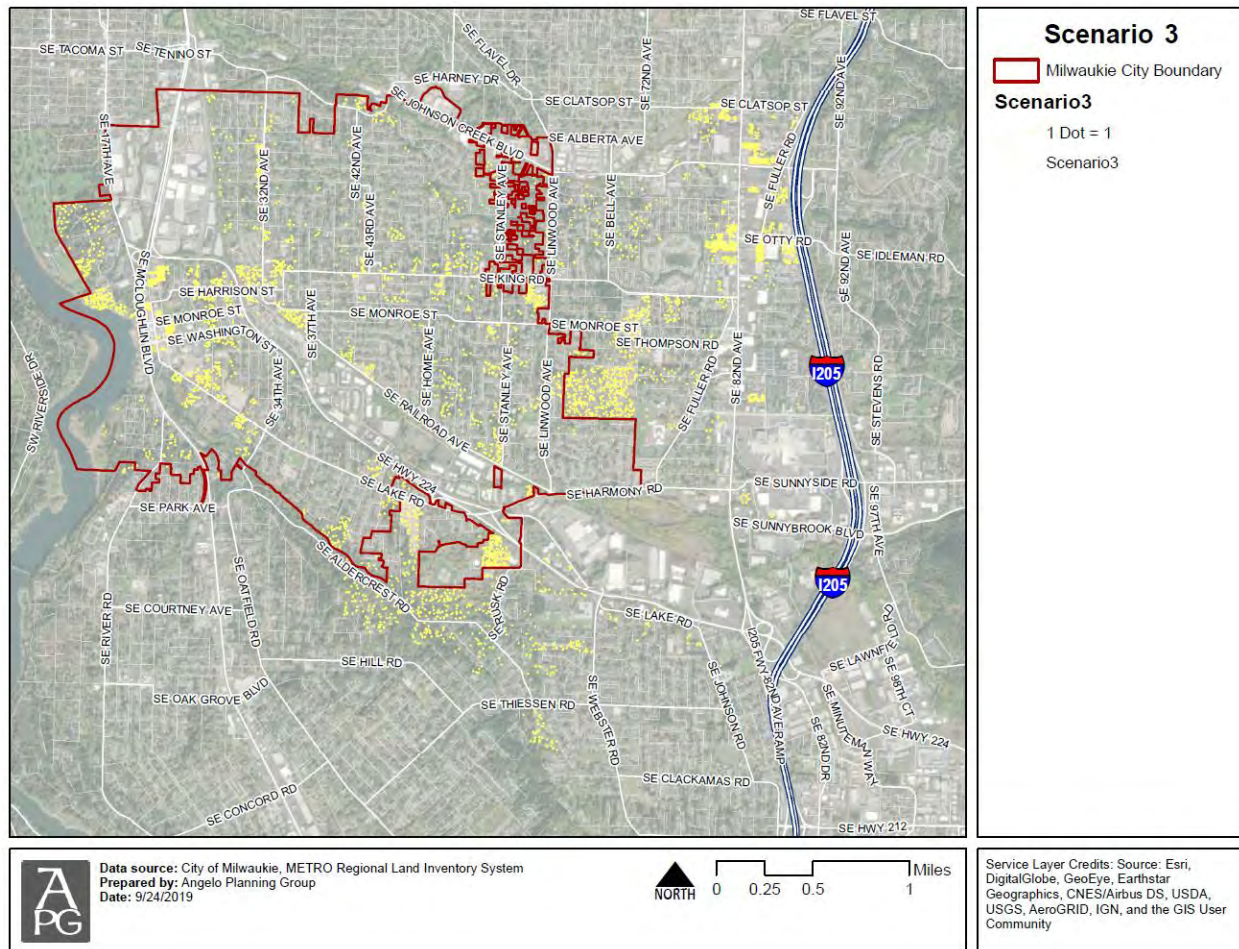
### Scenario 2: Medium Growth

Scenario 2 assumes full buildout at existing allowed densities and current projected mix of housing types; Figure 5 reflects these assumptions. This includes areas within the existing City Limits using the assumptions of the 2016 Buildable Lands Inventory, with minor updates.





Figure 6. Initial Results Map of Scenario 3 – Expanded Geography

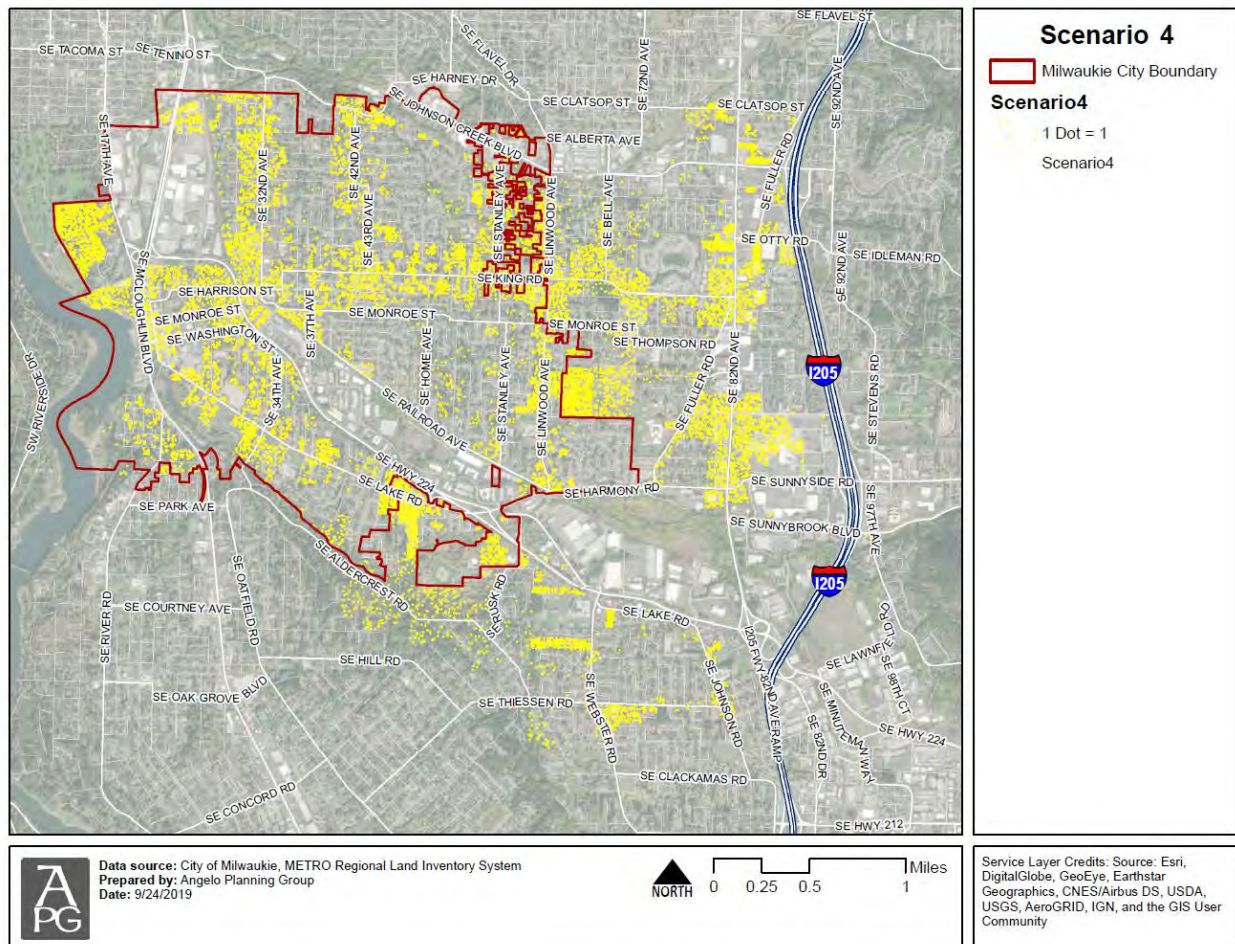


### Scenario 4: Hubs and Corridors

This scenario assumes full buildout, with more intensive development in hubs and corridors related to allowed densities and mix of housing types. Figure 7 depicts new growth consistent with Scenario 4 assumptions. Significant changes are assumed to land abutting high-frequency transit corridors and specific hubs where those corridors intersect. The following assumptions were applied:

- Land within hubs and corridors with greater than .25 acres of unconstrained land is assumed to generate infill.
- Hubs are given a mix of 50% residential and 50% employment acreage. Residential uses and densities of the Neighborhood Mixed Use (NMU) zone are assumed.
- Corridors are given a mix of 100% residential; R-1 zone uses and densities are assumed.
- Mixed use lots are given the same number of units as in the 2016 inventory. Parcels in the Downtown Mixed Use (DMU) zone are unchanged from the 2016 inventory.

Figure 7. Initial Results Map of Scenario 4 – Hubs and Corridors



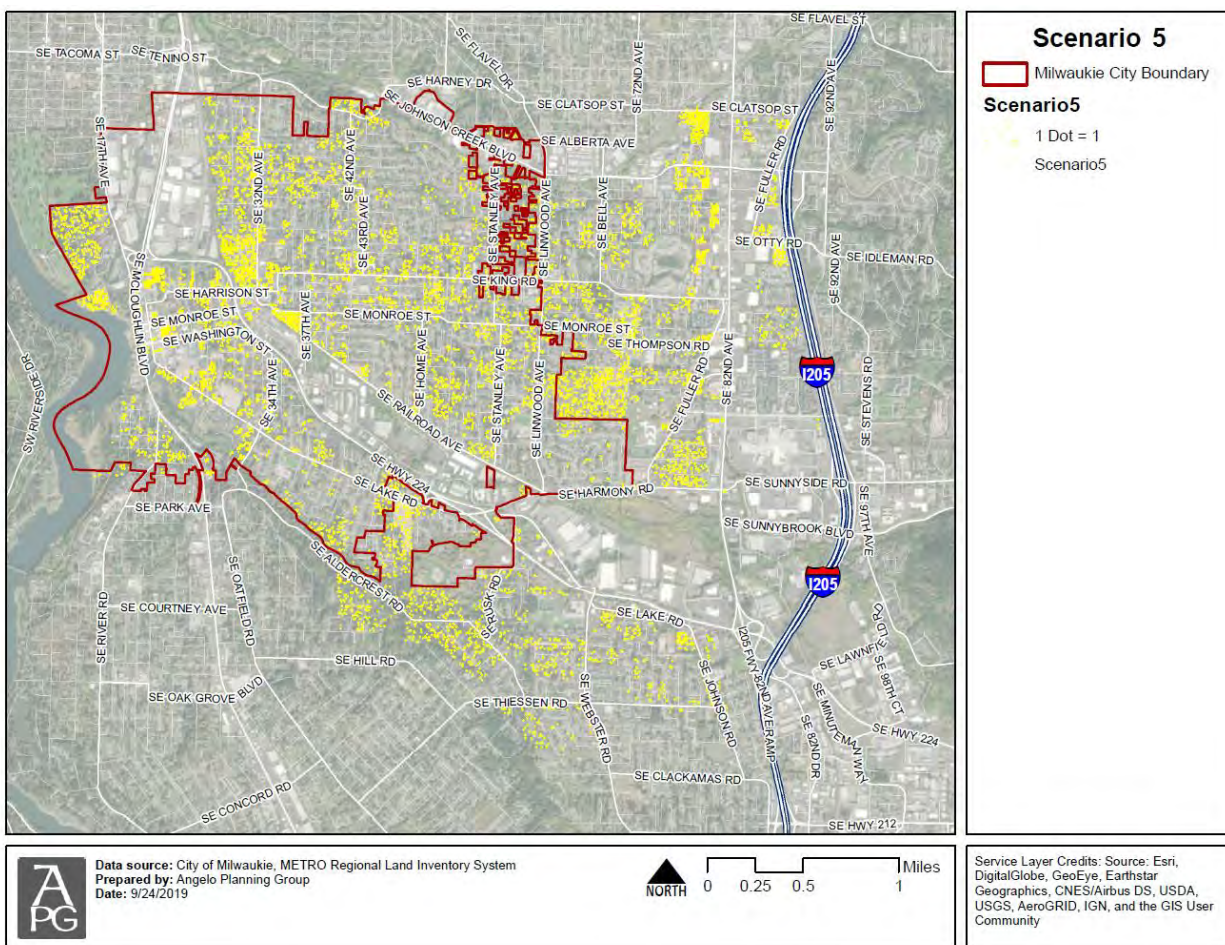
### Scenario 5: Dispersed Growth

This scenario assumes full buildout, with more intensive development (compared to current zoning regulations) in existing single-family zones. Figure 8 depicts new growth as part of Scenario 5 – Dispersed Growth. This scenario is similar to Scenario 3 – Expanded Geography with the following changes:

- Building value cutoff for redevelopment is now at \$200,000, rather than \$150,000.
- Policy changes related to House Bill 2001 and other middle-housing policies are approximated by changing minimum lot sizes for the following zones:
  - o R-10: 10,000 sf to 6,000 sf
  - o R-8.5: 9,000 SF to 6,000 SF
  - o R-7: 7,000 SF to 5,000 SF
  - o R-5: 5,000 SF to 3,500 SF
- Size ratio above 2x min lot size and value below \$200k is the trigger for redevelopment.
- Mixed use lots are given the same number of units as the 2016 inventory. Parcels in the DMU zone are unchanged from the 2016 inventory.



Figure 8. Initial Results Map of Scenario 5 – Dispersed Growth



The overall draft results of the analysis are shown in Table 6, where scenario projections are shown by existing zoning.

Initial takeaways of the analysis are listed below:

- Scenario 1 and Scenario 2 show modest growth of approximately 2,000 units within the City under current trends.
- Vacant land comprises a small fraction of the available buildable land capacity within the City of Milwaukie – infill and redevelopment make up the majority of development in all scenarios.
- Scenario 4 shows the most growth, far exceeding the other Scenarios. This may be an indication that the growth assumptions are too aggressive. Reducing the geography of corridors/hubs, adjusting filters to trigger redevelopment on fewer lots, or reducing the assumed Corridor zone from R-1 densities could be considered to approximate a more realistic future outcome.

- Some individual parcels that are likely to be built at higher density housing under Scenario 3 are indicating less potential development in Scenario 4, due to the 50% employment land assumption for neighborhood hubs. This can be examined more closely in future iterations of this analysis.
- The initial results, as shown in the previous maps, specific parcels and neighborhoods stand out as growth opportunities. These geographies can be critiqued in more detail to test and verify the assumptions; parcels can then be added/removed from the inventory on a case-by-case basis.

Table 6. Initial Results

	Scenario 1	Scenario 2	Scenario 3	Scenario 4	Scenario 5
<b>Total Units</b>	<b>1,855</b>	<b>2,264</b>	<b>4,586</b>	<b>15,292</b>	<b>9,916</b>
Units Within City Limits	1,843	2,249	2,249	8,995	5,710
Units within Dual Interest Areas	12	12	2,337	6,297	4,206
Units within Commercial Zones	0	0	786	1,638	36
Units within Industrial Zones	0	0	0	166	0
Units Within Mixed Use Zones	89	111	256	991	263
Units within Residential Zones	1,766	2,153	3,544	12,497	9,617

## NEXT STEPS

These initial results will be reviewed by City staff and updates to this analysis are expected. APG can provide GIS data, spreadsheets, or other information to help staff review.

# Appendix E. Flow Monitoring Technical Memorandum

# Technical Memorandum



**Date:** 10/2/2020

**To:** Peter Passarelli  
City of Milwaukie  
6101 SE Johnson Creek Blvd  
Milwaukie, OR 97206

**Phone:** (503) 786-7614

**Prepared by:** Adam Donald, P.E.

**Reviewed by:** Scott Duren, P.E.

**Project:** 2019 Wastewater System Master Plan

**SUBJECT: FLOW MONITORING SUMMARY AND RECOMMENDATIONS**

---

In accordance with the scope of services described in Task 4.0 of Agreement C2019-038 between Water Systems Consulting, Inc. (WSC) and the City of Milwaukie (City), this technical memorandum (TM) provides an overview of the flow monitoring conducted in the spring of 2019 and winter of 2019/2020, summarizes the flow monitoring results, and recommends next steps for the using the flow monitoring results.

## 1 Introduction

Water Systems Consulting, Inc. (WSC) subcontracted with SFE Global to conduct sanitary sewer flow monitoring and rainfall monitoring in the City of Milwaukie (City) over a 5-week period from May 2 to June 4, 2019 at six (6) open-channel flow monitoring sites. The purposes of this study were to:

1. Establish baseline sanitary sewer flows for each of the City's sanitary sewer basins.
2. Better characterize the effects of I/I at each monitored location.

The lack of a significant rainstorm during the initial flow monitoring period resulted in the need for a second round of flow monitoring. SFE redeployed flow monitors over a 14-week period from November 18, 2019 to February 20, 2020 to capture wet weather data.

## 2 Flow Monitoring Sites, Sewerage Basins and Rain Gauges

In accordance with Task 4.1 of the scope of services, WSC established an initial flow monitoring plan to identify the ideal locations for capturing flow within each of the City's sewerage basins. The initial flow monitoring plan is attached as Appendix A. When selecting the locations for flow monitors, WSC considered manholes that met the following criteria:

- Located at the lowest point of capture for each basin;
- Contain no active junctions (did not have multiple inlet pipes with active flow);
- Do not receive flow from areas outside of the City sewer service area;
- Minimize the need for traffic control; and
- Accessible by SFE Global and City staff (capable of parking truck within 200 ft of manhole).

Flow monitors were selected to monitor flow within the following sewerage basins:

- North Milwaukie
- Mid Milwaukie
- South Milwaukie
- Brookside Basin
- Harmony Basin

Flow monitors were not deployed within the Lower Kellogg Basin and Johnson Creek Basin. The Lower Kellogg interceptor drains the Lower Kellogg Basin but its infrastructure is owned by Clackamas Water Environmental Services (WES) and receives flow from service areas outside of the City. A flow monitor was not placed within the Lower Kellogg interceptor as it would not provide useful model calibration data specific to the City service area. Similarly, a flow monitor was not placed in the Johnson Creek Basin as the basin discharges into the City of Portland’s Lents Interceptor at multiple points. Since the Lents Interceptor contains flows outside of the City’s service area, a flow monitor would not provide useful model calibration data specific to the City service area. For the purposes of building the model, the flow meter for the Brookside Basin (FM1) will be used to develop loading patterns for the combined area of the Brookside Basin and Johnson Creek Basin due to their proximity. Similarly, the flow meter for the Southern Milwaukie Basin (FM4) will be used to develop loading patterns for the Lower Kellogg Basin due to their vicinity and similar land use types.

Two flow monitors were installed within the Harmony Basin. The collection system within the Harmony Basin is configured such that the western portion of the basin collects wastewater from primarily commercial and industrial customers while the eastern portion of the basin collects wastewater from primarily residential customers. These two trunk mains converge at the southeastern end of the basin prior to flowing through Clackamas WES Harmony Flow Meter and into WES’ collection system. The configuration created an opportunity to have representative flows from residential and commercial/industrial customers that can be used to calibrate flow factors by land use.

Following completion of the final draft of the flow monitoring plan, a site walk was conducted with SFE Global’s installation crew, the City’s lead wastewater utility technician, and WSC to confirm and mark the selected manholes for flow meter installation. During this site walk, the initially selected manholes for the North Milwaukie Basin and Mid Milwaukie Basin were identified as inaccessible by the City. The adjacent manholes meeting the selection criteria were selected for their replacement. The final flow monitoring locations are shown in Figure 2-1 and Table 2-1. Detailed descriptions of the flow monitoring sites, including photographs, are included in Appendix B.

*Table 2-1: Flow Monitor Sites and Sewerage Basin Sizes*

Flow Monitor Site	Pipe Monitored	Diameter (inches)	Location	Sewerage Basin	Basin Area Monitored (Acres)
<b>FM1</b>	Inlet	12	4517 SE Brookside Dr.	Brookside	242
<b>FM2</b>	Inlet	24	Near 1906 SE Monroe St.	N. Milwaukie	1224
<b>FM3</b>	Inlet	21	Near 10966 SE McLoughlin Blvd	Mid Milwaukie	615
<b>FM4</b>	Inlet	15	Near 119218 SE 22 <sup>nd</sup> Ave	S. Milwaukie	121
<b>FM5</b>	Inlet	14	Near 5989 SE Harmony Rd	Harmony	365
<b>FM6</b>	Inlet	15	Near 12486 SE 60 <sup>th</sup> Ct	Harmony	412



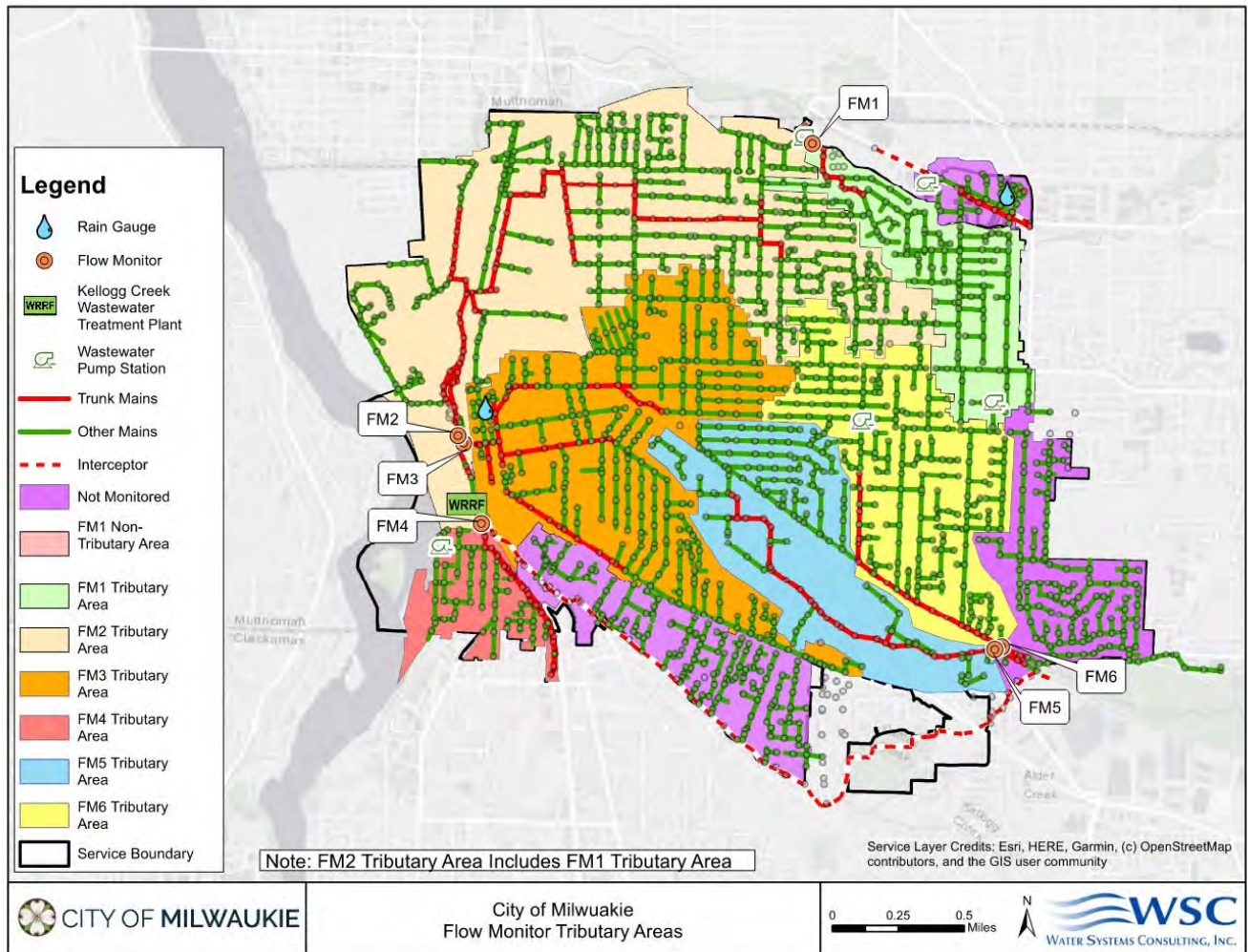


Figure 2-1: City Sewerage Basins and Flow Monitor Locations

Rain gauges were installed by SFE Global at City Hall and the City’s Public Works building, as shown in Figure 2-1. Rain gauges require a relatively flat area for installation and are best installed in areas that are inaccessible to the general public to prevent tampering. City Hall and the Public Works building both met these criteria and are located on opposite sides of town to provide a more complete understanding of rain distribution throughout the City. These buildings are City-owned, which did not require any additional agreements for use of the land for placing the rain gauges.

### 3 Methods and Procedures

SFE Global provided and installed the flow monitors and rain gauges for the initial flow monitoring. As discussed in Section 2, a site walk was performed with the SFE Global installation crew, the City, and WSC to confirm the final flow monitoring locations based on the final draft of the initial flow monitoring plan. During this site walk, SFE Global evaluated each manhole to take measurements, determine style of flow meter required, determine traffic control requirements, and mark the manholes to avoid any confusion on installation day.

Flow monitors were installed by SFE Global’s installation crew on May 2, 2019. Installation consisted of standard confined space entry procedures, including the use of a tripod to lower the crew into the manhole to install the

flow meter within the trough. Most of the flow monitoring sites selected were located outside of the right of way, eliminating the need for traffic control. However, Flow Monitor 6 (Near 12486 SE 60<sup>th</sup> Ct) was located along the shoulder of SE Railroad Avenue, which is a high traffic area. Traffic control measures were implemented at this location to safely install the flow monitor.

ISCO 2150 flow monitors were selected for each location. These monitors use an area velocity (AV) module with a pressure transducer to determine flow level and an AV sensor to determine velocity within the pipe. The AV module unit then calculates the flow rate and total flow data based on these measurements. A transmitter was installed within each manhole that wirelessly transmits this data to a cloud-based server. A local copy of the data is stored within the AV module in the event that the data transmission fails. Figure 3-1 shows the final configuration of the installed flow meter assembly as well as a sketch for where the sensors were installed. In locations where significant ragging or sedimentation was anticipated, the sensor was installed in an “offset” position just above the flowline if the pipe. In these locations additional calibration was performed during installation to adjust readings to account for the offset. Descriptions of each installation are provided in Appendix B.

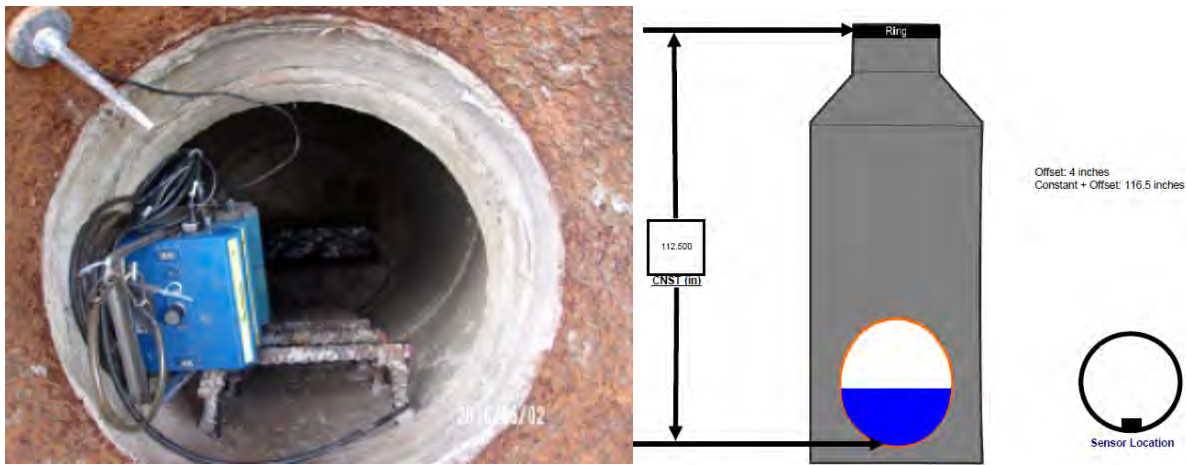


Figure 3-1: Installed Flow Monitor

## 4 Initial Flow Monitoring

### Initial Rainfall Monitoring Results

Rainfall data was collected by two rain gauges on opposite sides of the City throughout the duration of flow monitoring. Rain gauge 1 was located at the City’s Public Works Yard and Rain Gauge 2 was located on the roof of the City’s City Hall building, as discussed in Section 2. A summary of the rain data is provided in Table 4-1. Additional rainfall and flow monitoring data is provided in Appendix C. During the flow monitoring period, the maximum storm intensity was measured as 0.23 inches/hour over a 60-minute duration. According to the Oregon Department of Transportation’s Hydraulics Manual, this rainfall intensity correlates to less than a 2-year frequency storm, as shown in Figure 4-1. During the flow monitoring period, rainfall totaled 1.7 inches total and never exceeded 0.4 inches/day. To better characterize rainfall derived infiltration and inflow (RDII) within the system, additional flow monitoring was recommended to be completed during the winter when there is historically rainfall of greater intensity and duration.

Table 4-1: Rain Event Summary For Initial Flow Monitoring

Day	Total Rain (inches)	Peak Rain Intensity (inches per hour)
May 14, 2019	0.1	0.02
May 15, 2019	0.2	0.12
May 18, 2019	0.4	0.23
May 19, 2019	0.4	0.19
May 20, 2019	0.1	0.06
May 22, 2019	0.2	0.14
May 25, 2019	0.3	0.13
<b>Total/Maximum</b>	<b>1.7</b>	<b>0.23</b>

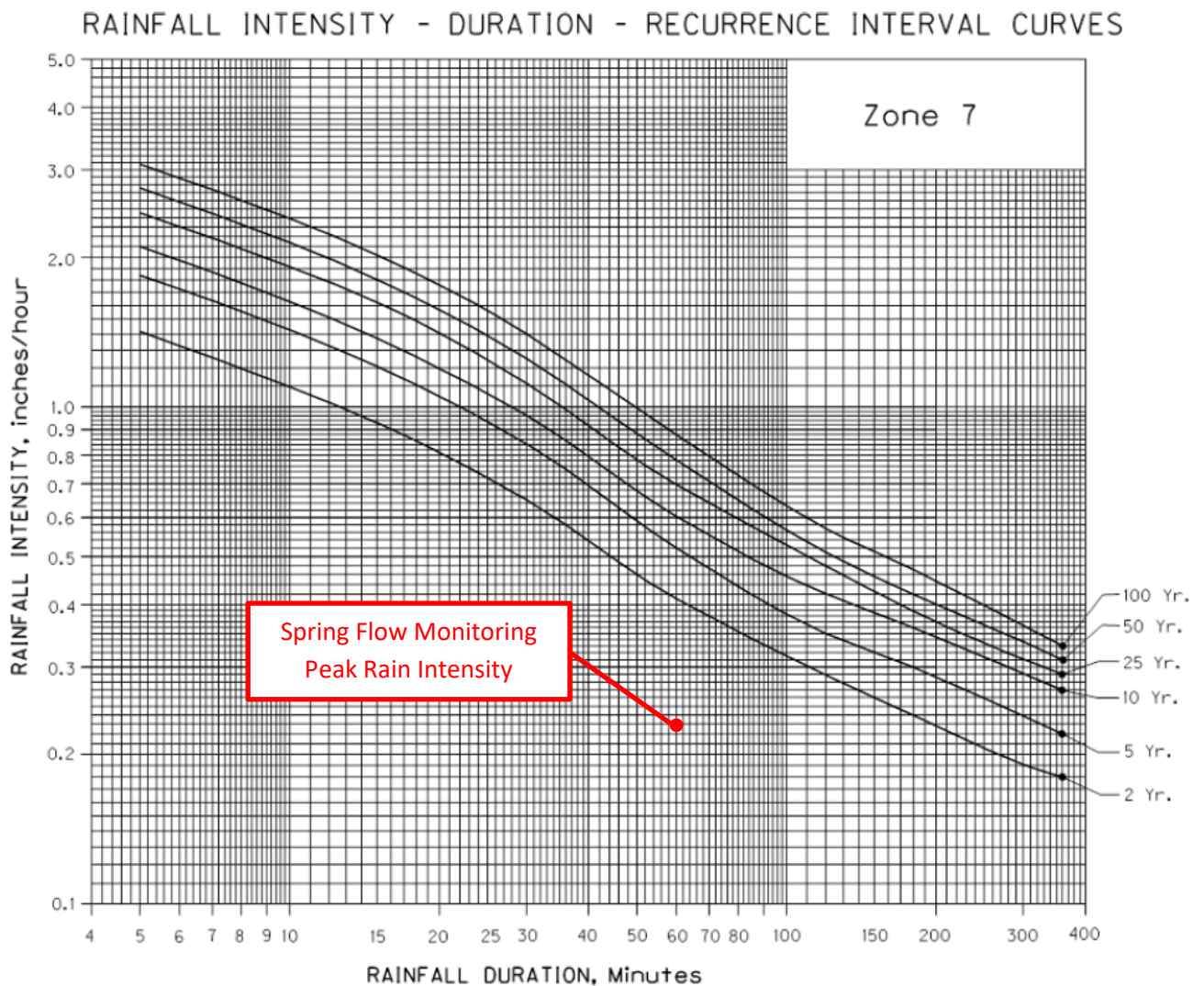


Figure 4-1: ODOT Hydraulic Manual Rainfall Intensity-Duration-Recurrence Interval Curves for Milwaukie (Included in Zone 7) (1)

### Initial Flow Monitoring Results

Flow monitoring data is included in Appendix C. Flow meters recorded data at five-minute intervals throughout the duration of monitoring. The data was used to calculate average dry weather flow (ADWF), peak hourly flow (PHF), and a peaking factor for each basin area monitored. These results are presented in Table 4-2. ADWF was 10/2/2020



determined by averaging all meter readings for days when there was no recorded rain, with the exception of the day after a rain event. Following a storm, there is a lag time as the water from the rain event makes its way through the watershed and infiltrates into the soil. The day after any rain event was excluded from the ADWF calculation to account for this and allow time for the soils to dry out, reducing the influence from RDII. PHF was determined by taking the maximum value of the hourly flow rates. Hourly flow rates were determined by calculating the cumulative volume for all five-minute intervals within an hour and then converting to gallons per day. Generally, the PHF occurred on or within three days of a rainstorm. Peaking factors were determined by dividing the PHF by the ADWF. The peaking factor provides insight into the range of flows seen within the system and can be influenced by a number of factors, including RDII, the size of the basin’s tributary area, the proximity to pump stations, or a one-time event (e.g., someone draining a pool). An RDII analysis should be conducted following the additional flow monitoring to characterize the impact of RDII on peak flows within the distribution system.

Table 4-2: Initial Flow Monitoring Results

Flow Meter	Average Dry Weather Flow (gpd)	Peak Hourly Flow (gpd)	Peaking Factor
1	160,692	276,227	1.7
2	473,111	878,230	1.9
3	199,527	435,857	2.2
4	57,013	116,868	2.0
5	441,715	767,502	1.7
6	343,164	754,253	2.2
<b>gpd = Gallons per Day</b>			

During a portion of the flow monitoring work, WES performed work on the Kellogg Creek Water Resource Recovery Facility (WRRF) Influent Pump Station (IPS), which involved modifying pump set points. The raised set points in the WRRF IPS resulted in surcharging within the manhole where Flow Meter 2 was installed. The surcharging within the manhole resulted in reduced velocity data that does not correlate to flowrate. However, the depth data recorded by the meter was still usable. Flows were manually calculated using the depth in accordance with the Manning’s Equation for this location.

## 5 Wet Weather Flow Monitoring

The initial flow monitoring results provided adequate data for verifying the flows in the system model to observed dry weather flow conditions. However, characterization of RDII should ideally occur during a series of storms that stress the collection system. “System stressing events are typically more than one inch of rainfall in a 24-hour period.” (2) During the initial flow monitoring period, no storm exceeded 0.4 inches of rainfall in a 24-hour period. Due to lack of rain intensity, flow monitors and rain gauges were redeployed by SFE from November 18, 2019 to February 20,2020 to capture wet weather data. The same flow monitoring plan and procedures were followed for the wet weather flow monitoring as the initial flow monitoring (see Section 2 and Section 3).

### Wet Weather Rainfall Monitoring Results

Rainfall data was collected by two rain gauges on opposite sides of the City throughout the duration of flow monitoring. Rain gauge 1 was located at the City’s Public Works Yard and Rain Gauge 2 was located on the roof of the City’s City Hall building, as discussed in Section 2. A summary of the ten largest storms during the

monitoring period is provided in Table 5-1. Additional rainfall and flow monitoring data is provided in Appendix C. As previously noted, the goal of the wet weather flow monitoring was to capture a series of storms that stress the collection system with one storm having at least one inch of rainfall over a 24-hour period. As shown in Table 5-1, two storms exceeded a total depth of one-inch over 24 hours with the largest storm occurring on January 27-28. Both storms were also preceded by smaller yet frequent storms that allowed for antecedent soil saturation conditions and thus provide valuable data for developing wet weather response unit hydrographs within the sewer hydraulic model..

*Table 5-1: Top 10 Rain Event (24 Hour) by Total Rain During Wet Weather Monitoring*

Period	Total Rain (inches)	Peak Rain Intensity (inches per hour)
<b>January 27, 2020 11:30 am – January 28, 2020 11:30 am</b>	1.30	0.20
<b>December 20, 2019 5:20 pm – December 21, 2020 5:20 pm</b>	1.03	0.09
<b>December 6, 2019 7:25 pm – December 7, 2019 7:25 pm</b>	0.94	0.14
<b>January 23, 2020 8:25 am – January 24, 2020 8:25 am</b>	0.84	0.14
<b>January 10, 2020 11:20 am – January 11, 2020 11:20 am</b>	0.79	0.14
<b>February 15, 2020 2:30 am – February 16, 2020 2:30 am</b>	0.74	0.12
<b>December 18, 2019 7:05 am – December 19, 2019 7:05 am</b>	0.70	0.17
<b>December 11, 2019 12:55 pm – December 12, 2019 12:55 pm</b>	0.64	0.25
<b>January 25, 2020 9:30 pm – January 26, 2020 9:30 pm</b>	0.62	0.18
<b>January 29, 2020 5:30 am – January 30, 2020 5:30 am</b>	0.55	0.12

## Wet Weather Flow Monitoring Results

Wet weather flow monitoring data is included in Appendix C. Flow meters recorded data at five-minute intervals throughout the duration of monitoring. The data was used to calculate PHF and a peaking factor for each basin area monitored. These results are presented in Table 5-2.

Flow monitoring data collected in 5-minute intervals was converted into a total volume of flow in gallons, and then summed to calculate the average flow across each hour in units of gallons per day. Peaking factors were determined using the methodology outlined in Section 4. In reviewing the data, the peak wet weather flow for Flow Monitor 6 was far lower than the peak hourly flow determined in the initial flow monitoring period. In fact, the peak hour flow from the second round of flow monitoring was only about 10% greater than the ADWF calculated in the initial flow monitoring period. All other flow monitors had higher peaking factors during the wet weather monitoring period, indicating there was discrepancy with the data at Flow Monitor 6. WSC compared the flow data from each monitoring period with data at Clackamas WES' Harmony Meter and determined that Flow Monitor 6 was reading high during the initial flow monitoring period. Based on this, WSC revised the ADWF number for Flow Monitor 6 by using the driest period during the second round of flow monitoring (November 18, 2019 to November 22, 2019). This revised ADWF number is shown in Table 5-2 and is used for the peaking factor calculation.



Table 5-2: Wet Weather Flow Monitoring Results

Flow Meter	ADWF (gpd)	Peak Wet Weather Flow (gpd)	Peaking Factor
1	160,692	596,724	3.7
2	473,111	1,656,826	3.5
3	199,527	752,476	3.8
4	57,013	270,357	4.7
5	441,715	1,062,633	2.4
6	203,265 <sup>A</sup>	382,701	1.9

**gpd = Gallons per Day**

**A. Average dry weather flow was modified from the initial flow monitoring period (5/3/19 to 5/14/19) to a dry period in the second round of flow monitoring (11/18/19 to 11/22/19).**

### Scatter Plots

The accuracy and precision of the ISCO 2150 flow monitors can be assessed by plotting the depth of flow versus the measured velocity for each 5-minute interval measurement collected during the monitoring period. The general shape of the plotted points should resemble the curve that would be calculated for the upstream pipe using the Manning’s equation. Offsets or deviations from a Manning’s curve can indicate conditions within the sewer that may impact the accuracy of the meter, such as a sag in the pipe, downstream blockages, flow backing up from a downstream pump station, or a sanitary sewer overflow.

Plots of flow depth versus velocity indicated relatively stable flow conditions for all flow monitors with the exception of Flow Monitor 1. Some of the data for FM 1 indicates increased depth of flow and lowered velocities that appear to indicate the flow at this location is impacted by fluctuating water levels in the Brookside Pump Station wet well. The lead pump is set to turn on when the wet well water surface reaches in the invert of the influent pipe, and the lag pump will turn on when the water surface reaches one foot above the lead pump on elevation. The flow data appears to be valid as the ISCO 2150 unit can utilize both the area velocity and the depth of water to calculate flow, but if future flow monitoring is conducted at this location other types of monitors, such as a radar monitors, will not accurately calculate flow during periods where the backwater from the wet well is influencing velocity and depth within the manhole.

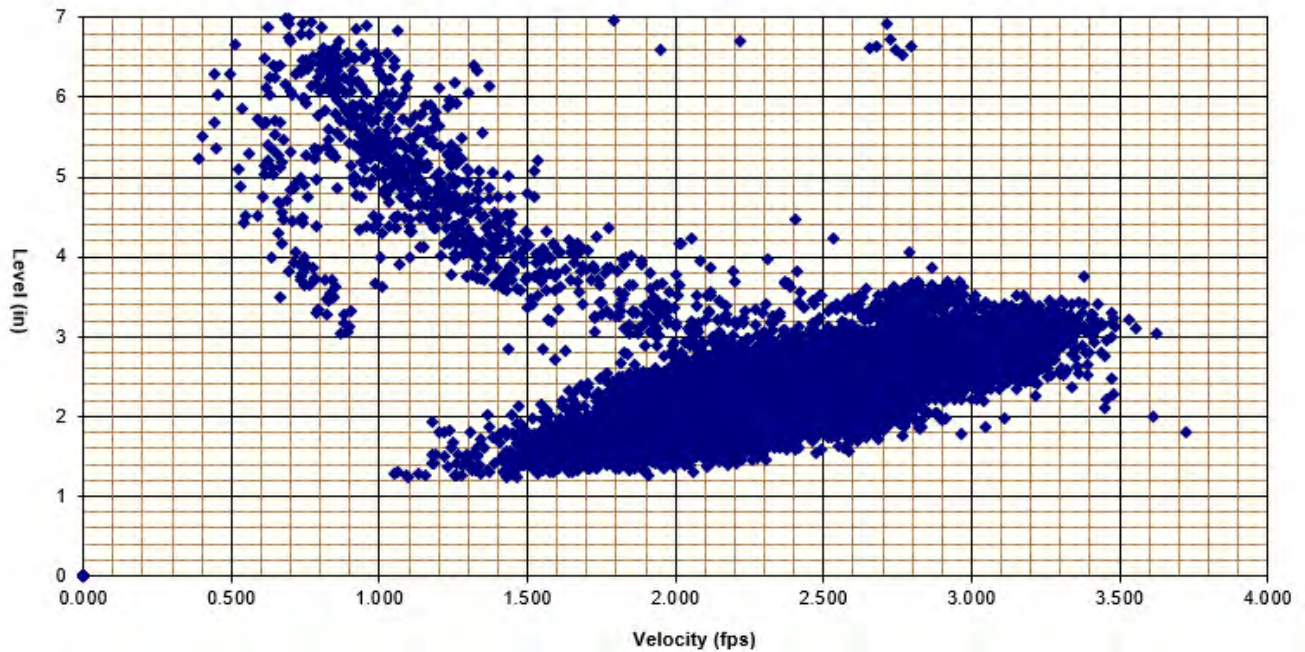


Figure 5-1: Plot of Level versus Velocity for FM 1 between November 2019 and February 2020

## 6 Conclusion

The flow monitoring results provide adequate data for calibrating the system model. Data collected during the initial flow monitoring period will be used to calibrate the model to dry weather flow conditions. The second round of flow monitoring captured storms with total rainfall depth greater than one inch in a 24-hour period, which is sufficient for calibrating the model to wet weather conditions and estimating RDII within the collection system.

## 7 References

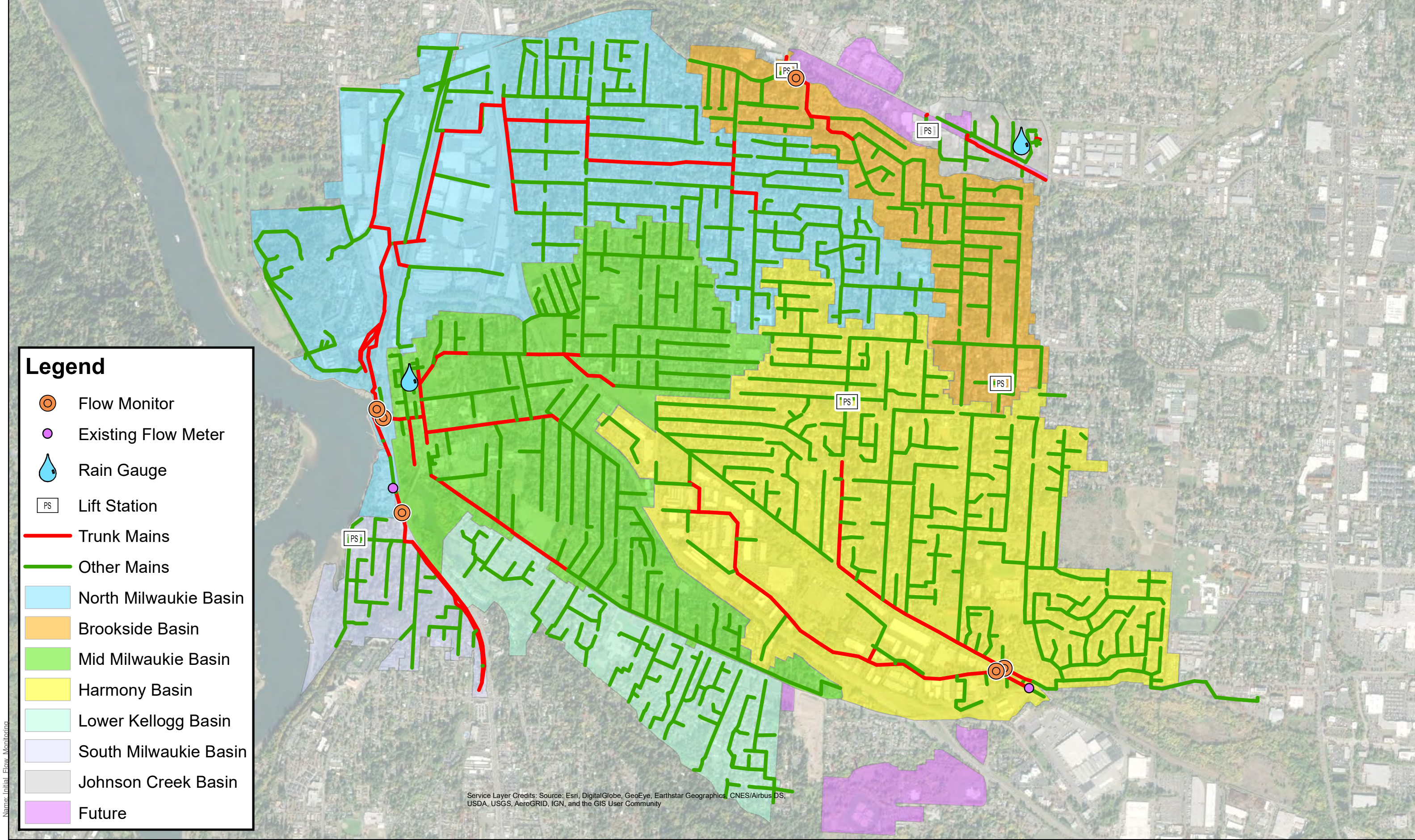
1. **Oregon Department of Transportation (ODOT).** *Hydraulics Manual.* s.l. : ODOT, 2014.
2. *Getting More From Flow Monitoring - Interpreting Sewer Flow Data to Yield the Maximum Benefit.* **Paul S. Mitchell, P.E. and Patrick L. Stevens, P.E.** Huntington Beach, CA : Water Environment Federation, 2005, Vols. Collection Systems 2005 - Sustaining Aging Infrastructure: System, Workforce, and Funding.

















# 8 Appendix A - Flow Monitoring Plan







**Legend**

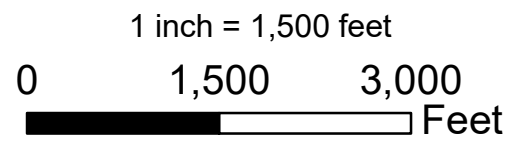
-  Flow Monitor
-  Existing Flow Meter
-  Rain Gauge
-  Lift Station
-  Trunk Mains
-  Other Mains
-  North Milwaukie Basin
-  Brookside Basin
-  Mid Milwaukie Basin
-  Harmony Basin
-  Lower Kellogg Basin
-  South Milwaukie Basin
-  Johnson Creek Basin
-  Future

Service Layer Credits: Source: Esri, DigitalGlobe, GeoEye, Earthstar Geographics, CNES/Airbus DS, USDA, USGS, AeroGRID, IGN, and the GIS User Community

Date: 9/9/2019 Name: Initial Flow Monitoring



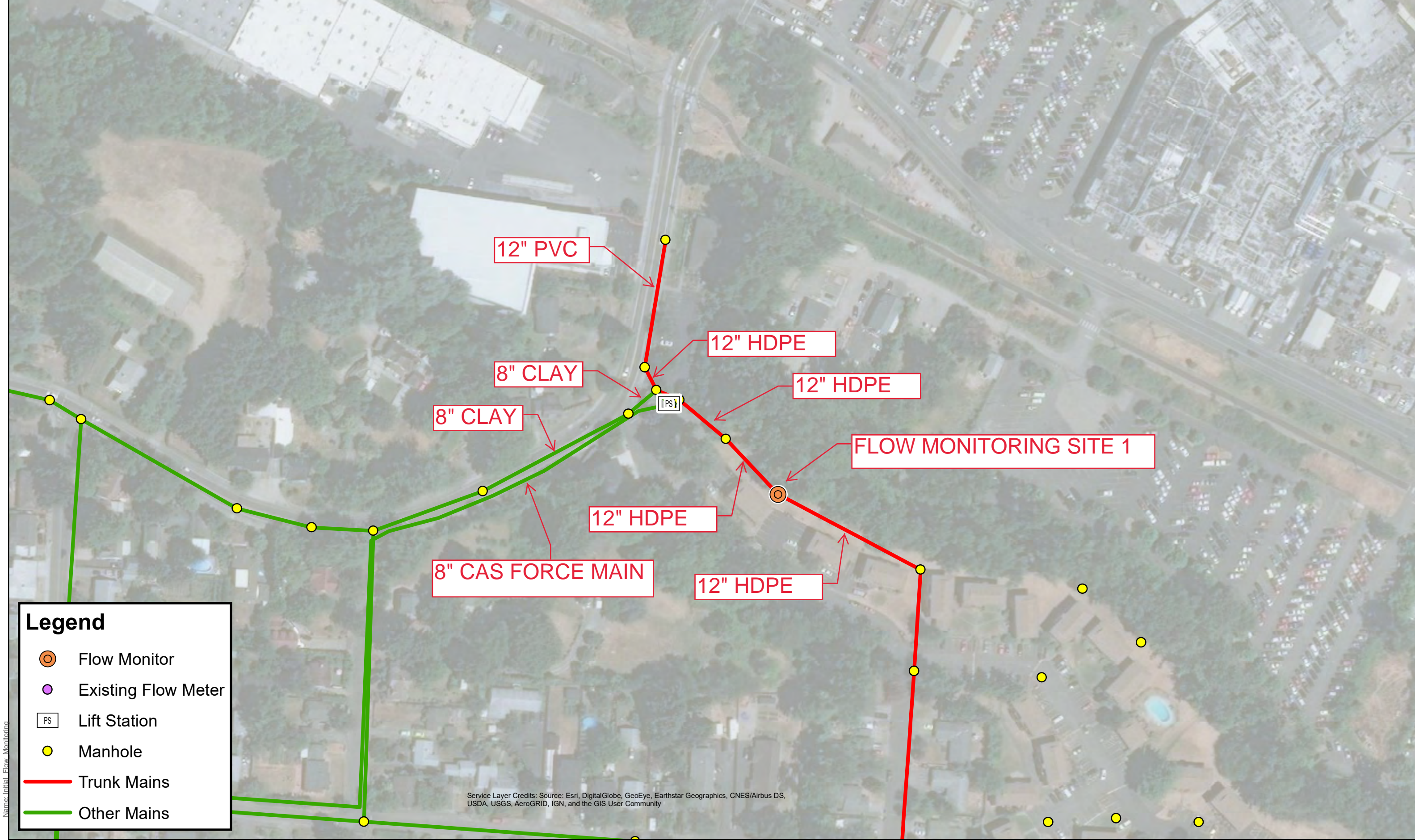
City of Milwaukee  
Sewer System

















**Legend**

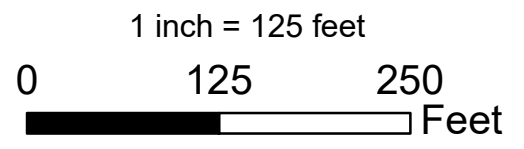
-  Flow Monitor
-  Existing Flow Meter
-  Lift Station
-  Manhole
-  Trunk Mains
-  Other Mains

Service Layer Credits: Source: Esri, DigitalGlobe, GeoEye, Earthstar Geographics, CNES/Airbus DS, USDA, USGS, AeroGRID, IGN, and the GIS User Community

Date: 9/9/2019



City of Milwaukee  
Sewer System















**Legend**

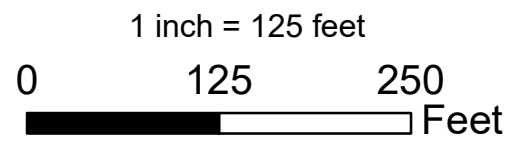
-  Flow Monitor
-  Existing Flow Meter
-  Lift Station
-  Manhole
-  Trunk Mains
-  Other Mains

Service Layer Credits: Source: Esri, DigitalGlobe, GeoEye, Earthstar Geographics, CNES/Airbus DS, USDA, USGS, AeroGRID, IGN, and the GIS User Community

Date: 9/9/2019



City of Milwaukee  
Sewer System















**Legend**

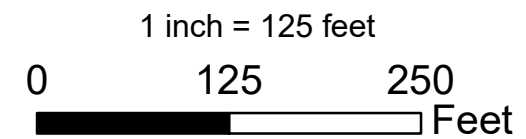
-  Flow Monitor
-  Existing Flow Meter
-  Lift Station
-  Manhole
-  Trunk Mains
-  Other Mains

Service Layer Credits: Source: Esri, DigitalGlobe, GeoEye, Earthstar Geographics, CNES/Airbus DS, USDA, USGS, AeroGRID, IGN, and the GIS User Community

Name: Initial Flow Monitoring  
Date: 9/9/2019



City of Milwaukee  
Sewer System















**Legend**

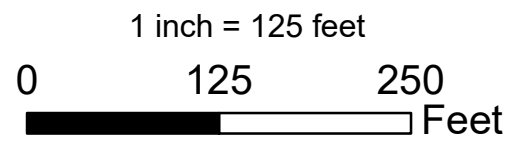
-  Flow Monitor
-  Existing Flow Meter
-  Lift Station
-  Manhole
-  Trunk Mains
-  Other Mains

Service Layer Credits: Source: Esri, DigitalGlobe, GeoEye, Earthstar Geographics, CNES/Airbus DS, USDA, USGS, AeroGRID, IGN, and the GIS User Community

Date: 9/9/2019



City of Milwaukee  
Sewer System









## 9 Appendix B - Flow Monitoring Sites





## Site Details Sheet

**CLIENT MONITORING #:** U026A  
**NAME:** Milwaukie OR TFM

**SFE PROJECT #:** U026A  
**SFE SITE #:** 1

### Project Specific Information

**Client Name:** City of Wilwaukie Public Works  
**End User Name:** City of Wilwaukie Public Works  
**Project Name:** Sanitary Sewer Flow Monitoring  
**Client Contact:** Scott Duren 503-419-6336  
**Field Contact:** Scott Duren 503-419-6336  
**SFE PM Contact:** Dylan Carvin  
**Site Maintenance:** as required

### Site Equipment

<b>Install / Removal Date:</b>	<u>May 1 19</u>	<u>June 4 19</u>
<b>Meter Make &amp; Model:</b>	<u>ISCO 2150</u>	
<b>Meter I.D. - #1 and #2</b>	<u>208H01081</u>	<u>na</u>
<b>Wireless I.D # / Cell #:</b>	<u>216M01654</u>	<u>na</u>
<b>Level / Velocity Type:</b>	<u>Pressure Probe</u>	<u>AV Sensor</u>
<b>Sensor Mounting:</b>	<u>Compression</u>	
<b>Primary Device:</b>	<u>Area Velocity</u>	
<b>Logging Rate / Call out:</b>	<u>5 minute</u>	<u>24hr</u>

### Site Location Information

**Client Site #:** 1  
**Address (Location):** 4517 SE Brookside Dr  
**City, Province:** Milwaukie, OR  
**GPS (North - West ):** 45.460111 122.616235  
**Landmarks:** na  
**Traffic Control Req's:** none  
**Additional Information:** na

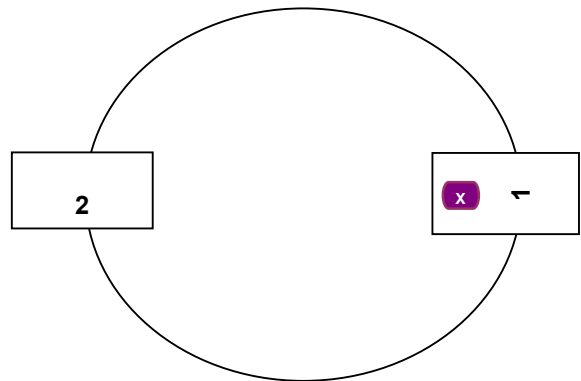
### Site Profile

**Invert Distance (in):** 112.5 **Access:** yes  
**Overall Site Condition:** good  
**Pipe Size #1** 12 **#2** 12  
**(in): #3** na **#4** na  
**Location of Sensor (which pipe?):** x = 1  
**Overall Pipe Condition:** good  
**Additional Information:** na

### Map



### Site Setup



### Additional Notes

- 
- 
-



## Site Pictures

CLIENT MONITORING #: U026A  
NAME: Milwaukie OR TFM

SFE PROJECT #: U026A  
SFE SITE #: 1



### Notes

- 1 location
- 2 after install
- 3

- 4 before install
- 5 after install
- 6



# Install Sheet

CLIENT FLOW MONITORING #: U026A  
NAME: Milwaukie OR TFM

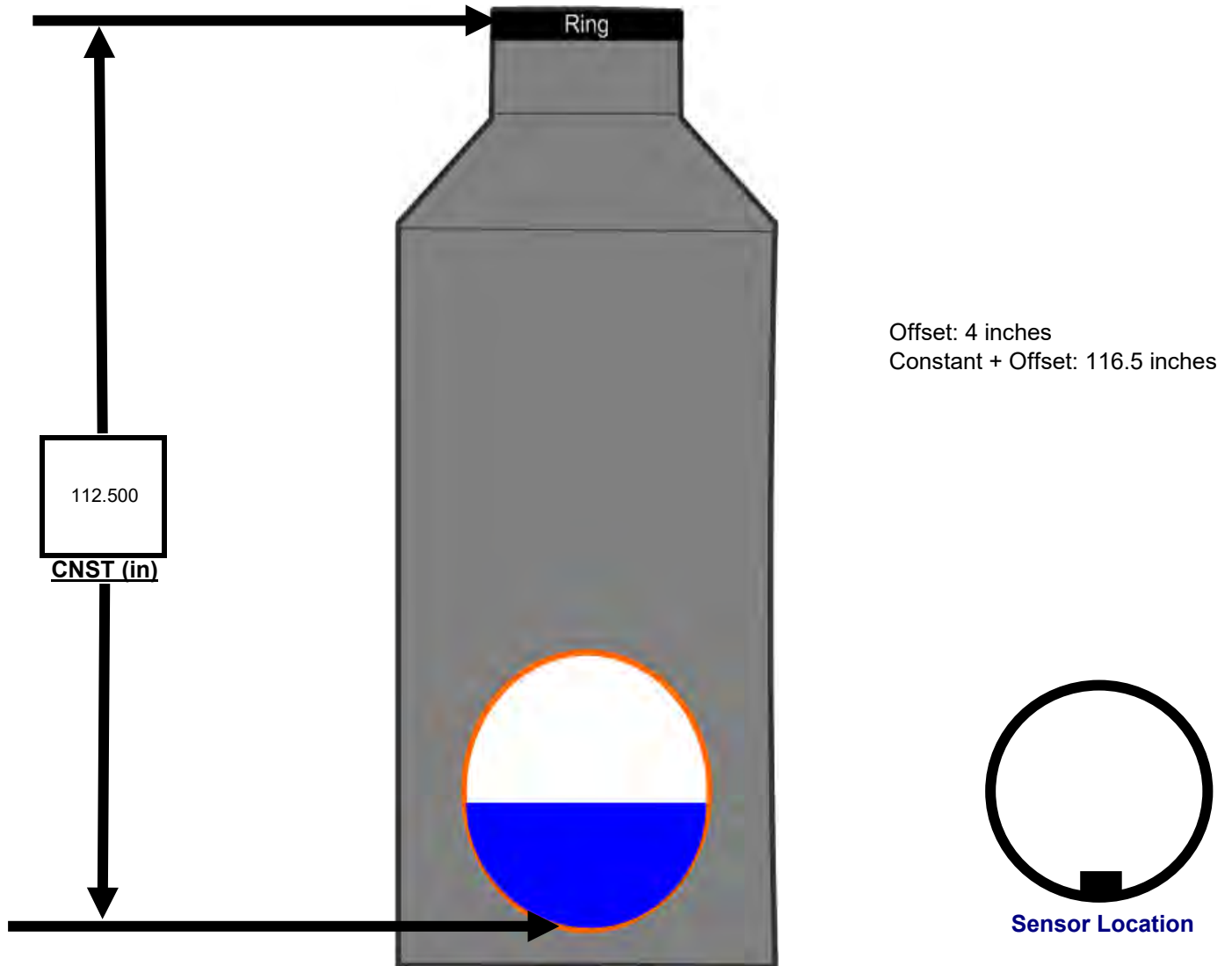
SFE PROJECT #: U026A  
SFE SITE #: 1  
Technician 1: Dylan Carvin  
Technician 2: Jason Rowley

## Meter Depth vs.. Field Depth Calibration / Verification

Reading Number	Date (m/d/yyyy)	Time (hh:mm)	Field Meas (in)	Meter Depth (in)	Comments (Zero Meter Level before Installation)
Initial	5-01-19	10:00	6.3	6.1	Depth offset of 4" included, LA to 6.25
1		(PST)	6.3	6.3	Installed AV
2			6.0	6.1	Installed Cell Module
3			6.0	5.9	Pipe Diameter = 12"
Average			6.1	6.1	Installed in the inlet pipe

\* Three Continuous Measurements Within 0.5 inch

\* Average Meter vs (WL1 and WL2) Within 5%







# Final Check-off Sheet

**CLIENT FLOW MONITORING #:** U026A  
**NAME:** Milwaukie OR TFM  
**Date / Time:** 01-May-19 1148 PST

**SFE PROJECT #:** U026A  
**SFE SITE #:** 1  
 Technician 1: Dylan Carvin  
 Technician 2: Jason Rowley

## Flow Meter Information

Meter Make & Model:	<u>ISCO 2150</u>	Logging Rate/Call Out:	<u>5 minute</u>   <u>24hr</u>
Meter I.D. #:	<u>208H01081</u>   <u>na</u>	Flow Units:	<u>cfs</u>
Wireless I.D. / Cell #:	<u>216M01654</u>   <u>na</u>	Velocity Units:	<u>ft/s</u>
Level / Velocity Type:	<u>Pressure Probe</u>   <u>AV Sensor</u>	Depth Units:	<u>in</u>
Primary Device:	<u>Area Velocity</u>	Surcharge Meter (Y/N):	<u>Y</u>
Battery Old / New	<u>12.8V</u>		

## Site Physical Information

Silt Level:	<u>0</u>	Weather:	<u>Sunny 60F</u>
Slope:	<u>N/A</u>	Weir Size:	<u>na</u>
Uniform Flow (Y/N)	<u>Yes</u>	Depth Only(DO)	
Debris in Flow (Y/N):	<u>Yes (sanitary)</u>	or Look up Table(LT)	<u>AV meter</u>
Pipe Material:	<u>Concrete</u>	Comments	<u>na</u>

## Check Off List

	Yes	No
Time Set:	<input checked="" type="checkbox"/>	<input type="checkbox"/>
Depth Calibrated:	<input checked="" type="checkbox"/>	<input type="checkbox"/>
Velocity Profile:	<input checked="" type="checkbox"/>	<input type="checkbox"/>
Download Data:	<input checked="" type="checkbox"/>	<input type="checkbox"/>
Wireless:	<input checked="" type="checkbox"/>	<input type="checkbox"/>
Meter Running:	<input checked="" type="checkbox"/>	<input type="checkbox"/>
Pipe Size Verified:	<input checked="" type="checkbox"/>	<input type="checkbox"/>
Photograph Taken:	<input checked="" type="checkbox"/>	<input type="checkbox"/>
Site Cleaned:	<input type="checkbox"/>	<input checked="" type="checkbox"/>
Site Secured:	<input checked="" type="checkbox"/>	<input type="checkbox"/>



## Site Details Sheet

**CLIENT MONITORING #:** U026A  
**NAME:** Milwaukie OR TFM

**SFE PROJECT #:** U026A  
**SFE SITE #:** 2

### Project Specific Information

**Client Name:** City of Wilwaulkie Public Works  
**End User Name:** City of Wilwaulkie Public Works  
**Project Name:** Sanitary Sewer Flow Monitoring  
**Client Contact:** Scott Duren 503-419-6336  
**Field Contact:** Scott Duren 503-419-6336  
**SFE PM Contact:** Dylan Carvin  
**Site Maintenance:** as required

### Site Equipment

<b>Install / Removal Date:</b>	<u>May 1 2019</u>	<u>June 4 2019</u>
<b>Meter Make &amp; Model:</b>	<u>ISCO 2150</u>	
<b>Meter I.D. - #1 and #2</b>	<u>206M01425</u>	<u>na</u>
<b>Wireless I.D # / Cell #:</b>	<u>215E02560</u>	<u>na</u>
<b>Level / Velocity Type:</b>	<u>Pressure Probe</u>	<u>AV Sensor</u>
<b>Sensor Mounting:</b>	<u>Hilti Band</u>	
<b>Primary Device:</b>	<u>Area Velocity</u>	
<b>Logging Rate / Call out:</b>	<u>5 minute</u>	<u>24hr</u>

### Site Location Information

**Client Site #:** 2  
**Address (Location):** Near 1906 SE Monroe St  
**City, Province:** Milwaukie, OR  
**GPS (North - West ):** 45.44364    122.64322  
**Landmarks:** n/a  
**Traffic Control Req's:** no traffic  
**Additional Information:** n/a

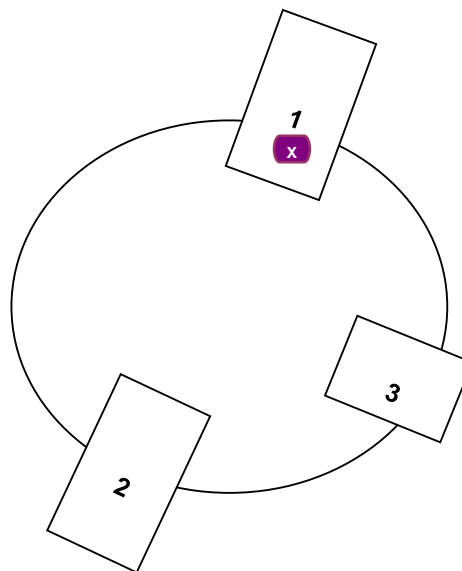
### Site Profile

**Invert Distance (in):** 167    **Access:** yes  
**Overall Site Condition:** good  
**Pipe Size #1** 24    **#2** 24  
**(in): #3** 10 (DC'd)    **#4** na  
**Location of Sensor (which pipe?):** x = 1  
**Overall Pipe Condition:** good  
**Additional Information:** na

### Map



### Site Setup



### Additional Notes

- 2 MH's downstream from original proposed site
- 
-



## Site Pictures

CLIENT MONITORING #: U026A  
NAME: Milwaukie OR TFM

SFE PROJECT #: U026A  
SFE SITE #: 2



### Notes

- 1 area
- 2 after install
- 3

- 4 before install
- 5 after install
- 6



# Install Sheet

CLIENT FLOW MONITORING #: U026A  
NAME: Milwaukie OR TFM

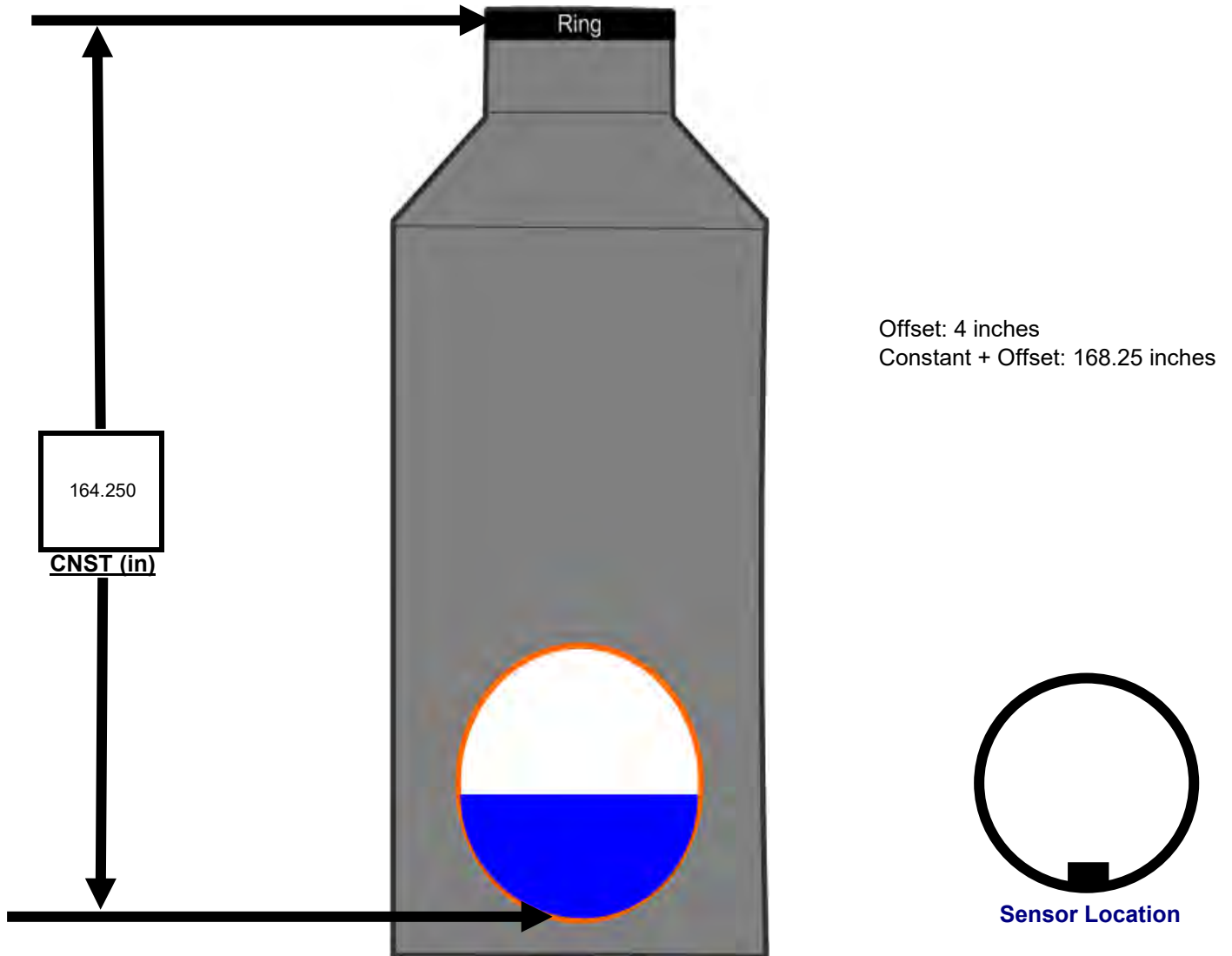
SFE PROJECT #: U026A  
SFE SITE #: 2  
Technician 1: Dylan Carvin  
Technician 2: Jason Rowley

## Meter Depth vs.. Field Depth Calibration / Verification

Reading Number	Date (m/d/yyyy)	Time (hh:mm)	Field Meas (in)	Meter Depth (in)	Comments (Zero Meter Level before Installation)
Initial	5-01-19	14:50	9.7	10.8	Depth offset of 4" included, LA to 9.7
1		(PST)	9.6	9.5	Installed AV
2			9.8	9.8	Installed Cell Module
3			10.0	10.0	Pipe Diameter = 24"
Average			9.8	9.8	Installed in the inlet pipe

\* Three Continuous Measurements Within 0.5 inch

\* Average Meter vs (WL1 and WL2) Within 5%







# Final Check-off Sheet

**CLIENT FLOW MONITORING #:** U026A  
**NAME:** Milwaukie OR TFM  
**Date / Time:** 01-May-19 1510 PST

**SFE PROJECT #:** U026A  
**SFE SITE #:** 2  
 Technician 1: Dylan Carvin  
 Technician 2: Jason Rowley

## Flow Meter Information

Meter Make & Model:	<u>ISCO 2150</u>	Logging Rate/Call Out:	<u>5 minute</u>   <u>24hr</u>
Meter I.D. #:	<u>206M01425</u>   <u>na</u>	Flow Units:	<u>cfs</u>
Wireless I.D. / Cell #:	<u>215E02560</u>   <u>na</u>	Velocity Units:	<u>ft/s</u>
Level / Velocity Type:	<u>Pressure Probe</u>   <u>AV Sensor</u>	Depth Units:	<u>in</u>
Primary Device:	<u>Area Velocity</u>	Surcharge Meter (Y/N):	<u>Y</u>
Battery Old / New	<u>12.8V</u>		

## Site Physical Information

Silt Level:	<u>0</u>	Weather:	<u>Sunny 60F</u>
Slope:	<u>N/A</u>	Weir Size:	<u>na</u>
Uniform Flow (Y/N)	<u>Yes</u>	Depth Only(DO)	
Debris in Flow (Y/N):	<u>Yes (sanitary)</u>	or Look up Table(LT)	<u>AV meter</u>
Pipe Material:	<u>Concrete</u>	Comments	<u>na</u>

## Check Off List

	Yes	No
Time Set:	x	
Depth Calibrated:	x	
Velocity Profile:	x	
Download Data:	x	
Wireless:	x	
Meter Running:	x	
Pipe Size Verified:	x	
Photograph Taken:	x	
Site Cleaned:		x
Site Secured:	x	



## Site Details Sheet

**CLIENT MONITORING #:** U026A  
**NAME:** Milwaukie OR TFM

**SFE PROJECT #:** U026A  
**SFE SITE #:** 3

### Project Specific Information

**Client Name:** City of Wilwaukie Public Works  
**End User Name:** City of Wilwaukie Public Works  
**Project Name:** Sanitary Sewer Flow Monitoring  
**Client Contact:** Scott Duren 503-419-6336  
**Field Contact:** Scott Duren 503-419-6336  
**SFE PM Contact:** Dylan Carvin  
**Site Maintenance:** as required

### Site Equipment

<b>Install / Removal Date:</b>	<u>May 1 2019</u>	<u>June 4 2019</u>
<b>Meter Make &amp; Model:</b>	<u>ISCO 2150</u>	
<b>Meter I.D. - #1 and #2</b>	<u>207H01748</u>	<u>na</u>
<b>Wireless I.D # / Cell #:</b>	<u>215T02901</u>	<u>na</u>
<b>Level / Velocity Type:</b>	<u>Pressure Probe</u>	<u>AV Sensor</u>
<b>Sensor Mounting:</b>	<u>Hilti Band</u>	
<b>Primary Device:</b>	<u>Area Velocity</u>	
<b>Logging Rate / Call out:</b>	<u>5 minute</u>	<u>24hr</u>

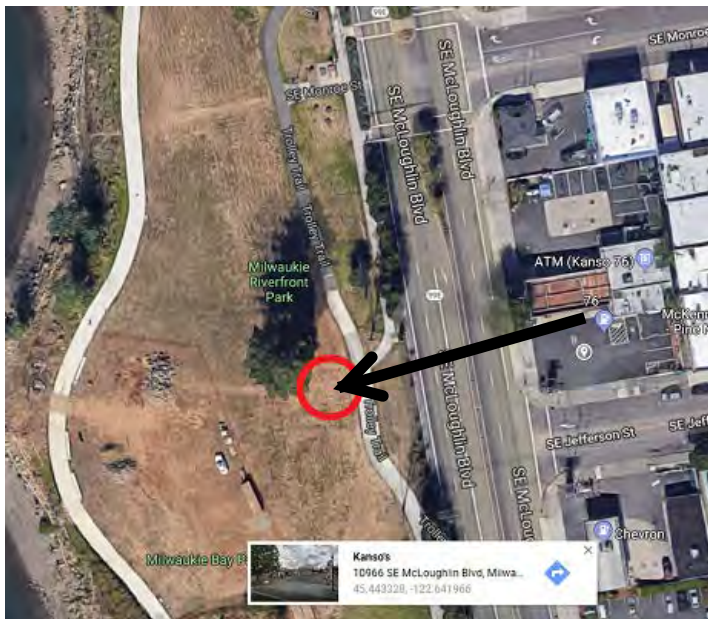
### Site Location Information

**Client Site #:** 3  
**Address (Location):** Near 10966 SE McLoughlin Blvd  
**City, Province:** Milwaukie, OR  
**GPS (North - West) :** 45.44328 122.64265  
**Landmarks:** n/a  
**Traffic Control Req's:** no traffic  
**Additional Information:** n/a

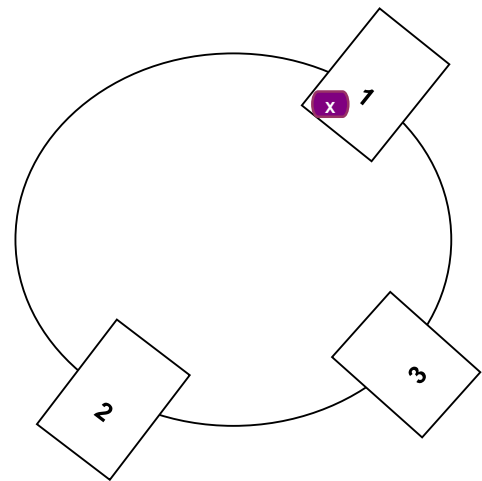
### Site Profile

**Invert Distance (in):** 148 **Access:** yes  
**Overall Site Condition:** good  
**Pipe Size #1** 21 **#2** 23  
**(in): #3** 10 (DC'd) **#4** na  
**Location of Sensor (which pipe?):** x = 1  
**Overall Pipe Condition:** good  
**Additional Information:** na

### Map



### Site Setup



### Additional Notes

- 1 MH upstream from originally proposed location
- 
- 
-



## Site Pictures

CLIENT MONITORING #: U026A  
NAME: Milwaukie OR TFM

SFE PROJECT #: U026A  
SFE SITE #: 3



### Notes

- 1 area
- 2 after install
- 3

- 4 before install
- 5 after install
- 6



# Install Sheet

CLIENT FLOW MONITORING #: U026A  
NAME: Milwaukie OR TFM

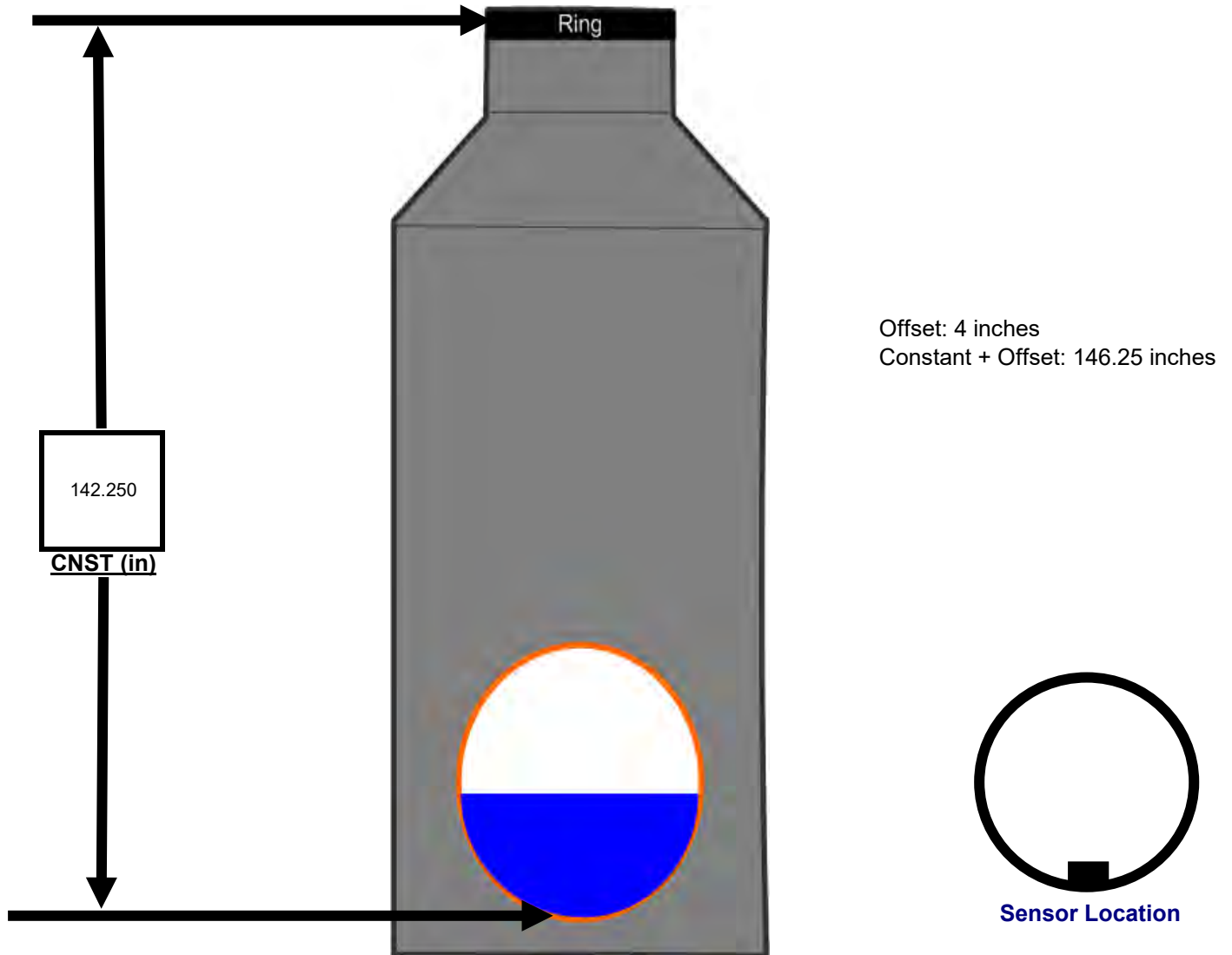
SFE PROJECT #: U026A  
SFE SITE #: 3  
Technician 1: Dylan Carvin  
Technician 2: Jason Rowley

## Meter Depth vs.. Field Depth Calibration / Verification

Reading Number	Date (m/d/yyyy)	Time (hh:mm)	Field Meas (in)	Meter Depth (in)	Comments (Zero Meter Level before Installation)
Initial	5-01-19	11:46	8.3	8.5	Depth offset of 4" included, LA to 8.25
1		(PST)	8.3	8.5	Installed AV
2			8.3	8.4	Installed Cell Module
3			8.3	8.7	Pipe Diameter = 21
Average			8.3	8.5	Installed in the inlet pipe

\* Three Continuous Measurements Within 0.5 inch

\* Average Meter vs (WL1 and WL2) Within 5%







**Final Check-off Sheet**

**CLIENT FLOW MONITORING #:** U026A  
**NAME:** Milwaukie OR TFM  
**Date / Time:** May 1 2019 1246 PST

**SFE PROJECT #:** U026A  
**SFE SITE #:** 3  
Technician 1: Dylan Carvin  
Technician 2: Jason Rowley

**Flow Meter Information**

Meter Make & Model:	<u>ISCO 2150</u>	Logging Rate/Call Out:	<u>5 minute</u>   <u>24hr</u>
Meter I.D. #:	<u>207H01748</u>   <u>na</u>	Flow Units:	<u>cfs</u>
Wireless I.D. / Cell #:	<u>215T02901</u>   <u>na</u>	Velocity Units:	<u>ft/s</u>
Level / Velocity Type:	<u>Pressure Probe</u>   <u>AV Sensor</u>	Depth Units:	<u>in</u>
Primary Device:	<u>Area Velocity</u>	Surcharge Meter (Y/N):	<u>Y</u>
Battery Old / New	<u>12.8V</u>		

**Site Physical Information**

Silt Level:	<u>0</u>	Weather:	<u>Sunny 60F</u>
Slope:	<u>N/A</u>	Weir Size:	<u>na</u>
Uniform Flow (Y/N)	<u>Yes</u>	Depth Only(DO)	
Debris in Flow (Y/N):	<u>Yes (sanitary)</u>	or Look up Table(LT)	<u>AV meter</u>
Pipe Material:	<u>Concrete</u>	Comments	<u>na</u>

**Check Off List**

	<b>Yes</b>	<b>No</b>
Time Set:	<input checked="" type="checkbox"/>	<input type="checkbox"/>
Depth Calibrated:	<input checked="" type="checkbox"/>	<input type="checkbox"/>
Velocity Profile:	<input checked="" type="checkbox"/>	<input type="checkbox"/>
Download Data:	<input checked="" type="checkbox"/>	<input type="checkbox"/>
Wireless:	<input checked="" type="checkbox"/>	<input type="checkbox"/>
Meter Running:	<input checked="" type="checkbox"/>	<input type="checkbox"/>
Pipe Size Verified:	<input checked="" type="checkbox"/>	<input type="checkbox"/>
Photograph Taken:	<input checked="" type="checkbox"/>	<input type="checkbox"/>
Site Cleaned:	<input type="checkbox"/>	<input checked="" type="checkbox"/>
Site Secured:	<input checked="" type="checkbox"/>	<input type="checkbox"/>



## Site Details Sheet

**CLIENT MONITORING #:** U026A  
**NAME:** Milwaukie OR TFM

**SFE PROJECT #:** U026A  
**SFE SITE #:** 4

### Project Specific Information

Client Name: City of Wilwaulkie Public Works  
 End User Name: City of Wilwaulkie Public Works  
 Project Name: Sanitary Sewer Flow Monitoring  
 Client Contact: Scott Duren 503-419-6336  
 Field Contact: Scott Duren 503-419-6336  
 SFE PM Contact: Dylan Carvin  
 Site Maintenance: as required

### Site Equipment

Install / Removal Date:	<u>May 2 2019</u>	<u>June 4 2019</u>
Meter Make & Model:	<u>ISCO 2150</u>	
Meter I.D. - #1 and #2	<u>XXXXXX814</u>	<u>na</u>
Wireless I.D # / Cell #:	<u>216J02894</u>	<u>na</u>
Level / Velocity Type:	<u>Pressure Probe</u>	<u>AV Sensor</u>
Sensor Mounting:	<u>Compression</u>	
Primary Device:	<u>Area Velocity</u>	
Logging Rate / Call out:	<u>5 minute</u>	<u>24hr</u>

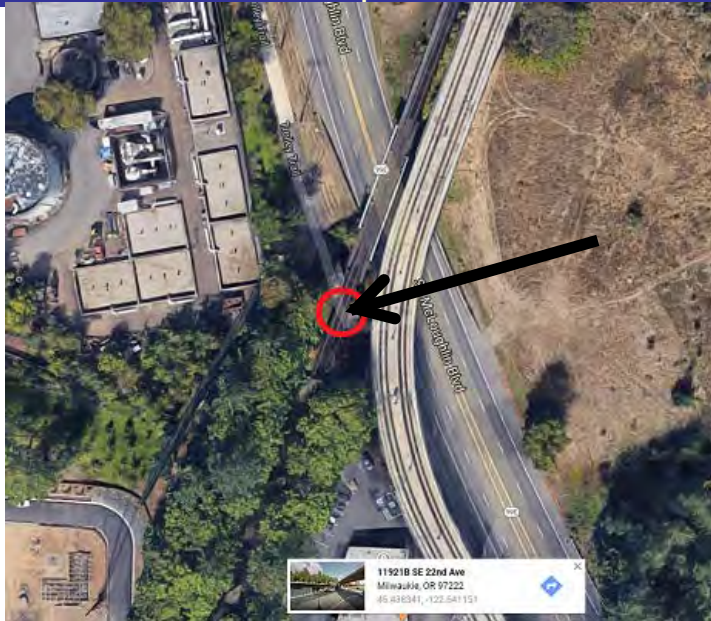
### Site Location Information

Client Site #: 4  
 Address (Location): Near 119218 SE 22<sup>nd</sup> Ave  
 City, Province: Milwaukie, OR  
 GPS (North - West): 45.43877 122.64128  
 Landmarks: n/a  
 Traffic Control Req's: local traffic  
 Additional Information: n/a

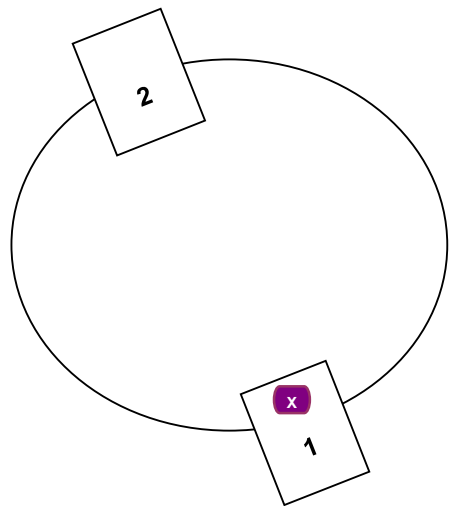
### Site Profile

Invert Distance (in): 129 Access: yes  
 Overall Site Condition: good  
 Pipe Size #1 15 #2 15  
 (in): #3 na #4 na  
 Location of Sensor (which pipe?): x = 1  
 Overall Pipe Condition: good  
 Additional Information: na

### Map



### Site Setup



### Additional Notes

- 
- 
-



## Site Pictures

CLIENT MONITORING #: U026A  
NAME: Milwaukie OR TFM

SFE PROJECT #: U026A  
SFE SITE #: 4



### Notes

- 1 area
- 2 after install
- 3

- 4 before install
- 5 after install
- 6



# Install Sheet

CLIENT FLOW MONITORING #: U026A  
NAME: Milwaukie OR TFM

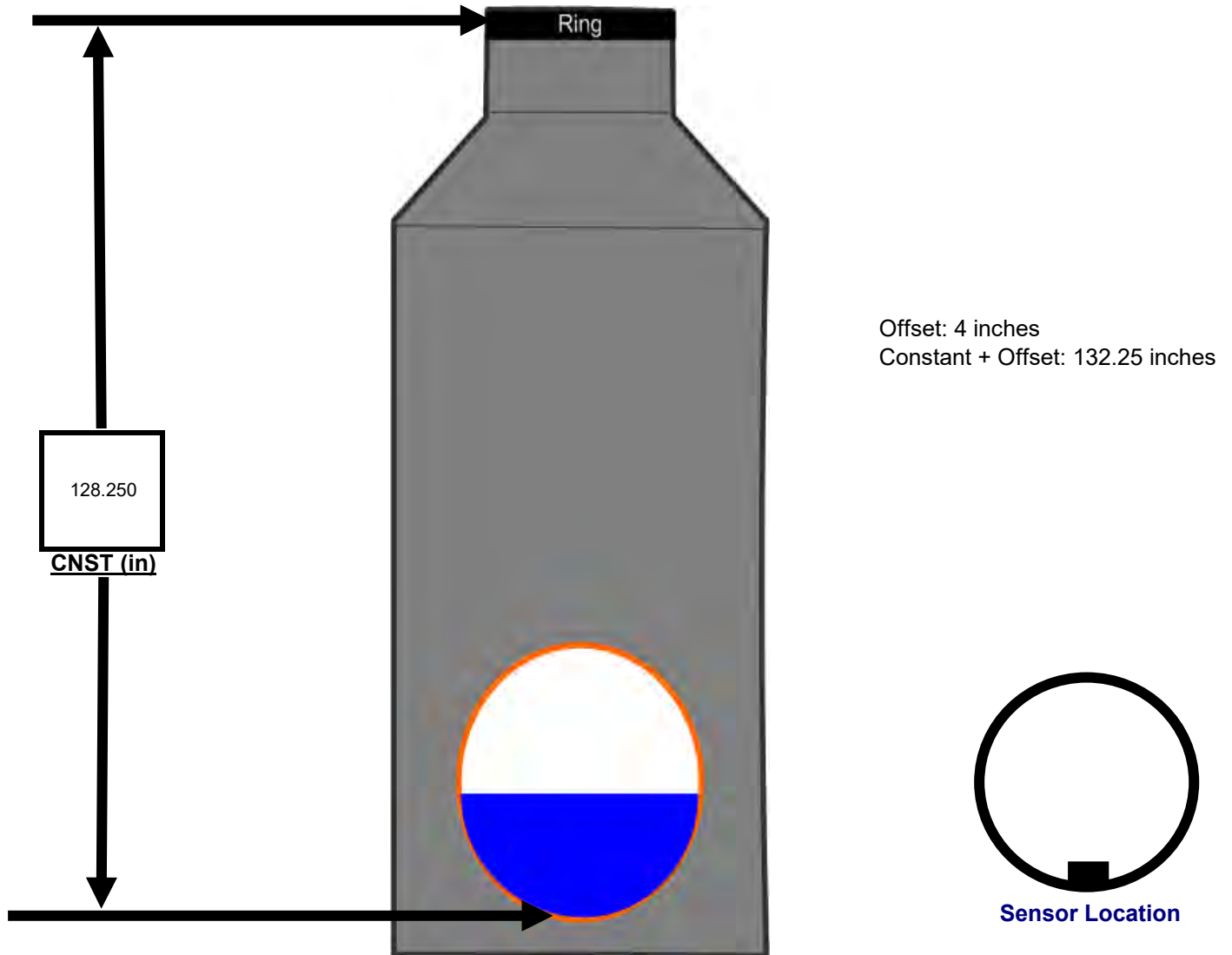
SFE PROJECT #: U026A  
SFE SITE #: 4  
Technician 1: Dylan Carvin  
Technician 2: Jason Rowley

## Meter Depth vs.. Field Depth Calibration / Verification

Reading Number	Date (m/d/yyyy)	Time (hh:mm)	Field Meas (in)	Meter Depth (in)	Comments (Zero Meter Level before Installation)
Initial	5-02-19	10:00	5.3	5.4	Depth offset of 4" included, LA to 5.3
1		(PST)	5.3	5.3	Installed AV
2			5.3	5.3	Installed Cell Module
3			5.3	5.3	Pipe Diameter = 15
Average			5.3	5.3	Installed in the inlet pipe

\* Three Continuous Measurements Within 0.5 inch

\* Average Meter vs (WL1 and WL2) Within 5%







# Final Check-off Sheet

**CLIENT FLOW MONITORING #:** U026A  
**NAME:** Milwaukie OR TFM  
**Date / Time:** 02-May-19 10:15 PST

**SFE PROJECT #:** U026A  
**SFE SITE #:** 4  
 Technician 1: Dylan Carvin  
 Technician 2: Jason Rowley

## Flow Meter Information

Meter Make & Model:	<u>ISCO 2150</u>	Logging Rate/Call Out:	<u>5 minute</u>   <u>24hr</u>
Meter I.D. #:	<u>XXXXXX814</u>   <u>na</u>	Flow Units:	<u>cfs</u>
Wireless I.D. / Cell #:	<u>216J02894</u>   <u>na</u>	Velocity Units:	<u>ft/s</u>
Level / Velocity Type:	<u>Pressure Probe</u>   <u>AV Sensor</u>	Depth Units:	<u>in</u>
Primary Device:	<u>Area Velocity</u>	Surcharge Meter (Y/N):	<u>Y</u>
Battery Old / New	<u>12.8V</u>		

## Site Physical Information

Silt Level:	<u>0</u>	Weather:	<u>Sunny 60F</u>
Slope:	<u>N/A</u>	Weir Size:	<u>na</u>
Uniform Flow (Y/N)	<u>Yes</u>	Depth Only(DO)	
Debris in Flow (Y/N):	<u>Yes (sanitary)</u>	or Look up Table(LT)	<u>AV meter</u>
Pipe Material:	<u>Concrete</u>	Comments	<u>na</u>

## Check Off List

	Yes	No
Time Set:	<input checked="" type="checkbox"/>	<input type="checkbox"/>
Depth Calibrated:	<input checked="" type="checkbox"/>	<input type="checkbox"/>
Velocity Profile:	<input checked="" type="checkbox"/>	<input type="checkbox"/>
Download Data:	<input checked="" type="checkbox"/>	<input type="checkbox"/>
Wireless:	<input checked="" type="checkbox"/>	<input type="checkbox"/>
Meter Running:	<input checked="" type="checkbox"/>	<input type="checkbox"/>
Pipe Size Verified:	<input checked="" type="checkbox"/>	<input type="checkbox"/>
Photograph Taken:	<input checked="" type="checkbox"/>	<input type="checkbox"/>
Site Cleaned:	<input type="checkbox"/>	<input checked="" type="checkbox"/>
Site Secured:	<input checked="" type="checkbox"/>	<input type="checkbox"/>



## Site Details Sheet

**CLIENT MONITORING #:** U026A  
**NAME:** Milwaukie OR TFM

**SFE PROJECT #:** U026A  
**SFE SITE #:** 5

### Project Specific Information

**Client Name:** City of Wilwaulkie Public Works  
**End User Name:** City of Wilwaulkie Public Works  
**Project Name:** Sanitary Sewer Flow Monitoring  
**Client Contact:** Scott Duren 503-419-6336  
**Field Contact:** Scott Duren 503-419-6336  
**SFE PM Contact:** Dylan Carvin  
**Site Maintenance:** as required

### Site Equipment

<b>Install / Removal Date:</b>	<u>May 2 2019</u>	<u>June 4 2019</u>
<b>Meter Make &amp; Model:</b>	<u>ISCO 2150</u>	
<b>Meter I.D. - #1 and #2</b>	<u>211C00869</u>	<u>na</u>
<b>Wireless I.D # / Cell #:</b>	<u>215J02894</u>	<u>na</u>
<b>Level / Velocity Type:</b>	<u>Pressure Probe</u>	<u>AV Sensor</u>
<b>Sensor Mounting:</b>	<u>Hilti Band</u>	
<b>Primary Device:</b>	<u>Area Velocity</u>	
<b>Logging Rate / Call out:</b>	<u>5 minute</u>	<u>24hr</u>

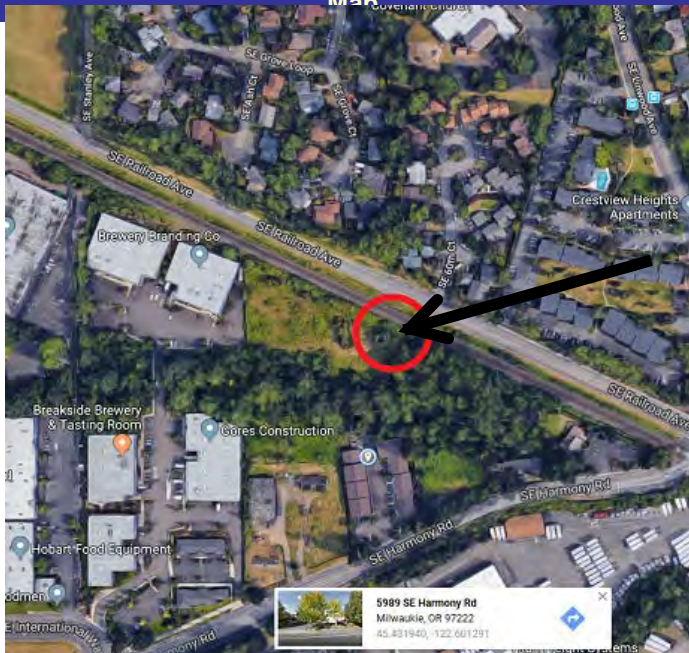
### Site Location Information

**Client Site #:** 5  
**Address (Location):** Near 5989 SE Harmony Rd  
**City, Province:** Milwaukie, OR  
**GPS (North - West ):** 45.43268 122.60102  
**Landmarks:** n/a  
**Traffic Control Req's:** local traffic  
**Additional Information:** n/a

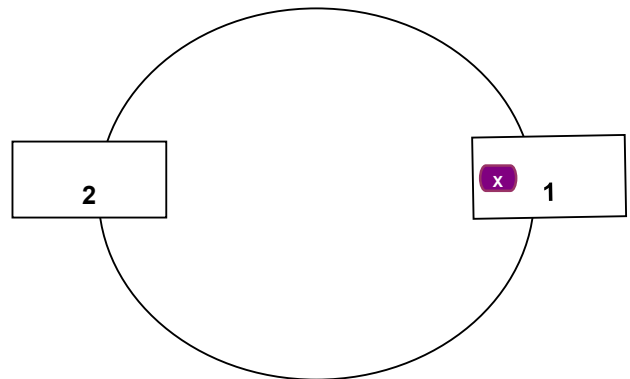
### Site Profile

**Invert Distance (in):** 267 **Access:** yes  
**Overall Site Condition:** good  
**Pipe Size #1** 14 **#2** 14  
**(in): #3** na **#4** na  
**Location of Sensor (which pipe?):** x = 1  
**Overall Pipe Condition:** good  
**Additional Information:** na

### Map



### Site Setup



### Additional Notes

- 
- 
-



## Site Pictures

CLIENT MONITORING #: U026A  
NAME: Milwaukie OR TFM

SFE PROJECT #: U026A  
SFE SITE #: 5



### Notes

- 1 area
- 2 after install
- 3

- 4 before install
- 5 after install
- 6



# Install Sheet

CLIENT FLOW MONITORING #: U026A  
NAME: Milwaukie OR TFM

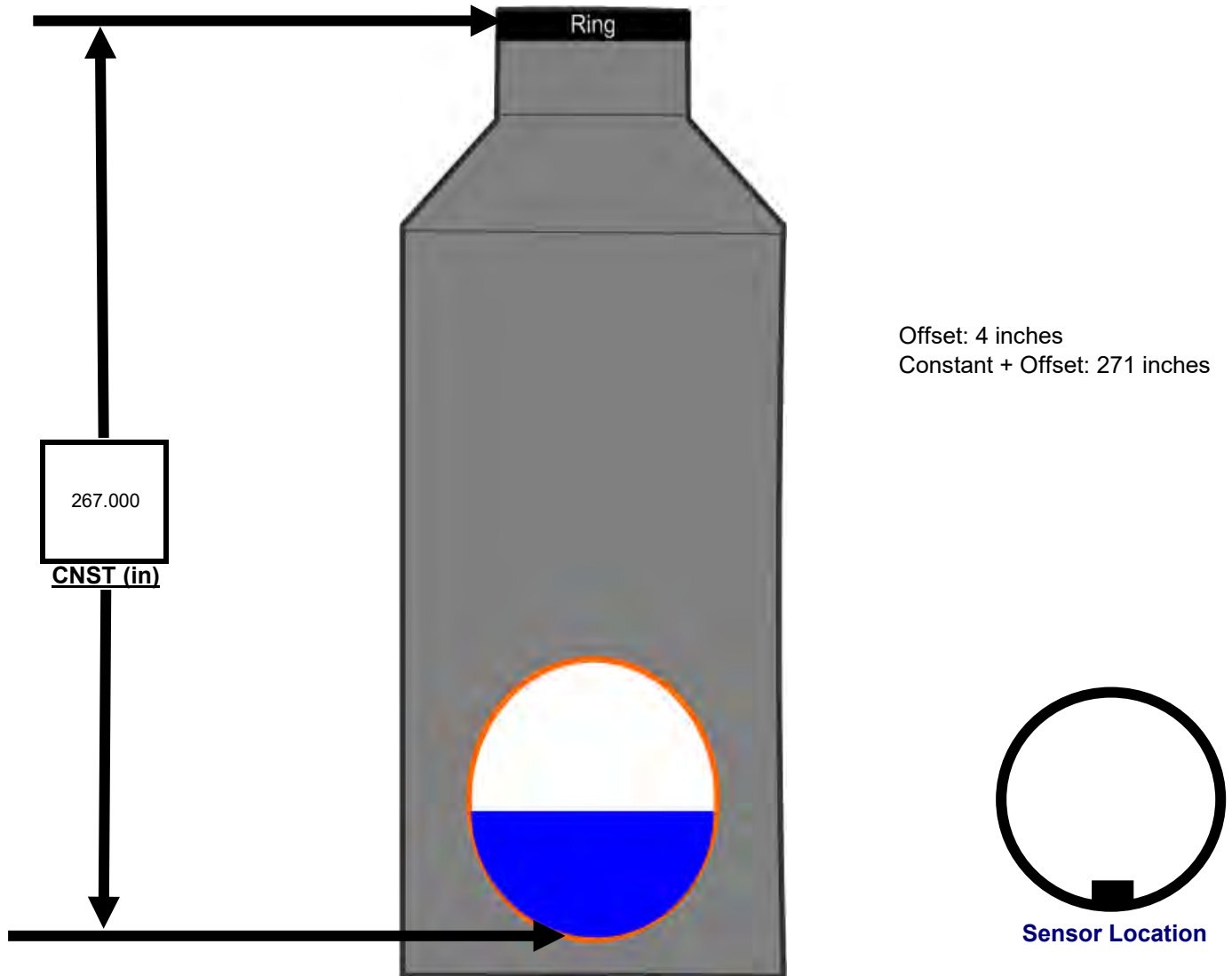
SFE PROJECT #: U026A  
SFE SITE #: 5  
Technician 1: Dylan Carvin  
Technician 2: Jason Rowley

## Meter Depth vs.. Field Depth Calibration / Verification

Reading Number	Date (m/d/yyyy)	Time (hh:mm)	Field Meas (in)	Meter Depth (in)	Comments (Zero Meter Level before Installation)
Initial	5-02-19	13:11	7.8	7.2	Depth offset of 4" included, LA to 7.8
1		(PST)	7.8	7.6	Installed AV
2			7.8	7.6	Installed Cell Module
3			7.8	7.6	Pipe Diameter = 14
Average			7.8	7.6	Installed in the inlet pipe

\* Three Continuous Measurements Within 0.5 inch

\* Average Meter vs (WL1 and WL2) Within 5%







# Final Check-off Sheet

CLIENT FLOW MONITORING #: U026A  
NAME: Milwaukie OR TFM  
Date / Time: May 2 2019 1311 PST

SFE PROJECT #: U026A  
SFE SITE #: 5  
Technician 1: Dylan Carvin  
Technician 2: Jason Rowley

## Flow Meter Information

Meter Make & Model:	<u>ISCO 2150</u>		Logging Rate/Call Out:	<u>5 minute</u>	<u>24hr</u>
Meter I.D. #:	<u>211C00869</u>	<u>na</u>	Flow Units:	<u>cfs</u>	
Wireless I.D. / Cell #:	<u>215J02894</u>	<u>na</u>	Velocity Units:	<u>ft/s</u>	
Level / Velocity Type:	<u>Pressure Probe</u>	<u>AV Sensor</u>	Depth Units:	<u>in</u>	
Primary Device:	<u>Area Velocity</u>		Surcharge Meter (Y/N):	<u>Y</u>	
Battery Old / New		<u>12.8V</u>			

## Site Physical Information

Silt Level:	<u>0</u>	Weather:	<u>Sunny 60F</u>
Slope:	<u>N/A</u>	Weir Size:	<u>na</u>
Uniform Flow (Y/N)	<u>Yes</u>	Depth Only(DO)	
Debris in Flow (Y/N):	<u>Yes (sanitary)</u>	or Look up Table(LT)	<u>AV meter</u>
Pipe Material:	<u>Concrete</u>	Comments	<u>na</u>

## Check Off List

	Yes	No
Time Set:	<input checked="" type="checkbox"/>	<input type="checkbox"/>
Depth Calibrated:	<input checked="" type="checkbox"/>	<input type="checkbox"/>
Velocity Profile:	<input checked="" type="checkbox"/>	<input type="checkbox"/>
Download Data:	<input checked="" type="checkbox"/>	<input type="checkbox"/>
Wireless:	<input checked="" type="checkbox"/>	<input type="checkbox"/>
Meter Running:	<input checked="" type="checkbox"/>	<input type="checkbox"/>
Pipe Size Verified:	<input checked="" type="checkbox"/>	<input type="checkbox"/>
Photograph Taken:	<input checked="" type="checkbox"/>	<input type="checkbox"/>
Site Cleaned:	<input type="checkbox"/>	<input checked="" type="checkbox"/>
Site Secured:	<input checked="" type="checkbox"/>	<input type="checkbox"/>



## Site Details Sheet

**CLIENT MONITORING #:** U026A  
**NAME:** Milwaukie OR TFM

**SFE PROJECT #:** U026A  
**SFE SITE #:** 6

### Project Specific Information

**Client Name:** City of Wilwaulkie Public Works  
**End User Name:** City of Wilwaulkie Public Works  
**Project Name:** Sanitary Sewer Flow Monitoring  
**Client Contact:** Scott Duren      503-419-6336  
**Field Contact:** Scott Duren      503-419-6336  
**SFE PM Contact:** Dylan Carvin  
**Site Maintenance:** as required

### Site Equipment

<b>Install / Removal Date:</b>	<u>May 3 2019</u>	<u>June 4 2019</u>
<b>Meter Make &amp; Model:</b>	<u>ISCO 2150</u>	
<b>Meter I.D. - #1 and #2</b>	<u>201H01487</u>	<u>na</u>
<b>Wireless I.D # / Cell #:</b>	<u>215F02688</u>	<u>na</u>
<b>Level / Velocity Type:</b>	<u>Pressure Probe</u>	<u>AV Sensor</u>
<b>Sensor Mounting:</b>	<u>Hilti Band</u>	
<b>Primary Device:</b>	<u>Area Velocity</u>	
<b>Logging Rate / Call out:</b>	<u>5 minute</u>	<u>24hr</u>

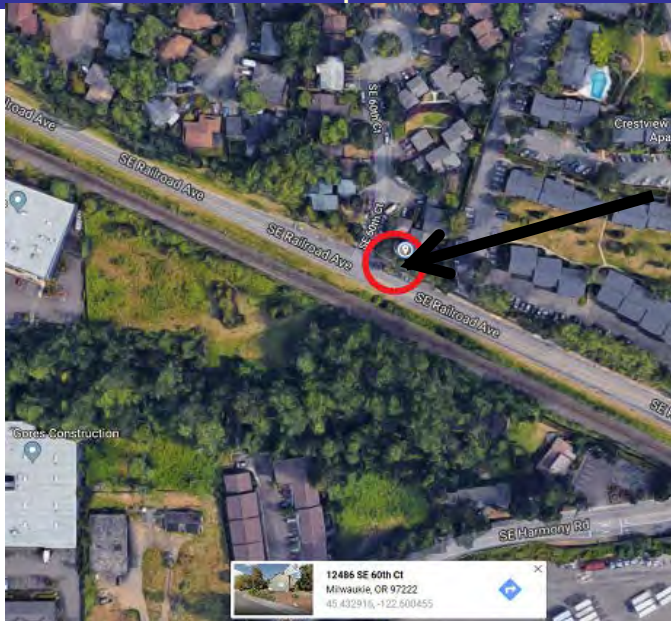
### Site Location Information

**Client Site #:** 6  
**Address (Location):** Near 12486 SE 60<sup>th</sup> Ct  
**City, Province:** Milwaukie, OR  
**GPS (North - West ):** 45.4328      122.60049  
**Landmarks:** n/a  
**Traffic Control Req's:** local traffic  
**Additional Information:** n/a

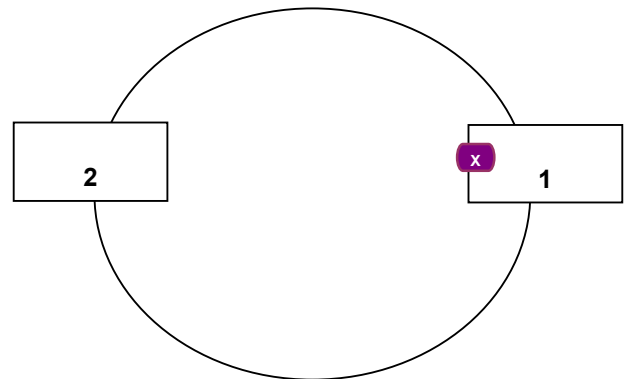
### Site Profile

**Invert Distance (in):** 119      **Access:** yes  
**Overall Site Condition:** good  
**Pipe Size #1** 15      **#2** 15  
**(in): #3** na      **#4** na  
**Location of Sensor (which pipe?):** x = 1  
**Overall Pipe Condition:** good  
**Additional Information:** na

### Map



### Site Setup



### Additional Notes

- 
- 
-



## Site Pictures

CLIENT MONITORING #: U026A  
NAME: Milwaukie OR TFM

SFE PROJECT #: U026A  
SFE SITE #: 6



### Notes

- 1 area
- 2 after install
- 3

- 4 before install
- 5 after install
- 6



# Install Sheet

CLIENT FLOW MONITORING #: U026A  
NAME: Milwaukie OR TFM

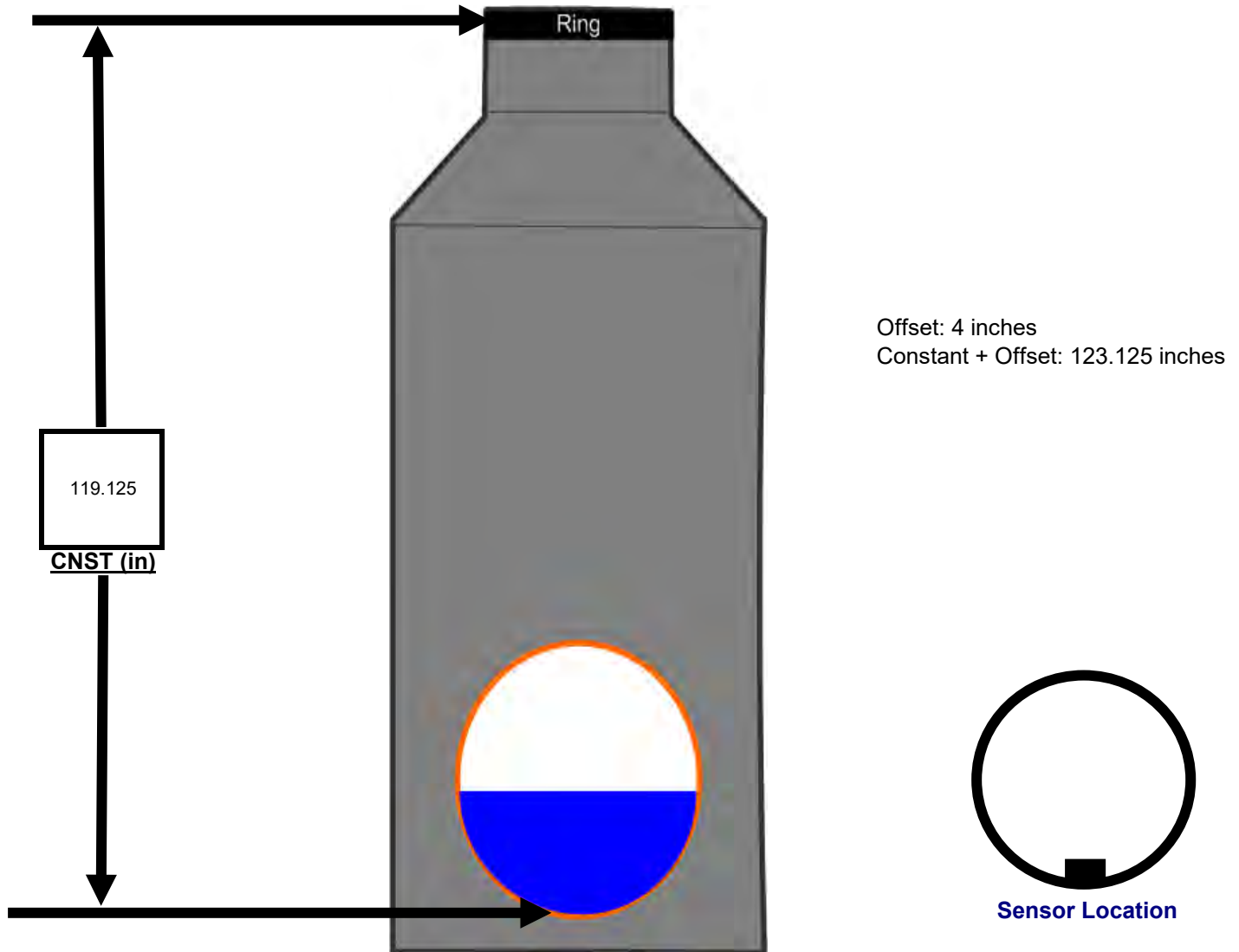
SFE PROJECT #: U026A  
SFE SITE #: 6  
Technician 1: Dylan Carvin  
Technician 2: Jason Rowley

## Meter Depth vs.. Field Depth Calibration / Verification

Reading Number	Date (m/d/yyyy)	Time (hh:mm)	Field Meas (in)	Meter Depth (in)	Comments (Zero Meter Level before Installation)
Initial	5-03-19	8:56	6.3	4.4	Depth offset of 4" included, LA to 6.25
1		(PST)	6.5	6.5	Installed AV
2			6.5	6.6	Installed Cell Module
3			6.5	6.7	Pipe Diameter = 15
Average			6.5	6.6	Installed in the inlet pipe

\* Three Continuous Measurements Within 0.5 inch

\* Average Meter vs (WL1 and WL2) Within 5%







# Final Check-off Sheet

**CLIENT FLOW MONITORING #:** U026A  
**NAME:** Milwaukie OR TFM  
**Date / Time:** 03-May-19 9:05 PST

**SFE PROJECT #:** U026A  
**SFE SITE #:** 6  
 Technician 1: Dylan Carvin  
 Technician 2: Jason Rowley

## Flow Meter Information

Meter Make & Model:	<u>ISCO 2150</u>	Logging Rate/Call Out:	<u>5 minute</u>   <u>24hr</u>
Meter I.D. #:	<u>201H01487</u>   <u>na</u>	Flow Units:	<u>cfs</u>
Wireless I.D. / Cell #:	<u>215F02688</u>   <u>na</u>	Velocity Units:	<u>ft/s</u>
Level / Velocity Type:	<u>Pressure Probe</u>   <u>AV Sensor</u>	Depth Units:	<u>in</u>
Primary Device:	<u>Area Velocity</u>	Surcharge Meter (Y/N):	<u>Y</u>
Battery Old / New	<u>12.8V</u>		

## Site Physical Information

Silt Level:	<u>0</u>	Weather:	<u>Sunny 60F</u>
Slope:	<u>N/A</u>	Weir Size:	<u>na</u>
Uniform Flow (Y/N)	<u>Yes</u>	Depth Only(DO)	
Debris in Flow (Y/N):	<u>Yes (sanitary)</u>	or Look up Table(LT)	<u>AV meter</u>
Pipe Material:	<u>Concrete</u>	Comments	<u>na</u>

## Check Off List

	Yes	No
Time Set:	x	
Depth Calibrated:	x	
Velocity Profile:	x	
Download Data:	x	
Wireless:	x	
Meter Running:	x	
Pipe Size Verified:	x	
Photograph Taken:	x	
Site Cleaned:		x
Site Secured:	x	



## Site Details Sheet

**CLIENT MONITORING #:** U026A  
**NAME:** Milwaulkie OR TFM

**SFE PROJECT #:** U026A  
**SFE SITE #:** RG1

### Project Specific Information

Client Name: City of Wilwaulkie Public Works  
 End User Name: City of Wilwaulkie Public Works  
 Project Name: Sanitary Sewer Flow Monitoring  
 Client Contact: Scott Duren      503-419-6336  
 Field Contact: Scott Duren      503-419-6336  
 SFE PM Contact: Dylan Carvin  
 Site Maintenance: as required

### Site Equipment

Install / Removal Date: May 3 2019 | June 4 2019  
 Meter Make & Model: ISCO IM  
 Meter I.D.: 208E01470 | 5 minute  
 Wireless Provider: KORE  
 SIM Card #: TBD  
 Tipping Bucket: other  
 Solar Panel: N/A  
 Logging Rate / Call out: 5 minute | 24hr

### Site Location Information

Client Site #: RG  
 Address (Location): 6101 SE Johnson Creek Blvd  
 City, Province: Milwaulkie, OR  
 GPS (North - West): 45.45737      122.60098  
 Landmarks: MPU storage yard  
 Traffic Control Req's: n/a  
 Additional Information: multiple possible locations

### Site Profile

Details: Wireless Access: yes  
 Overall Site Condition: good  
 #1 0.1 in      #2 N/A  
 Tips (in): #3 N/A      #4 N/A  
 Location of Equipment: = ground  
 Equipment Owner: SFE  
 Additional Information: N/A

### Map



### Site Setup

see photos next page

### Additional Notes

- 
- 
- 

- 
- 
-



## Site Pictures

CLIENT MONITORING #: U026A  
NAME: Milwaulkie OR TFM

SFE PROJECT #: U026A  
SFE SITE #: RG1



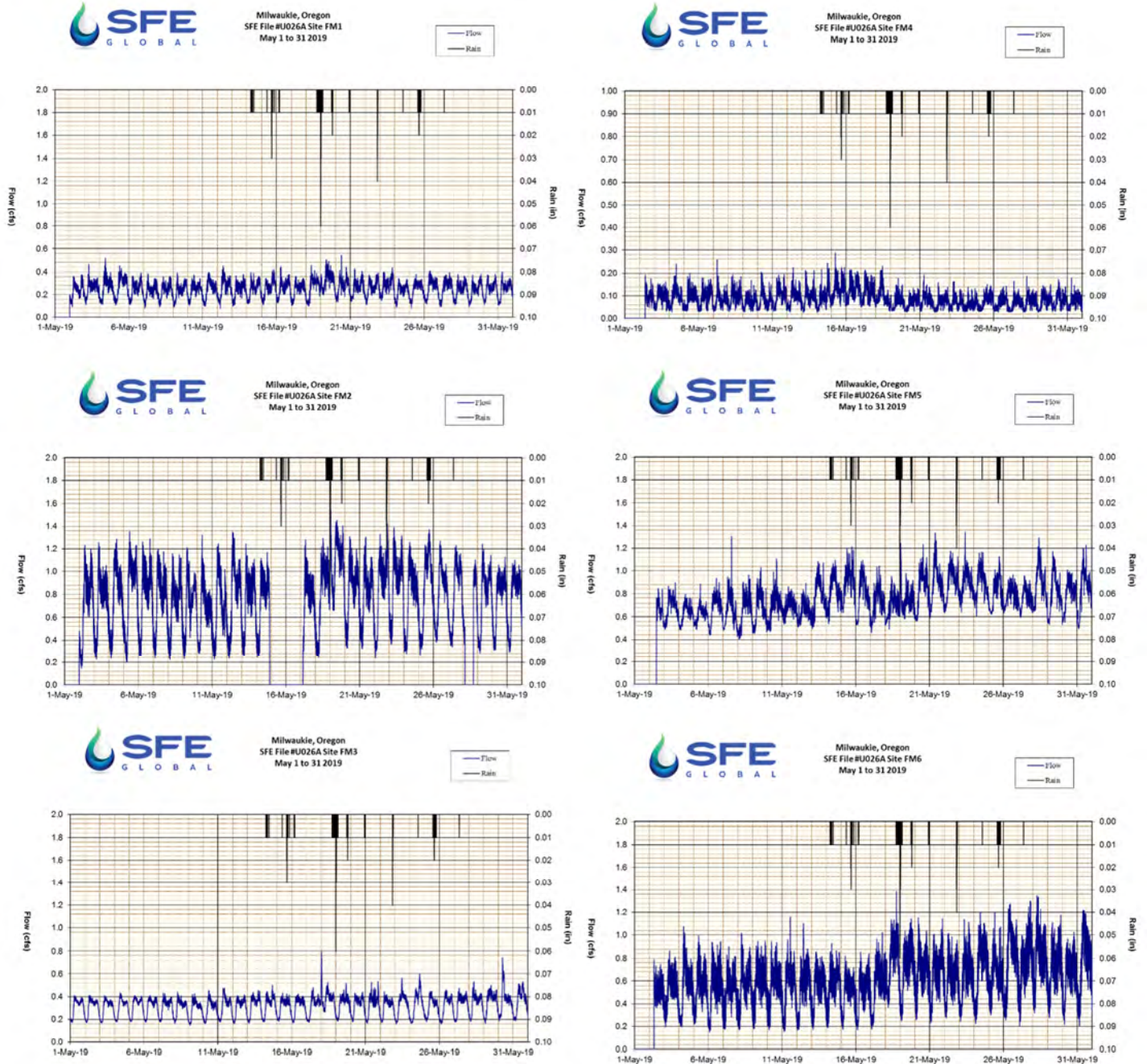
### Notes

- |   |   |
|---|---|
| 1 | 5 |
| 2 | 6 |
| 3 | 7 |
| 4 | 8 |



# 10 Appendix C - Flow Monitoring Results

## Initial Flow Monitoring



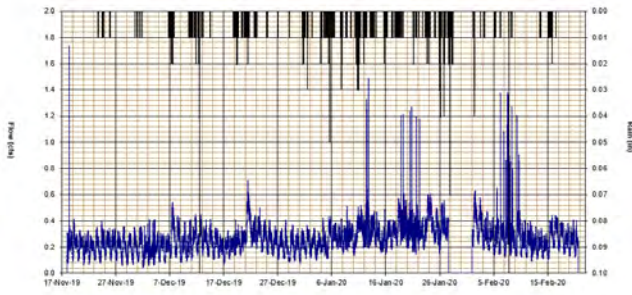


# Wet Weather Flow Monitoring



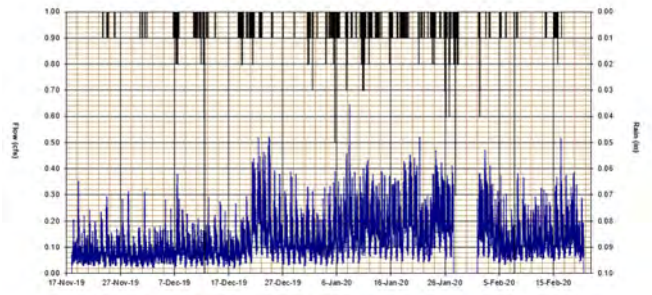
Milwaukie, Oregon  
SFE File #0026A Site FM2  
November 18, 2019 to February 20, 2020

Flow Rain



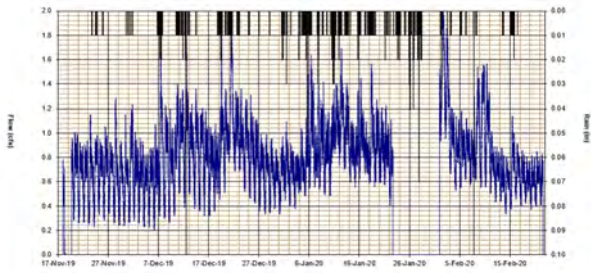
Milwaukie, Oregon  
SFE File #0026A Site FM4  
November 18, 2019 to February 20, 2020

Flow Rain



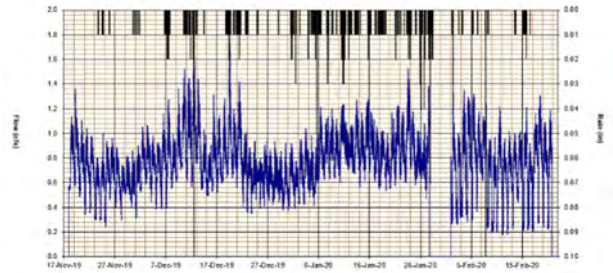
Milwaukie, Oregon  
SFE File #0026A Site FM2  
November 18, 2019 to February 20, 2020

Flow Rain



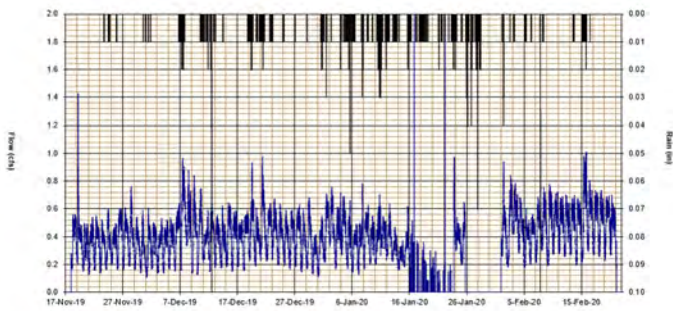
Milwaukie, Oregon  
SFE File #0026A Site FM5  
November 18, 2019 to February 20, 2020

Flow Rain



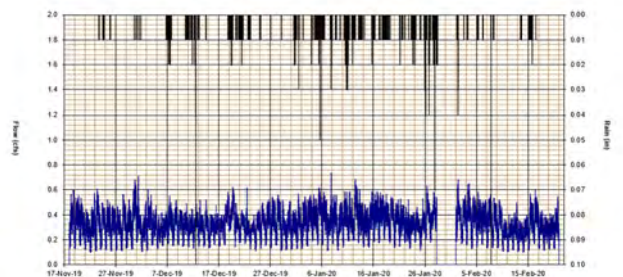
Milwaukie, Oregon  
SFE File #0026A Site FM3  
November 18, 2019 to February 20, 2020

Flow Rain



Milwaukie, Oregon  
SFE File #0026A Site FM6  
November 18, 2019 to February 20, 2020

Flow Rain



# Appendix F. NASSCO PACP Defect Scoring

The following tables identify the types of Grade 5 and Grade 4 PACP defects per NASSCO PACP Version 7. Please refer to the latest addition of NASSCO's Pipeline Assessment Certification Program manual for additional information on each type of defect, including sample photos.

Grade 5 Structural Defects	Grade 5 Operations and Maintenance Defects	
Hole Soil Visible	Deposits Attached Encrustation, greater than 30%	Obstruction Construction Debris, greater than 30%
Hole Void Visible	Deposits Attached Grease, greater than 30%	Obstacle/Obstruction Rocks, greater than 30%
Deformed Ridge, greater than 5%	Deposits Attached Ragging, greater than 30%	Obstacle/Obstruction Other Objects, greater than 30%
Deformed Flexible Bulging Round, greater than 10%	Deposits Attached Other, greater than 30%	Tap Factory Intruding, greater than 30%
Deformed Flexible Bulging Inverse Curvature	Deposits Settled Hard/Compacted, greater than 30%	Tap Break-In/Hammer Intruding, greater than 30%
Deformed Flexible Creasing	Deposits Settled Fine, greater than 30%	Tap Saddle Intruding, greater than 30%
Deformed Brick Bulging Round, greater than 5%	Deposits Settled Gravel, greater than 30%	Tap Rehabilitated Intruding, greater than 30%
Deformed Bulging Inverse Curvature	Obstruction Brick or Masonry, greater than 30%	Intruding Sealing Material Sealing Ring, greater than 30%
Collapse	Obstruction Pipe Material in Invert, greater than 30%	Intruding Seal Material Sealing Ring Hanging, greater than 30%
Surface Damage Reinforcement Projecting	Obstruction Intruding Through Wall	Intruding Seal Material Sealing Ring Broken, greater than 30%
Surface Damage Reinforcement Corroded	Obstruction Wedged in Joint, greater than 30%	Intruding Seal Material Sealing Loose, Poorly Fitting, greater than 30%
Surface Damage Missing Wall	Obstruction Through Connection, greater than 30%	Intruding Sealing Material Grout, greater than 30%
Dropped Invert (Brickwork only)	Obstruction External Pipe or Cable, greater than 30%	Intruding Sealing Material Other, greater than 30%
Miscellaneous Water Level Sag, greater than 75%	Obstruction Built into Structure, greater than 30%	

Grade 4 Structural Defects	Grade 4 Operations and Maintenance Defects	
Deformed Ridge, less than or equal to 5%	Deposits Attached Encrustation, greater than 20%, less than or equal to 30%	Tap Break-In/Hammer Intruding, greater than 20%, less than or equal to 30%
Deformed Flexible Bulging Round, greater than 5%, less than or equal to 10%	Deposits Attached Grease, greater than 20%, less than or equal to 30%	Tap Saddle Intruding, greater than 20%, less than or equal to 30%
Deformed Brick Bulging Round, less than or equal to 5%	Deposits Attached Ragging, greater than 20%, less than or equal to 30%	Tap Rehabilitated Intruding, greater than 20%, less than or equal to 30%
Joint Offset Large	Deposits Attached Other, greater than 20%, less than or equal to 30%	Intruding Sealing Material Sealing Ring, greater than 20%, less than or equal to 30%
Joint Offset Large Defective	Deposits Settled Hard/Compacted, greater than 20%, less than or equal to 30%	Intruding Seal Material Sealing Ring Hanging, greater than 20%, less than or equal to 30%
Joint Separated Large	Deposits Settled Fine, greater than 20%, less than or equal to 30%	Intruding Seal Material Sealing Ring Broken, greater than 20%, less than or equal to 30%
Joint Angular Large	Deposits Settled Gravel, greater than 20%, less than or equal to 30%	Intruding Seal Material Sealing Loose, Poorly Fitting, greater than 30%
Surface Damage Aggregate Missing	Obstruction Brick or Masonry, greater than 20%, less than or equal to 30%	Intruding Sealing Material Grout, greater than 20%, less than or equal to 30%
Surface Damage Reinforcement Visible	Obstruction Pipe Material in Invert, greater than 20%, less than or equal to 30%	Intruding Sealing Material Other, greater than 20%, less than or equal to 30%
Point Repair Liner Defective	Obstruction Wedged in Joint, greater than 20%, less than or equal to 30%	Line Left, greater than 20%
Point Repair Patch Defective	Obstruction Through Connection, greater than 20%, less than or equal to 30%	Line Left/Up, greater than 20%
Point Repair Replacement Defective	Obstruction External Pipe or Cable, greater than 20%, less than or equal to 30%	Line Left/Down, greater than 20%
Point Repair Other Defective	Obstruction Built into Structure, greater than 20%, less than or equal to 30%	Line Right, greater than 20%
Missing Brick	Obstruction Construction Debris, greater than 20%, less than or equal to 30%	Line Right/Up, greater than 20%
Miscellaneous Water Level Sag, greater than 50%, less than or equal to 75%	Obstacle/Obstruction Rocks, greater than 20%, less than or equal to 30%	Line Right/Down, greater than 20%
	Obstacle/Obstruction Other Objects, greater than 20%, less than or equal to 30%	Line Up, greater than 20%
	Tap Factory Intruding, greater than 20%, less than or equal to 30%	Line Down, greater than 20%

# Appendix G. Prioritized List of Mains

UNITID	UNITID2	MATERIAL	DIAMETER	UP DEPTH	DOWN DEPTH	PIPE LENGTH	Drainage Basin	Backbone Pipe	Quarterly Maintenance	Pipe Diameter COF	Pipe Depth COF	Road Type COF	Seismic Backbone COF	Impact on Water Bodies COF	Weighted COF	Estimated Install Year	Estimated Pipe Age	Estimated Remaining Useful Life	LOF Based on Remaining Useful Life	PACP Quick Score (Overall)	PACP Based LOF (Rounded)	Final LOF	Risk
1019	1018	CP	27	15.75	13	234.6	Sewer Drainage Basin #1	Yes		6	4	6	6	6	5.80	1963	57	18	5		0	5	29.0
1020	1019	CP	27	11.92	15.75	309.6	Sewer Drainage Basin #1	Yes		6	4	6	6	6	5.80	1963	57	18	5		0	5	29.0
1015	1014	CP	24	7.6	21.42	190.5	Sewer Drainage Basin #1	Yes		6	5	5	6	6	5.75	1963	57	18	5		0	5	28.8
1014	1013	CP	24	21.5	18.66	174.0	Sewer Drainage Basin #1	Yes		6	5	5	6	6	5.75	1963	57	18	5		0	5	28.8
5109	5003	PVC	15	0	0	191.0	Sewer Drainage Basin #5	Yes		4	1	5	6	2	4.75	1900	120	-45	6		0	6	28.5
1058	1057	CP	12	15.42	16	317.4	Sewer Drainage Basin #1	Yes	Jetting Llnes	3	4	4	6	1	4.65	1963	57	18	5		0	6	27.9
2371	2000	CP	24	24	21.5	146.6	Sewer Drainage Basin #2	Yes		2	6	4	6	1	4.65	1941	79	-4	6		0	6	27.9
1081	1015	CP	24	13	7.6	21.4	Sewer Drainage Basin #1	Yes		6	3	5	6	6	5.55	1963	57	18	5		0	5	27.8
5117	5116	PVC	15	12.9	0	259.0	Sewer Drainage Basin #5	Yes		4	3	3	6	1	4.60	1900	120	-45	6		0	6	27.6
5115	5114	PVC	15	12.41	0	142.4	Sewer Drainage Basin #5	Yes		4	3	3	6	1	4.60	1900	120	-45	6		0	6	27.6
5111	5110	PVC	15	0	0	261.5	Sewer Drainage Basin #5	Yes		4	1	3	6	2	4.45	1900	120	-45	6		0	6	26.7
5116	5115	PVC	15	0	0	185.1	Sewer Drainage Basin #5	Yes		4	1	3	6	1	4.40	1900	120	-45	6		0	6	26.4
5112	5111	PVC	15	0	0	291.9	Sewer Drainage Basin #5	Yes		4	1	3	6	1	4.40	1900	120	-45	6		0	6	26.4
5108	5111	XXX	0	0	0	38.2	Sewer Drainage Basin #5	Yes		4	1	3	6	1	4.40	1900	120	-45	6		0	6	26.4
1063	1062	CP	8	15.25	14.08	203.5	Sewer Drainage Basin #1	Yes	Jetting Llnes	2	4	3	6	1	4.30	1963	57	18	5		0	6	25.8
1006	1005	RCP	24	17.5	7.33	152.5	Sewer Drainage Basin #1	Yes		6	4	1	6	6	5.05	1963	57	18	5		0	5	25.3
2006	2005	CP	18	7.4	9.5	383.0	Sewer Drainage Basin #2	Yes		4	2	5	6	6	5.05	1941	79	-4	6	5141	5	5	25.3
1008	1006	RCP	24	9.75	17.5	259.7	Sewer Drainage Basin #1	Yes		6	4	1	6	6	5.05	1963	57	18	5		0	5	25.3
2342	2000	VCP	8	11.7	11.7	41.5	Sewer Drainage Basin #2	Yes		1	3	4	6	1	4.15	1941	79	-4	6		0	6	24.9
5110	5109	PVC	15	0	0	251.2	Sewer Drainage Basin #5	Yes		1	1	5	6	2	4.15	1900	120	-45	6		0	6	24.9
1078	1077	CP	24	12.2	8.35	81.7	Sewer Drainage Basin #1	Yes		6	3	1	6	6	4.95	1963	57	18	5		0	5	24.8
1016	1015	CP	24	10.75	10.58	113.5	Sewer Drainage Basin #1	Yes		6	3	1	6	6	4.95	1963	57	18	5		0	5	24.8
1084	1083	CP	24	7.25	10.5	149.3	Sewer Drainage Basin #1	Yes		6	3	1	6	6	4.95	1963	57	18	5		0	5	24.8
1017	1016	CP	24	13	10.75	137.2	Sewer Drainage Basin #1	Yes		6	3	1	6	6	4.95	1963	57	18	5		0	5	24.8
1053	1052	CP	15	21.75	21	404.9	Sewer Drainage Basin #1	Yes		4	5	4	6	1	4.95	1963	57	18	5		0	5	24.8
2004	2003	PE	16	14	18.25	298.1	Sewer Drainage Basin #2	Yes		4	5	4	6	1	4.95	2013	7	68	1	4600	5	5	24.8
5119	5118	PVC	15	0	0	196.7	Sewer Drainage Basin #5	Yes		4	1	1	6	1	4.10	1900	120	-45	6		0	6	24.6
5118	5117	PVC	15	0	0	187.7	Sewer Drainage Basin #5	Yes		4	1	1	6	1	4.10	1900	120	-45	6		0	6	24.6
5114	5113	PVC	15	0	0	135.1	Sewer Drainage Basin #5	Yes		4	1	1	6	1	4.10	1900	120	-45	6		0	6	24.6
5113	5112	PVC	15	0	0	182.6	Sewer Drainage Basin #5	Yes		4	1	1	6	1	4.10	1900	120	-45	6		0	6	24.6
1018	1017	CP	24	10.08	13	26.7	Sewer Drainage Basin #1	Yes		2	3	6	6	6	4.90	1963	57	18	5		0	5	24.5
1021	1020	CP	24	11.42	11.92	182.7	Sewer Drainage Basin #1	Yes		6	3	1	6	5	4.90	1963	57	18	5		0	5	24.5
1005	1004	RCP	24	7.33	0	504.3	Sewer Drainage Basin #1	Yes		6	2	1	6	6	4.85	1963	57	18	5		0	5	24.3
1022	1567	CP	24	6.33	6.33	29.2	Sewer Drainage Basin #1	Yes		6	2	1	6	6	4.85	1963	57	18	5		0	5	24.3
1077	1005	CP	24	8.3	7.33	81.2	Sewer Drainage Basin #1	Yes		6	2	1	6	6	4.85	1963	57	18	5		0	5	24.3
1047	1046	CP	15	13.83	14.42	364.7	Sewer Drainage Basin #1	Yes		4	4	4	6	1	4.85	1963	57	18	5		0	5	24.3
1046	1045	XXX	15	14	11.25	436.0	Sewer Drainage Basin #1	Yes		4	4	4	6	1	4.85	1963	57	18	5		0	5	24.3
1048	1047	CP	15	20.08	13.83	357.4	Sewer Drainage Basin #1	Yes		4	5	3	6	1	4.80	1963	57	18	5		0	5	24.0
1049	1048	CP	15	20.7	20.1	366.2	Sewer Drainage Basin #1	Yes		4	5	3	6	1	4.80	1963	57	18	5		0	5	24.0
1050	1049	CP	15	20.83	20.58	361.6	Sewer Drainage Basin #1	Yes		4	5	3	6	1	4.80	1963	57	18	5		0	5	24.0
1051	1050	CP	15	19.83	20.83	264.9	Sewer Drainage Basin #1	Yes		4	5	3	6	1	4.80	1963	57	18	5		0	5	24.0
1052	1051	CP	15	20.33	19.83	402.7	Sewer Drainage Basin #1	Yes		4	5	3	6	1	4.80	1963	57	18	5		0	5	24.0
3511	3931	PVC	10	10.2	10.7	23.4	Sewer Drainage Basin #3	Yes		3	3	4	6	6	4.80	2007	13	62	2	5100	5	5	24.0
1004	1003	DIP	24	0	0	114.0	Sewer Drainage Basin #1	Yes		6	1	1	6	6	4.75	1963	57	18	5		0	5	23.8
1003	CCMH036	CSU	24	0	0	133.0	Sewer Drainage Basin #1	Yes		6	1	1	6	6	4.75	1963	57	18	5		0	5	23.8
1010	1008	RCP	24	0	0	64.8	Sewer Drainage Basin #1	Yes		6	1	1	6	6	4.75	1963	57	18	5		0	5	23.8
1011	1010	RCP	24	0	0	82.8	Sewer Drainage Basin #1	Yes		6	1	1	6	6	4.75	1963	57	18	5		0	5	23.8
1054	1053	CP	12	19.17	21.75	153.8	Sewer Drainage Basin #1	Yes		3	5	4	6	1	4.75	1963	57	18	5		0	5	23.8
2343	2006	CP	8	6.88	10.33	227.0	Sewer Drainage Basin #2	Yes		2	3	5	6	6	4.75	1941	79	-4	6	522E	5	5	23.8
1055	1054	CP	12	15.17	19.17	249.4	Sewer Drainage Basin #1	Yes		3	5	4	6	1	4.75	1963	57	18	5		0	5	23.8
1307	1053	CP	12	11	21.75	154.2	Sewer Drainage Basin #1	Yes		3	5	4	6	1	4.75	1963	57	18	5		0	5	23.8
VLT1578	1021	CP	24	11.43	11.43	52.1	Sewer Drainage Basin #1	Yes		6	3	1	6	2	4.75	1963	57	18	5		0	5	23.8
1292	1044	CP	15	9.8	10	84.2	Sewer Drainage Basin #1	Yes		4	3	4	6	1	4.75	1963	57	18	5		0	5	23.8
1045	1044	CP	15	11.25	12.5	214.1	Sewer Drainage Basin #1	Yes		4	3	4	6	1	4.75	1963	57	18	5		0	5	23.8
5121	5120	PVC	15	0	0	253.0	Sewer Drainage Basin #5	Yes		3	1	1	6	2	3.95	1900	120	-45	6		0	6	23.7
2014	2013	PE	10	11.58	11	109.5	Sewer Drainage Basin #2	Yes		3	3	5	6	1	4.70	2013	7	68	1	4800	5	5	23.5
2019	2018	CP	10	12.25	10.58	428.3	Sewer Drainage Basin #2	Yes		3	3	5	6	1	4.70	1941	79	-4	6	5141	5	5	23.5
1575	1144	CP	8	9.5	10	141.3	Sewer Drainage Basin #1	Yes		2	3	6	6	2	4.70	1963	57	18	5	513E	5	5	23.5
1130	1118	CP	6	5.83	6.83	151.1	Sewer Drainage Basin #1	Yes		1	2	3	6	1	3.90	1963	57	18	5	5741	6	6	23.4
1056	1055	CP	12	15.17	15.17	74.1	Sewer Drainage Basin #1	Yes		3	4	4	6	1	4.65	1963	57	18	5		0	5	23.3
1057	1056	CP	12	16	11.8	418.1	Sewer Drainage Basin #1	Yes		3	4	4	6	1	4.65	1963	57	18	5		0	5	23.3
1059	1058	CP	10	15.25	15.41	318.1	Sewer Drainage Basin #1	Yes		3	4	4	6	1	4.65	1963	57	18	5		0	5	23.3
3512	3511	CP	8	8.42	10.17	325.2	Sewer Drainage Basin #3	Yes	Jetting Llnes	2	3	4	6	6	4.60	1969	51	24	4	4A00	5	5	23.0
3026	3025	CP	15	13.17	13	356.6	Sewer Drainage Basin #3	Yes		4	3	3	6	1	4.60	1969	51	24	4	5141	5	5	23.0
1036	1035	CP	18	13.75	10	381.2	Sewer Drainage Basin #1	Yes		4	3	3	6	1	4.60	1963	57	18	5	5122	5	5	23.0
1044	1043	CP	12	12.5	7.3	387.7	Sewer Drainage Basin #1	Yes		3	3	4	6	1	4.55	1963	57	18	5		0	5	22.8
1308	1307	CP	12	12	11	160.8	Sewer Drainage Basin #1	Yes		3	3	4	6	1	4.55	1963	57	18	5		0	5	22.8
1311	1308	CP	12	11.83	12	114.5	Sewer Drainage Basin #1	Yes		3	3	4	6	1	4.55	1963	57	18</					



UNITID	UNITID2	MATERIAL	DIAMETER	UP DEPTH	DOWN DEPTH	PIPE LENGTH	Drainage Basin	Backbone Pipe	Quarterly Maintenance	Pipe Diameter COF	Pipe Depth COF	Road Type COF	Seismic Backbone COF	Impact on Water Bodies COF	Weighted COF	Estimated Install Year	Estimated Pipe Age	Estimated Remaining Useful Life	LOF Based on Remaining Useful Life	PACP Quick Score (Overall)	PACP Based LOF (Rounded)	Final LOF	Risk
2082	2081	CP	10	9.25	7.83	337.0	Sewer Drainage Basin #2	Yes		3	2	4	6	1	4.45	1941	79	-4	6	4A2A	5	5	22.3
1060	1059	CP	8	10.75	15.08	352.4	Sewer Drainage Basin #1	Yes		2	4	4	6	1	4.45	1963	57	18	5		0	5	22.3
1120	1576	CP	12	8.83	7.66	282.1	Sewer Drainage Basin #1	Yes		3	2	3	6	4	4.45	1963	57	18	5	5127	5	5	22.3
1328	1055	CP	8	10.5	15.17	257.9	Sewer Drainage Basin #1	Yes		2	4	4	6	1	4.45	1963	57	18	5		0	5	22.3
3143	3142	CP	12	8.33	9	237.7	Sewer Drainage Basin #3	Yes		3	2	4	6	1	4.45	1969	51	24	4	5100	5	5	22.3
3043	3042	CP	8	9.25	8.92	548.6	Sewer Drainage Basin #3	Yes	Flushing Lines	3	2	4	6	1	4.45	1969	51	24	4		0	5	22.3
1030	1029	CP	20	9.66	9.33	404.6	Sewer Drainage Basin #1	Yes		3	2	4	6	1	4.45	1963	57	18	5	533A	5	5	22.3
1907	1257	CP	8	12.8	18.4	277.3	Sewer Drainage Basin #1	Yes		2	5	3	6	1	4.40	1963	57	18	5		0	5	22.0
1066	1065	CP	10	13.6	13.8	48.5	Sewer Drainage Basin #1	Yes		3	3	3	6	1	4.40	1963	57	18	5		0	5	22.0
1041	1040	CP	12	12.25	10.58	351.4	Sewer Drainage Basin #1	Yes		3	3	3	6	1	4.40	1963	57	18	5		0	5	22.0
1252	1040	CP	12	11.66	10.58	269.4	Sewer Drainage Basin #1	Yes		3	3	3	6	1	4.40	1963	57	18	5		0	5	22.0
1255	1254	CP	12	7.83	10.3	268.8	Sewer Drainage Basin #1	Yes		3	3	3	6	1	4.40	1963	57	18	5		0	5	22.0
1256	1255	CP	12	10.16	7.83	267.3	Sewer Drainage Basin #1	Yes		3	3	3	6	1	4.40	1963	57	18	5		0	5	22.0
1257	1906	CP	8	18.4	6.45	208.8	Sewer Drainage Basin #1	Yes		2	5	3	6	1	4.40	1963	57	18	5		0	5	22.0
1070	1069	CP	8	11.7	18	293.0	Sewer Drainage Basin #1	Yes		2	5	3	6	1	4.40	1963	57	18	5		0	5	22.0
1071	1070	CP	8	20	11.58	189.3	Sewer Drainage Basin #1	Yes		2	5	3	6	1	4.40	1963	57	18	5		0	5	22.0
1072	1071	CP	8	16.95	20	106.1	Sewer Drainage Basin #1	Yes		2	5	3	6	1	4.40	1963	57	18	5		0	5	22.0
1253	1252	CP	12	12.5	11.66	269.0	Sewer Drainage Basin #1	Yes		3	3	3	6	1	4.40	1963	57	18	5		0	5	22.0
1123	1122	PVC	10	4.58	4.83	218.2	Sewer Drainage Basin #1	Yes		3	1	3	6	5	4.40	1963	57	18	5	5133	5	5	22.0
1254	1903	CP	12	10.3	11.33	269.5	Sewer Drainage Basin #1	Yes		3	3	3	6	1	4.40	1963	57	18	5		0	5	22.0
1903	1253	CP	12	11.33	12.5	264.7	Sewer Drainage Basin #1	Yes		3	3	3	6	1	4.40	1963	57	18	5		0	5	22.0
1037	1036	CP	12	13.2	13.75	169.3	Sewer Drainage Basin #1	Yes		3	3	3	6	1	4.40	1963	57	18	5		0	5	22.0
3349	3348	CP	10	7.4	4.8	170.0	Sewer Drainage Basin #3	Yes		1	2	5	6	5	4.40	1969	51	24	4	5141	5	5	22.0
1025	1024	CP	24	10	4.42	218.2	Sewer Drainage Basin #1	Yes		6	3	6	6	1	5.45	1963	57	18	5	3611	4	4	21.8
2025	2005	VCP	8	11.4	9.91	117.8	Sewer Drainage Basin #2	Yes		2	3	4	6	1	4.35	1941	79	-4	6	5141	5	5	21.8
1306	1046	CP	8	9.7	11.83	229.8	Sewer Drainage Basin #1	Yes		2	3	4	6	1	4.35	1963	57	18	5		0	5	21.8
1156	1155	CP	8	5.33	7.66	308.8	Sewer Drainage Basin #1	Yes		2	2	4	6	2	4.30	1963	57	18	5	513B	5	5	21.5
1329	1328	CP	8	14	10.5	268.0	Sewer Drainage Basin #1	Yes		2	4	3	6	1	4.30	1963	57	18	5		0	5	21.5
1064	1923	CP	8	14.5	14.83	275.2	Sewer Drainage Basin #1	Yes		2	4	3	6	1	4.30	1963	57	18	5		0	5	21.5
1068	1067	CP	8	10	15	367.4	Sewer Drainage Basin #1	Yes		2	4	3	6	1	4.30	1963	57	18	5		0	5	21.5
1062	1061	CP	8	14.08	12.5	211.0	Sewer Drainage Basin #1	Yes		2	4	3	6	1	4.30	1963	57	18	5		0	5	21.5
1073	1072	CP	8	16.8	12.5	385.1	Sewer Drainage Basin #1	Yes		2	4	3	6	1	4.30	1963	57	18	5		0	5	21.5
1074	1073	CP	8	12.5	16.8	194.7	Sewer Drainage Basin #1	Yes		2	4	3	6	1	4.30	1963	57	18	5		0	5	21.5
1116	1118	CP	12	7.33	6.83	192.4	Sewer Drainage Basin #1	Yes		3	2	3	6	1	4.30	1963	57	18	5	513A	5	5	21.5
1196	1037	CP	8	9.17	13.2	177.4	Sewer Drainage Basin #1	Yes		2	3	3	6	3	4.30	1963	57	18	5	5141	5	5	21.5
1923	1063	CP	8	14.83	15.25	276.1	Sewer Drainage Basin #1	Yes		2	4	3	6	1	4.30	1963	57	18	5		0	5	21.5
1067	1066	CP	8	14.75	13.6	209.3	Sewer Drainage Basin #1	Yes		2	4	3	6	1	4.30	1963	57	18	5		0	5	21.5
1296-CO	1292	CP	8	0	9.8	157.5	Sewer Drainage Basin #1	Yes		2	2	4	6	1	4.25	1963	57	18	5		0	5	21.3
N1046	1046	CP	8	0	9	146.2	Sewer Drainage Basin #1	Yes		2	2	4	6	1	4.25	1963	57	18	5		0	5	21.3
SV1006	1311	CAS	8	0	0	1900.1	Sewer Drainage Basin #1	Yes		1	1	5	6	4	4.25	1963	57	18	5		0	5	21.3
3003	CCMH039	CP	18	18.5	0	153.4	Sewer Drainage Basin #3	Yes		4	5	5	6	5	5.30	1969	51	24	4		0	4	21.2
1508	1042	CP	8	8.8	13.16	350.2	Sewer Drainage Basin #1	Yes		2	3	3	6	1	4.20	1963	57	18	5		0	5	21.0
2115	2108	CP	8	7.33	10.33	512.9	Sewer Drainage Basin #2	Yes		2	3	3	6	1	4.20	1941	79	-4	6	513D	5	5	21.0
1331	1330	CP	8	10.4	10.4	228.0	Sewer Drainage Basin #1	Yes		2	3	3	6	1	4.20	1963	57	18	5		0	5	21.0
1332	1331	CP	8	11.8	10.4	245.3	Sewer Drainage Basin #1	Yes		2	3	3	6	1	4.20	1963	57	18	5		0	5	21.0
1333	1332	CP	8	9	11.8	344.5	Sewer Drainage Basin #1	Yes		2	3	3	6	1	4.20	1963	57	18	5		0	5	21.0
2123	2110	CP	8	11.92	9.17	555.9	Sewer Drainage Basin #2	Yes		2	3	3	6	1	4.20	1941	79	-4	6	5141	5	5	21.0
1258	1907	CP	8	12.4	12.8	248.1	Sewer Drainage Basin #1	Yes		2	3	3	6	1	4.20	1963	57	18	5		0	5	21.0
1288	1258	CP	8	7.4	12.4	178.0	Sewer Drainage Basin #1	Yes		2	3	3	6	1	4.20	1963	57	18	5		0	5	21.0
2088	2087	CP	8	13.58	8.5	335.5	Sewer Drainage Basin #2	Yes		2	3	3	6	1	4.20	1941	79	-4	6	512A	5	5	21.0
2308	2086	CP	8	8.33	12.83	162.6	Sewer Drainage Basin #2	Yes		2	3	3	6	1	4.20	1941	79	-4	6	512D	5	5	21.0
1061	1060	CP	8	12.5	10.75	214.9	Sewer Drainage Basin #1	Yes		2	3	3	6	1	4.20	1963	57	18	5		0	5	21.0
1906	1256	CP	8	9	10.2	273.4	Sewer Drainage Basin #1	Yes		2	3	3	6	1	4.20	1963	57	18	5		0	5	21.0
1069	1068	CP	8	11.7	10	259.0	Sewer Drainage Basin #1	Yes		2	3	3	6	1	4.20	1963	57	18	5		0	5	21.0
1075	1586	CP	8	11.6	12.8	100.2	Sewer Drainage Basin #1	Yes		2	3	3	6	1	4.20	1963	57	18	5		0	5	21.0
1586	1074	CP	8	12.8	12.5	73.3	Sewer Drainage Basin #1	Yes		2	3	3	6	1	4.20	1967	53	22	5		0	5	21.0
1157	1156	CP	8	4.83	5.33	449.6	Sewer Drainage Basin #1	Yes	Jetting Lines	2	1	4	6	1	4.15	1963	57	18	5	544B	5	5	20.8
1567	VLT1578	CP	24	6.33	11.43	358.5	Sewer Drainage Basin #1	Yes		2	3	1	6	6	4.15	1963	57	18	5		0	5	20.8
3006	3005	CP	15	19	20	190.0	Sewer Drainage Basin #3	Yes		2	5	1	6	2	4.15	1969	51	24	4	5100	5	5	20.8
1012	1002	DIP	12	21.33	0	490.8	Sewer Drainage Basin #1	Yes		1	5	1	6	6	4.15	1963	57	18	5		0	5	20.8
1509	1042	CP	8	8.33	5.8	200.4	Sewer Drainage Basin #1	Yes		2	2	3	6	1	4.10	1963	57	18	5		0	5	20.5
3371	3370	CP	8	9.75	8.33	184.1	Sewer Drainage Basin #3	Yes		2	2	3	6	1	4.10	1969	51	24	4	5428	5	5	20.5
2117	2116	CP	8	7.75	6.92	509.9	Sewer Drainage Basin #2	Yes		2	2	3	6	1	4.10	1941	79	-4	6	5141	5	5	20.5
1587	1586	PVC	8	7	6.1	279.2	Sewer Drainage Basin #1	Yes		2	2	3	6	1	4.10	1963	57	18	5		0	5	20.5
2079	2078	CP	8	8.42	8.33	437.9	Sewer Drainage Basin #2	Yes		2	2	3	6	1	4.10	1941	79	-4	6	5141	5	5	20.5
1330	1329	CP	8	10.4	14	225.3	Sewer Drainage Basin #1	Yes		1	4	3	6	1	4.10	1963	57	18	5		0	5	20.5
1085	1084	CP	8	4.9	7.42	117.6	Sewer Drainage Basin #1	Yes		2	2	1	6	6	4.05	1963	57	18	5		0	5	20.3
2125	2124	CP	8	0	0	315.0	Sewer Drainage Basin #1	Yes		2	1												

UNITID	UNITID2	MATERIAL	DIAMETER	UP DEPTH	DOWN DEPTH	PIPE LENGTH	Drainage Basin	Backbone Pipe	Quarterly Maintenance	Pipe Diameter COF	Pipe Depth COF	Road Type COF	Seismic Backbone COF	Impact on Water Bodies COF	Weighted COF	Estimated Install Year	Estimated Pipe Age	Estimated Remaining Useful Life	LOF Based on Remaining Useful Life	PACP Quick Score (Overall)	PACP Based LOF (Rounded)	Final LOF	Risk
1028	1027	CP	20	9.33	9	297.2	Sewer Drainage Basin #1	Yes		5	2	4	6	1	4.85	1963	57	18	5	3C22	4	4	19.4
1029	1028	CP	20	9.33	9.33	362.0	Sewer Drainage Basin #1	Yes		5	2	4	6	1	4.85	1963	57	18	5	4132	4	4	19.4
2029	2005	PE	8	9.58	9.91	282.3	Sewer Drainage Basin #2	Yes		4	2	5	6	2	4.85	2013	7	68	1	4533	4	4	19.4
1636	1634	PVC	12	13.5	11.42	184.0	Sewer Drainage Basin #1B	Yes		3	3	5	6	4	4.85	1972	48	27	4		0	4	19.4
1635	1636	PVC	12	13.25	13.5	33.2	Sewer Drainage Basin #1B	Yes		3	3	5	6	4	4.85	1972	48	27	4		0	4	19.4
2146	2145	PE	12	14	8.5	307.2	Sewer Drainage Basin #2	Yes		3	4	5	6	1	4.80	2018	2	73	1	4100	4	4	19.2
5002	5001	CP	12	13.6	6	245.7	Sewer Drainage Basin #5	Yes		3	3	5	6	2	4.75	1973	47	28	4		0	4	19.0
3515	3131	CP	15	8.6	10.33	105.5	Sewer Drainage Basin #3	Yes		4	3	4	6	1	4.75	1969	51	24	4	4100	4	4	19.0
3348	3347	CP	10	4.8	9.6	263.5	Sewer Drainage Basin #3	Yes		3	2	5	6	4	4.75	1969	51	24	4	4100	4	4	19.0
5014	5002	CP	8	18.4	13.6	212.7	Sewer Drainage Basin #5	Yes		2	5	5	6	1	4.70	1973	47	28	4		0	4	18.8
2018	2017	CP	10	10.58	8.9	548.7	Sewer Drainage Basin #2	Yes		3	3	5	6	1	4.70	1941	79	-4	6	413D	4	4	18.8
2148	2147	CP	12	10.5	13.67	541.8	Sewer Drainage Basin #2	Yes		3	3	5	6	1	4.70	1941	79	-4	6	413K	4	4	18.8
1023	1022	CP	0	0	0	80.7	Sewer Drainage Basin #1	Yes		1	1	1	6	6	3.75	1963	57	18	5		0	5	18.8
3157	3158	CP	8	17.67	25.67	429.8	Sewer Drainage Basin #3	Yes		2	6	4	6	1	4.65	1969	51	24	4		0	4	18.6
3159	3158	CP	8	25.5	25.4	40.0	Sewer Drainage Basin #3	Yes		2	6	4	6	1	4.65	1969	51	24	4		0	4	18.6
3158	3288	CP	8	25.4	25.8	31.5	Sewer Drainage Basin #3	Yes		2	6	4	6	1	4.65	1969	51	24	4		0	4	18.6
1417	1635	CP	8	12.9	13.3	53.1	Sewer Drainage Basin #1B	Yes		2	3	5	6	4	4.65	1972	48	27	4		0	4	18.6
3381	3380	CP	8	14	13.67	47.2	Sewer Drainage Basin #3	Yes		2	4	5	6	1	4.60	1969	51	24	4		0	4	18.4
3380	3379	CP	8	13.67	14.92	152.8	Sewer Drainage Basin #3	Yes		2	4	5	6	1	4.60	1969	51	24	4		0	4	18.4
3379	3378	CP	8	14.92	11.6	253.3	Sewer Drainage Basin #3	Yes		2	4	5	6	1	4.60	1969	51	24	4		0	4	18.4
1573	1565	CP	8	7.83	9.5	282.6	Sewer Drainage Basin #1	Yes		2	2	6	6	2	4.60	1963	57	18	5	3K00	4	4	18.4
3523	3166	CP	8	16.7	15.2	97.0	Sewer Drainage Basin #3	Yes		2	4	5	6	1	4.60	1969	51	24	4	4131	4	4	18.4
2080	2017	CP	10	8.25	8.11	340.0	Sewer Drainage Basin #2	Yes		3	2	5	6	1	4.60	1941	79	-4	6	422C	4	4	18.4
3382	3381	CP	8	4.6	14	312.4	Sewer Drainage Basin #3	Yes		2	4	5	6	1	4.60	1969	51	24	4		0	4	18.4
3146	3145	CP	12	7.17	8	329.0	Sewer Drainage Basin #3	Yes		3	2	4	6	3	4.55	1969	51	24	4		0	4	18.2
2222	2323	CP	12	13.33	13.83	124.7	Sewer Drainage Basin #2	Yes		3	3	4	6	1	4.55	1941	79	-4	6	442C	4	4	18.2
3131	3003	CP	8	18.7	18.5	110.3	Sewer Drainage Basin #3	Yes		2	5	4	6	1	4.55	1969	51	24	4		0	4	18.2
2106	2018	CP	8	9.58	10.58	513.7	Sewer Drainage Basin #2	Yes		2	3	5	6	1	4.50	1941	79	-4	6	413B	4	4	18.0
3378	3377	CP	8	11.67	7.89	312.8	Sewer Drainage Basin #3	Yes		2	3	5	6	1	4.50	1969	51	24	4		0	4	18.0
4061	4060	CP	10	14.9	15.5	139.5	Sewer Drainage Basin #4	Yes		3	4	3	6	1	4.50	1974	46	29	4	413A	4	4	18.0
3152	3151	CP	12	11.5	15.33	300.9	Sewer Drainage Basin #3	Yes		3	4	3	6	1	4.50	1969	51	24	4	4100	4	4	18.0
3162	3161	CP	8	11	26.5	257.1	Sewer Drainage Basin #3	Yes		2	6	3	6	1	4.50	1969	51	24	4	4124	4	4	18.0
1121	1120	CP	12	8.75	8.83	233.3	Sewer Drainage Basin #1	Yes		3	2	3	6	5	4.50	1963	57	18	5	423B	4	4	18.0
1600	1121	CP	12	4.83	8.75	228.6	Sewer Drainage Basin #1	Yes		3	2	3	6	5	4.50	1963	57	18	5	4231	4	4	18.0
3004	3003	XXX	15	0	18.5	284.9	Sewer Drainage Basin #3	Yes		4	5	1	6	1	4.50	1969	51	24	4		0	4	18.0
2310	2082	CP	10	8.1	9.25	220.2	Sewer Drainage Basin #2	Yes		3	2	4	6	1	4.45	1941	79	-4	6	4134	4	4	17.8
1635	SV1008	CP	8	0	0	6.0	Sewer Drainage Basin #1B	Yes		2	1	5	6	4	4.45	1972	48	27	4		0	4	17.8
3377	3376	CP	8	7.89	6.67	194.9	Sewer Drainage Basin #3	Yes		2	2	5	6	1	4.40	1969	51	24	4		0	4	17.6
5015	5014	DIP	8	17	18.25	111.3	Sewer Drainage Basin #5	Yes		2	5	3	6	1	4.40	1973	47	28	4		0	4	17.6
5017	5016	CP	8	9.83	11	251.3	Sewer Drainage Basin #5	Yes		2	3	3	6	5	4.40	1973	47	28	4		0	4	17.6
4059	4058	CP	8	19.5	14.3	166.6	Sewer Drainage Basin #4	Yes		2	5	3	6	1	4.40	1974	46	29	4	3D00	4	4	17.6
1122	1600	PVC	10	4.83	4.83	216.7	Sewer Drainage Basin #1	Yes		3	1	3	6	5	4.40	1963	57	18	5	3F21	4	4	17.6
2085	2084	CP	8	13.83	8.66	299.2	Sewer Drainage Basin #2	Yes		2	3	4	6	1	4.35	1941	79	-4	6	4131	4	4	17.4
1012	1011	DIP	12	21.33	0	684.0	Sewer Drainage Basin #1	Yes		2	5	1	6	6	4.35	1975	45	30	4		0	4	17.4
5016	5015	CP	8	11	17	197.4	Sewer Drainage Basin #5	Yes		2	4	3	6	1	4.30	1973	47	28	4		0	4	17.2
4058	4057	CP	8	14.3	7.3	178.8	Sewer Drainage Basin #4	Yes		2	4	3	6	1	4.30	1974	46	29	4	423C	4	4	17.2
1429	1428	CP	10	7.5	7.2	142.6	Sewer Drainage Basin #1B	Yes		3	2	3	6	1	4.30	1972	48	27	4		0	4	17.2
4917	4061	CP	8	12.2	14.9	165.9	Sewer Drainage Basin #4	Yes		2	4	3	6	1	4.30	1974	46	29	4	4121	4	4	17.2
5000	1900	CP	12	6.8	8.5	362.4	Sewer Drainage Basin #5	Yes		3	2	1	6	6	4.25	1973	47	28	4		0	4	17.0
1117	1567	CP	12	3.25	6.33	280.2	Sewer Drainage Basin #1	Yes		3	2	1	6	6	4.25	1963	57	18	5	422J	4	4	17.0
2081	2080	CP	10	9.25	7.83	315.2	Sewer Drainage Basin #2	Yes		2	2	4	6	1	4.25	1941	79	-4	6	4126	4	4	17.0
3488	3487	PVC	8	7	11.5	45.5	Sewer Drainage Basin #3	Yes		2	3	3	6	1	4.20	1969	51	24	4		0	4	16.8
2109	2108	CP	8	10	10.33	344.3	Sewer Drainage Basin #2	Yes		2	3	3	6	1	4.20	1941	79	-4	6	362L	4	4	16.8
1192	1034	CP	8	5.5	5.4	370.7	Sewer Drainage Basin #1	Yes	Flushing Lines	3	1	3	6	1	4.20	1963	57	18	5	4133	4	4	16.8
4069	4068	CP	8	9	12	378.2	Sewer Drainage Basin #4	Yes		2	3	3	6	1	4.20	1974	46	29	4	3A24	4	4	16.8
1532	1423	PVC	8	5.5	10.3	93.1	Sewer Drainage Basin #1B	Yes		2	3	3	6	1	4.20	1972	48	27	4		0	4	16.8
5075	5117	PVC	8	8.3	12.9	57.8	Sewer Drainage Basin #5	Yes		2	3	3	6	1	4.20	1973	47	28	4		0	4	16.8
NSV1013	3154	XXX	0	0	0	1072.6	Sewer Drainage Basin #3	Yes		2	1	4	6	1	4.15	1969	51	24	4		0	4	16.6
SV1013	NSV1013	XXX	0	0	0	1.5	Sewer Drainage Basin #3	Yes		2	1	4	6	1	4.15	1969	51	24	4		0	4	16.6
1002	1011	DIP	12	0	0	192.9	Inaccessible For Maintenance	Yes		3	1	1	6	6	4.15	1975	45	30	4		0	4	16.6
3351	3350	CP	8	6.25	5.75	126.8	Sewer Drainage Basin #3	Yes		2	2	3	6	1	4.10	1969	51	24	4	4131	4	4	16.4
5061	5115	CSU	8	6.5	8	29.4	Sewer Drainage Basin #5	Yes		2	2	3	6	1	4.10	1973	47	28	4		0	4	16.4
1467	1424	CP	8	8.1	7.6	297.1	Sewer Drainage Basin #1B	Yes		2	2	3	6	1	4.10	1972	48	27	4		0	4	16.4
2307	2308	CP	8	8.33	8.67	475.8	Sewer Drainage Basin #2	Yes		2	2	3	6	1	4.10	1941	79	-4	6	412P	4	4	16.4
1471	1428	CP	8	6.7	7.2	383.7	Sewer Drainage Basin #1B	Yes		2	2	3	6	1	4.10	1972	48	27	4		0	4	16.4
2119	2118	CP	8	6.83	5.67	243.0	Sewer Drainage Basin #2	Yes		2	2	3	6	1	4.10	1941	79	-4	6	4222	4	4	16.4
2118	2116	CP	8	5.67	6.92	330.8	Sewer Drainage Basin #2	Yes		2	2	3	6	1	4.10	1941	79	-4	6	4100	4	4	16.4
2907	2130	CP	8	9.25	8.92	394.1	Sewer Drainage Basin #2																

UNITID	UNITID2	MATERIAL	DIAMETER	UP DEPTH	DOWN DEPTH	PIPE LENGTH	Drainage Basin	Backbone Pipe	Quarterly Maintenance	Pipe Diameter COF	Pipe Depth COF	Road Type COF	Seismic Backbone COF	Impact on Water Bodies COF	Weighted COF	Estimated Install Year	Estimated Pipe Age	Estimated Remaining Useful Life	LOF Based on Remaining Useful Life	PACP Quick Score (Overall)	PACP Based LOF (Rounded)	Final LOF	Risk
3384	3383	CP	8	3.42	5.42	343.9	Sewer Drainage Basin #3	Yes		2	1	1	6	1	3.70	1969	51	24	4		0	4	14.8
3383	3382	CP	8	5.42	5.33	376.8	Sewer Drainage Basin #3	Yes		2	1	1	6	1	3.70	1969	51	24	4		0	4	14.8
3385	3384	CP	8	4	3.42	61.6	Sewer Drainage Basin #3	Yes		2	1	1	6	1	3.70	1969	51	24	4		0	4	14.8
2016	2015	CP	12	13.42	9.75	419.1	Sewer Drainage Basin #2	Yes		3	3	6	6	1	4.85	1941	79	-4	6	3221	3	3	14.6
2149	2329	CP	12	16.33	15.66	86.0	Sewer Drainage Basin #2	Yes		3	4	5	6	1	4.80	1941	79	-4	6	2A00	3	3	14.4
2150	2149	CP	12	17.33	16.33	228.3	Sewer Drainage Basin #2	Yes		3	4	5	6	1	4.80	1941	79	-4	6	2713	3	3	14.4
2151	2150	CP	10	16.91	17.33	240.6	Sewer Drainage Basin #2	Yes		3	4	5	6	1	4.80	1941	79	-4	6	2C11	3	3	14.4
2329	2148	CP	12	15.66	10.5	298.2	Sewer Drainage Basin #2	Yes		3	4	5	6	1	4.80	1941	79	-4	6	332E	3	3	14.4
1167	1031	CP	10	7.33	9.3	121.3	Sewer Drainage Basin #1	Yes		3	2	6	6	1	4.75	1963	57	18	5	2A00	3	3	14.3
2015	2014	CP	12	9.75	11.58	256.2	Sewer Drainage Basin #2	Yes		3	3	5	6	1	4.70	1941	79	-4	6	3123	3	3	14.1
2017	2016	CP	12	8.92	13.42	312.2	Sewer Drainage Basin #2	Yes		3	3	5	6	1	4.70	1941	79	-4	6	3100	3	3	14.1
2066	2016	CP	12	10.5	13.42	276.0	Sewer Drainage Basin #2	Yes		3	3	5	6	1	4.70	1941	79	-4	6	2100	3	3	14.1
2372	2371	PVC	10	22.5	24	284.4	Sewer Drainage Basin #2	No		3	6	4	1	1	2.35	1941	79	-4	6		0	6	14.1
3298	3159	CP	8	12.25	25.33	301.0	Sewer Drainage Basin #3	Yes		2	6	4	6	1	4.65	1969	51	24	4	2A00	3	3	14.0
3305	3159	CP	8	26.92	25.6	251.9	Sewer Drainage Basin #3	Yes		2	6	4	6	1	4.65	1969	51	24	4	312D	3	3	14.0
2376	2374	PVC	10	14.75	17.08	256.3	Sewer Drainage Basin #2	No		3	4	5	1	1	2.30	1941	79	-4	6		0	6	13.8
1155	1573	CP	8	7.66	7.83	94.1	Sewer Drainage Basin #1	Yes		2	2	6	6	2	4.60	1963	57	18	5	3200	3	3	13.8
3314	3313	CP	8	14	16	183.4	Sewer Drainage Basin #3	Yes		2	4	5	6	1	4.60	1969	51	24	4	2B00	3	3	13.8
4060	4059	CP	10	15.5	19.5	160.5	Sewer Drainage Basin #4	Yes		3	5	3	6	1	4.60	1974	46	29	4	2900	3	3	13.8
1040	1036	CP	18	10.58	13.75	246.6	Sewer Drainage Basin #1	Yes		4	3	3	6	1	4.60	1963	57	18	5	3212	3	3	13.8
3148	3147	CP	12	13	5.33	323.3	Sewer Drainage Basin #3	Yes		3	3	4	6	2	4.60	1969	51	24	4	3100	3	3	13.8
3025	3024	CP	15	13	13.67	340.1	Sewer Drainage Basin #3	Yes		4	3	3	6	1	4.60	1969	51	24	4	3121	3	3	13.8
3032	3031	CP	15	11.5	12.5	219.1	Sewer Drainage Basin #3	Yes		4	3	3	6	1	4.60	1969	51	24	4	3121	3	3	13.8
1565	1566	PVC	8	9.83	9.5	47.4	Sewer Drainage Basin #1	Yes		2	2	6	6	2	4.60	1963	57	18	5	2800	3	3	13.8
3165	3164	CP	8	14.67	15	399.5	Sewer Drainage Basin #3	Yes		2	4	5	6	1	4.60	1969	51	24	4	2C00	3	3	13.8
3315	3314	CP	8	12.25	14	434.2	Sewer Drainage Basin #3	Yes		2	4	5	6	1	4.60	1969	51	24	4	2B11	3	3	13.8
2067	2066	CP	12	10	10.5	271.4	Sewer Drainage Basin #2	Yes		3	3	4	6	1	4.55	1941	79	-4	6	2F00	3	3	13.7
2068	2906	CP	12	10.42	9.42	278.9	Sewer Drainage Basin #2	Yes		3	3	4	6	1	4.55	1941	79	-4	6	2.00E+00	3.00E+00	3	13.7
2906	2067	CP	12	10.42	10	212.3	Sewer Drainage Basin #2	Yes		3	3	4	6	1	4.55	1941	79	-4	6	2C11	3	3	13.7
6007	6006	CP	8	10	9.5	265.1	Sewer Drainage Basin #6	Yes		2	3	5	6	1	4.50	1988	32	43	3		0	3	13.5
6006	6004	PVC	8	9.5	10	307.7	Sewer Drainage Basin #6	Yes		2	3	5	6	1	4.50	1988	32	43	3		0	3	13.5
6002	6001	CP	8	9.5	12.1	74.3	Sewer Drainage Basin #6	Yes		2	3	5	6	1	4.50	1988	32	43	3		0	3	13.5
6004	6002	CP	8	10	9.5	405.8	Sewer Drainage Basin #6	Yes		2	3	5	6	1	4.50	1988	32	43	3		0	3	13.5
1033	1032	CP	18	9.17	9.92	323.6	Sewer Drainage Basin #1	Yes		4	2	3	6	1	4.50	1963	57	18	5	3200	3	3	13.5
3161	3160	CP	8	27	25.83	233.9	Sewer Drainage Basin #3	Yes		2	6	3	6	1	4.50	1969	51	24	4	2B00	3	3	13.5
1119	1116	CP	12	5.83	7.33	190.6	Sewer Drainage Basin #1	Yes		3	2	3	6	5	4.50	1963	57	18	5	3227	3	3	13.5
1576	1119	CP	12	7.66	5.83	285.3	Sewer Drainage Basin #1	Yes		3	2	3	6	5	4.50	1963	57	18	5	312C	3	3	13.5
3310	3161	CP	8	20.7	27.25	358.5	Sewer Drainage Basin #3	Yes		2	6	3	6	1	4.50	1969	51	24	4	3300	3	3	13.5
2374	2372	PVC	10	17.08	22	285.3	Sewer Drainage Basin #2	No		3	5	4	1	1	2.25	1941	79	-4	6		0	6	13.5
2084	2083	CP	10	8.66	9.25	531.0	Sewer Drainage Basin #2	Yes		3	2	4	6	1	4.45	1941	79	-4	6	3326	3	3	13.4
2089	2088	CP	8	20.92	13.58	286.8	Sewer Drainage Basin #2	Yes		2	5	3	6	1	4.40	1941	79	-4	6	2B00	3	3	13.2
2090	2089	CP	8	6.83	19.83	226.4	Sewer Drainage Basin #2	Yes		2	5	3	6	1	4.40	1941	79	-4	6	3416	3	3	13.2
3033	3032	CP	12	10.5	11.5	350.3	Sewer Drainage Basin #3	Yes		3	3	3	6	1	4.40	1969	51	24	4	3200	3	3	13.2
3182	3181	CP	8	11.58	6.83	427.4	Sewer Drainage Basin #3	Yes		2	3	4	6	2	4.40	1969	51	24	4	3200	3	3	13.2
3181	3137	CP	8	6.83	0	351.5	Sewer Drainage Basin #3	Yes		2	2	4	6	4	4.40	1969	51	24	4	3200	3	3	13.2
3312	3311	CP	8	11.5	19.5	254.7	Sewer Drainage Basin #3	Yes		2	5	3	6	1	4.40	1969	51	24	4	2A00	3	3	13.2
6008	6007	PVC	6	7.75	10	186.7	Sewer Drainage Basin #6	Yes		1	3	5	6	1	4.30	1988	32	43	3		0	3	12.9
2077	2075	CP	8	9.33	8.92	405.0	Sewer Drainage Basin #2	Yes		2	2	4	6	1	4.25	1941	79	-4	6	3125	3	3	12.8
2070	2069	CP	8	9.5	8.58	330.9	Sewer Drainage Basin #2	Yes		2	2	4	6	1	4.25	1941	79	-4	6	311A	3	3	12.8
3373	3372	CP	8	8.25	10.25	263.8	Sewer Drainage Basin #3	Yes		2	3	3	6	1	4.20	1969	51	24	4	2712	3	3	12.6
2124	2123	CP	8	8.67	11.92	213.2	Sewer Drainage Basin #2	Yes		2	3	3	6	1	4.20	1941	79	-4	6	2A00	3	3	12.6
2086	2085	CP	8	12.83	13.83	44.4	Sewer Drainage Basin #2	Yes		2	3	3	6	1	4.20	1941	79	-4	6	2700	3	3	12.6
2108	2314	CP	8	10.33	5.75	206.3	Sewer Drainage Basin #2	Yes		2	3	3	6	1	4.20	1941	79	-4	6	2B00	3	3	12.6
2110	2109	CP	8	9.25	10	330.7	Sewer Drainage Basin #2	Yes		2	3	3	6	1	4.20	1941	79	-4	6	2112	3	3	12.6
3320	3319	CP	8	9.42	10	235.8	Sewer Drainage Basin #3	Yes		2	3	3	6	1	4.20	1969	51	24	4	2D00	3	3	12.6
3316	3315	CP	8	12.92	12.25	288.0	Sewer Drainage Basin #3	Yes		2	3	3	6	1	4.20	1969	51	24	4	2C00	3	3	12.6
3317	3316	CP	8	10.92	12.92	231.0	Sewer Drainage Basin #3	Yes		2	3	3	6	1	4.20	1969	51	24	4	2B00	3	3	12.6
3318	3317	CP	8	13	10.92	93.3	Sewer Drainage Basin #3	Yes		2	3	3	6	1	4.20	1969	51	24	4	2A00	3	3	12.6
3319	3318	CP	8	10	13	227.9	Sewer Drainage Basin #3	Yes		2	3	3	6	1	4.20	1968	52	23	5	2.00E+00	3.00E+00	3	12.6
2107	2200	CP	8	8.92	8.52	272.6	Sewer Drainage Basin #2	Yes		2	2	3	6	1	4.10	1941	79	-4	6	3300	3	3	12.3
2200	2106	CP	8	8.52	9.58	161.3	Sewer Drainage Basin #2	Yes		2	2	3	6	1	4.10	1941	79	-4	6	3400	3	3	12.3
2116	2115	CP	8	6.92	7.33	35.2	Sewer Drainage Basin #2	Yes		2	2	3	6	1	4.10	1941	79	-4	6	3122	3	3	12.3
2078	2077	CP	8	8.33	9.33	398.8	Sewer Drainage Basin #2	Yes		2	2	3	6	1	4.10	1941	79	-4	6	332E	3	3	12.3
2131	2907	CP	8	9.75	9.25	397.2	Sewer Drainage Basin #2	Yes		2	2	3	6	1	4.10	1941	79	-4	6	3121	3	3	12.3
6015	6013	CP	15	3.25	4	70.1	Sewer Drainage Basin #6	Yes		4	1	1	6	1	4.10	1988	32	43	3		0	3	12.3
1032	1031	CP	18	9.92	9.3	313.1	Sewer Drainage Basin #1	Yes		1	2	4	6	1	4.05	1963	57	18	5	3200	3	3	12.2
1034	1033	CP	12	5.5	10	121.6	Sewer Drainage Basin #1	Yes		1	3												

UNITID	UNITID2	MATERIAL	DIAMETER	UP DEPTH	DOWN DEPTH	PIPE LENGTH	Drainage Basin	Backbone Pipe	Quarterly Maintenance	Pipe Diameter COF	Pipe Depth COF	Road Type COF	Seismic Backbone COF	Impact on Water Bodies COF	Weighted COF	Estimated Install Year	Estimated Pipe Age	Estimated Remaining Useful Life	LOF Based on Remaining Useful Life	PACP Quick Score (Overall)	PACP Based LOF (Rounded)	Final LOF	Risk
6013	6012	CP	8	4	4.75	73.8	Sewer Drainage Basin #6	Yes		2	1	1	6	1	3.70	1988	32	43	3		0	3	11.1
2024	2002	VCP	8	9.58	13.66	256.6	Sewer Drainage Basin #2	No		2	3	4	1	1	1.85	1941	79	-4	6		0	6	11.1
2136	2337	VCP	8	4.33	11.25	62.9	Sewer Drainage Basin #2	No		2	3	4	1	1	1.85	1941	79	-4	6		0	6	11.1
2336-CO	2342	VCP	8	0	11.5	102.9	Sewer Drainage Basin #2	No		2	3	4	1	1	1.85	1941	79	-4	6		0	6	11.1
6009	6008	PVC	6	4	7.75	171.7	Sewer Drainage Basin #6	Yes		1	2	1	6	1	3.60	1988	32	43	3		0	3	10.8
1213	1212	CP	8	16	15	413.4	Sewer Drainage Basin #1	No	Flushing Lines	2	4	3	1	1	1.80	1963	57	18	5		0	6	10.8
1181	1180	CP	10	5	5.33	188.6	Sewer Drainage Basin #1	No		3	1	6	1	1	2.15	1963	57	18	5	5100	5	5	10.8
1357	1059	CP	10	11.66	15.25	282.4	Sewer Drainage Basin #1	No		3	4	4	1	1	2.15	1963	57	18	5		0	5	10.8
1201	1200	CP	10	12.83	15.25	239.4	Sewer Drainage Basin #1	No		3	4	4	1	1	2.15	1963	57	18	5		0	5	10.8
6011	6009	PVC	6	4	4	182.4	Sewer Drainage Basin #6	Yes		1	1	1	6	1	3.50	1988	32	43	3		0	3	10.5
2927	2217	PE	8	7.33	8.25	266.0	Sewer Drainage Basin #2	No		2	2	4	1	1	1.75	1941	79	-4	6		0	6	10.5
6012	6009	PVC	6	4.75	4	97.2	Sewer Drainage Basin #6	Yes		1	1	1	6	1	3.50	1988	32	43	3		0	3	10.5
2237	2927	PE	8	9.17	7.33	143.3	Sewer Drainage Basin #2	No		2	2	4	1	1	1.75	1941	79	-4	6		0	6	10.5
2261	2226	CP	10	6.83	13.25	356.7	Sewer Drainage Basin #2	No		3	3	4	1	1	2.05	1941	79	-4	6	512C	5	5	10.3
1193	1358	CP	10	11.3	10.85	55.3	Sewer Drainage Basin #1	No		3	3	4	1	1	2.05	1963	57	18	5		0	5	10.3
1358	1357	CP	10	10.85	11.67	244.8	Sewer Drainage Basin #1	No		3	3	4	1	1	2.05	1963	57	18	5		0	5	10.3
1919	1193	CP	10	13.17	11.17	283.9	Sewer Drainage Basin #1	No		3	3	4	1	1	2.05	1963	57	18	5		0	5	10.3
1312	1054	CP	8	18.25	19.17	545.1	Sewer Drainage Basin #1	No		2	5	4	1	1	2.05	1963	57	18	5		0	5	10.3
1182	1181	CP	8	6.58	5	389.7	Sewer Drainage Basin #1	No		2	2	6	1	1	2.05	1963	57	18	5	512C	5	5	10.3
1540	1318	PVC	8	4.8	10.4	241.3	Sewer Drainage Basin #1	No	Flushing Lines	2	3	3	1	1	1.70	1963	57	18	5		0	6	10.2
2007	2006	CP	18	2.58	7.58	172.0	Sewer Drainage Basin #2	Yes		4	2	5	6	6	5.05	1941	79	-4	6	2100	2	2	10.1
5026-CO	5025	XXX	8	9.75	9.33	180.7	Sewer Drainage Basin #5	No		6	2	2	1	6	2.50	1973	47	28	4		0	4	10.0
3827	3824	CP	8	10.67	13.17	323.1	Sewer Drainage Basin #3	No		2	3	5	1	1	2.00	1975	45	30	4	5135	5	5	10.0
1087	1086	CP	10	11.41	11.33	219.6	Sewer Drainage Basin #1	No	Root-X	3	3	2	1	6	2.00	1963	57	18	5	4B2A	5	5	10.0
1200	1199	CP	10	15.25	9	234.6	Sewer Drainage Basin #1	No		3	4	3	1	1	2.00	1963	57	18	5		0	5	10.0
5036	5016	CP	8	12.33	11	503.2	Sewer Drainage Basin #5	No		6	3	3	1	1	2.50	1973	47	28	4		0	4	10.0
SV1007	6051WW	XXX	0	0	0	8.7	Sewer Drainage Basin #1B	No		6	1	3	1	5	2.50	1972	48	27	4		0	4	10.0
1133	1996	CP	6	5.25	5.85	128.3	Sewer Drainage Basin #1	No		3	1	5	1	1	2.00	1900	120	-45	6	5141	5	5	10.0
1929	1928	PVC	6	7.71	5.71	0.0	Sewer Drainage Basin #1	No		4	2	3	1	1	2.00	1963	57	18	5		0	5	10.0
BOL2189	2189	CP	8	0	0	73.8	Sewer Drainage Basin #2	No		2	1	4	1	1	1.65	1941	79	-4	6		0	6	9.9
3469	3468	CP	8	12.5	10.8	149.0	Sewer Drainage Basin #3	No		2	3	3	1	6	1.95	1969	51	24	4	5121	5	5	9.8
2228	2227	CP	10	7.33	12.58	463.3	Sewer Drainage Basin #2	No	Root-X	3	3	3	1	2	1.95	1941	79	-4	6	512J	5	5	9.8
2263	2262	CP	8	7	14.5	349.3	Sewer Drainage Basin #2	No		2	4	4	1	1	1.95	1941	79	-4	6	5142	5	5	9.8
1341	1056	CP	8	10.5	15.16	313.6	Sewer Drainage Basin #1	No		2	4	4	1	1	1.95	1963	57	18	5		0	5	9.8
1039	1058	CP	8	11.58	15.67	97.9	Sewer Drainage Basin #1	No		2	4	4	1	1	1.95	1963	57	18	5		0	5	9.8
1361	1920	CP	8	14.25	12.17	199.0	Sewer Drainage Basin #1	No		2	4	4	1	1	1.95	1963	57	18	5		0	5	9.8
1362	1361	CP	8	13.17	14.25	235.7	Sewer Drainage Basin #1	No		2	4	4	1	1	1.95	1963	57	18	5		0	5	9.8
1079	1087	CP	10	9.92	11.41	235.2	Sewer Drainage Basin #1	No		3	3	2	1	5	1.95	1963	57	18	5		0	5	9.8
1269	1268	CP	8	11	16.33	440.3	Sewer Drainage Basin #1	No		2	4	4	1	1	1.95	1963	57	18	5		0	5	9.8
1908	1274	CP	8	10.16	17.33	361.3	Sewer Drainage Basin #1	No		2	4	4	1	1	1.95	1963	57	18	5		0	5	9.8
1268	1267	CP	8	16.33	16.5	71.0	Sewer Drainage Basin #1	No		2	4	4	1	1	1.95	1963	57	18	5		0	5	9.8
1274	1267	CP	8	17.33	16.5	332.6	Sewer Drainage Basin #1	No		2	4	4	1	1	1.95	1963	57	18	5		0	5	9.8
1997	1171	PVC	10	0	0	26.0	Sewer Drainage Basin #1	No		2	1	6	1	1	1.95	1963	57	18	5		0	5	9.8
1241	1240	CP	8	5.67	9.75	252.8	Sewer Drainage Basin #1	No	Flushing Lines	2	2	3	1	1	1.60	1963	57	18	5		0	6	9.6
2902	2327	CP	8	9	9.08	342.6	Sewer Drainage Basin #2	No		2	2	3	1	1	1.60	1941	79	-4	6	553B	6	6	9.6
1295	1294	CP	8	8.17	9.25	297.7	Sewer Drainage Basin #1	No	Flushing Lines	2	2	3	1	1	1.60	1963	57	18	5		0	6	9.6
1147	1146	CP	8	7	6.17	578.1	Sewer Drainage Basin #1	No		2	2	3	1	1	1.60	1963	57	18	5	5P43	6	6	9.6
1148	1147	CP	8	5.43	7	244.9	Sewer Drainage Basin #1	No		2	2	3	1	1	1.60	1963	57	18	5	5H38	6	6	9.6
1273	1257	CP	8	6.11	18.4	179.9	Sewer Drainage Basin #1	No		2	5	3	1	1	1.90	1963	57	18	5		0	5	9.5
2229	2280	CP	10	10.58	7.25	217.6	Sewer Drainage Basin #2	No		3	3	3	1	1	1.90	1941	79	-4	6	5133	5	5	9.5
2258	2257	CP	10	12.67	6.42	350.0	Sewer Drainage Basin #2	No		3	3	3	1	1	1.90	1941	79	-4	6	512L	5	5	9.5
2185	2150	CP	8	7.33	8.3	298.1	Sewer Drainage Basin #2	No		2	2	5	1	1	1.90	1941	79	-4	6	5131	5	5	9.5
2153	2334	CP	8	6.33	6.83	164.9	Sewer Drainage Basin #2	No		2	2	5	1	1	1.90	1941	79	-4	6	4A2E	5	5	9.5
3086	3085	CP	8	11.5	5	244.4	Sewer Drainage Basin #3	No		2	3	4	1	2	1.90	1969	51	24	4	5100	5	5	9.5
1313	1312	CP	8	17.5	18.3	51.1	Sewer Drainage Basin #1	No		2	5	3	1	1	1.90	1963	57	18	5		0	5	9.5
1286	1257	CP	8	9	18.4	392.9	Sewer Drainage Basin #1	No		2	5	3	1	1	1.90	1963	57	18	5		0	5	9.5
1090	1089	CP	10	9.33	10.33	267.0	Sewer Drainage Basin #1	No		3	3	3	1	1	1.90	1963	57	18	5		0	5	9.5
3514	3030	CP	8	10	11.25	339.2	Sewer Drainage Basin #3	No	Jetting Lines	2	3	3	1	5	1.90	1969	51	24	4	5231	5	5	9.5
1199	1198	CP	10	12.66	8.42	245.5	Sewer Drainage Basin #1	No		3	3	3	1	1	1.90	1963	57	18	5		0	5	9.5
1561	1562	PVC	8	15.5	18.08	252.7	Sewer Drainage Basin #1	No		2	5	3	1	1	1.90	1963	57	18	5		0	5	9.5
1320	1312	CP	8	15	18.3	178.7	Sewer Drainage Basin #1	No		2	5	3	1	1	1.90	1963	57	18	5		0	5	9.5
1928	1395	CP	8	0	5.8	98.8	Sewer Drainage Basin #1	No		4	1	3	1	1	1.90	1963	57	18	5		0	5	9.5
2020	2019	CP	10	10.17	12.25	314.6	Sewer Drainage Basin #2	Yes		3	3	5	6	1	4.70	1941	79	-4	6	2100	2	2	9.4
1031	1030	CP	20	9.3	9.66	367.8	Sewer Drainage Basin #1	No		5	2	4	1	1	2.35	1963	57	18	5	3C00	4	4	9.4
3035	3932	PVC	12	10.6	11.28	85.6	Sewer Drainage Basin #3	Yes		3	3	3	6	6	4.65	1969	51	24	4	2100	2	2	9.3
1215	1214	CP	8	13.41	12.5	301.7	Sewer Drainage Basin #1	No		2	3	3	1	4	1.85	1963	57	18	5		0	5	9.3
1226	1225	CP	8	11	13	234.5	Sewer Drainage Basin #1	No		2	3	4	1	1	1.85	1963	57	18	5		0	5	9.3
1202	1201	CP	8	8.17	12.83	103.1	Sewer Drainage Basin #1	No		2	3	4	1	1	1.85	1963	57	18	5		0	5	9.3



UNITID	UNITID2	MATERIAL	DIAMETER	UP DEPTH	DOWN DEPTH	PIPE LENGTH	Drainage Basin	Backbone Pipe	Quarterly Maintenance	Pipe Diameter COF	Pipe Depth COF	Road Type COF	Seismic Backbone COF	Impact on Water Bodies COF	Weighted COF	Estimated Install Year	Estimated Pipe Age	Estimated Remaining Useful Life	LOF Based on Remaining Useful Life	PACP Quick Score (Overall)	PACP Based LOF (Rounded)	Final LOF	Risk
1293	1292	CP	8	12.25	11.83	301.5	Sewer Drainage Basin #1	No		2	3	4	1	1	1.85	1963	57	18	5		0	5	9.3
3065	3064	CP	8	5.33	7.17	395.3	Sewer Drainage Basin #3	No		2	2	3	1	6	1.85	1969	51	24	4	5341	5	5	9.3
2071	2070	CP	8	12.5	9.5	444.5	Sewer Drainage Basin #2	No		2	3	4	1	1	1.85	1941	79	-4	6	512K	5	5	9.3
1371	1370	CP	8	9.75	12.42	279.1	Sewer Drainage Basin #1	No		2	3	4	1	1	1.85	1963	57	18	5		0	5	9.3
1214	1213	CP	8	6.5	13.41	137.1	Sewer Drainage Basin #1	No		2	3	3	1	4	1.85	1963	57	18	5		0	5	9.3
1297	1045	CP	8	8.17	11.25	355.7	Sewer Drainage Basin #1	No		2	3	4	1	1	1.85	1963	57	18	5		0	5	9.3
1227	1226	CP	8	10	8.25	281.2	Sewer Drainage Basin #1	No		2	3	4	1	1	1.85	1963	57	18	5		0	5	9.3
1235	1226	CP	8	10	11	242.1	Sewer Drainage Basin #1	No		2	3	4	1	1	1.85	1963	57	18	5	5241	5	5	9.3
1921	1359	CP	8	8.5	11.42	115.0	Sewer Drainage Basin #1	No		2	3	4	1	1	1.85	1963	57	18	5		0	5	9.3
1991	1012	CP	24	18.66	21.33	50.0	Sewer Drainage Basin #1	No		2	5	1	1	6	1.85	1963	57	18	5		0	5	9.3
3183	3182	CP	8	11.17	11.58	440.6	Sewer Drainage Basin #3	Yes		2	3	4	6	6	4.60	1969	51	24	4	2500	2	2	9.2
2219	2900	PE	12	13	8.92	386.3	Sewer Drainage Basin #2	Yes		2	3	4	6	6	4.60	2015	5	70	1	2100	2	2	9.2
3166	3165	CP	8	15.2	14.67	176.7	Sewer Drainage Basin #3	Yes		2	4	5	6	1	4.60	1969	51	24	4	2500	2	2	9.2
3164	3163	CP	8	15	9.11	441.5	Sewer Drainage Basin #3	Yes		2	4	5	6	1	4.60	1969	51	24	4	2100	2	2	9.2
3313	3312	CP	8	15.75	11.5	263.4	Sewer Drainage Basin #3	Yes		2	4	5	6	1	4.60	1969	51	24	4	2300	2	2	9.2
2168	2140	PE	8	9.91	10.33	201.0	Sewer Drainage Basin #2	Yes		2	3	5	6	2	4.55	2013	7	68	1	2100	2	2	9.1
1086	1085	CP	8	11.8	4.9	147.8	Sewer Drainage Basin #1	No		2	3	2	1	6	1.80	1963	57	18	5		0	5	9.0
1272-CO	1266	XXX	8	0	14.8	149.0	Sewer Drainage Basin #1	No		2	4	3	1	1	1.80	1963	57	18	5		0	5	9.0
1198	1197	CP	10	8.42	9.75	238.1	Sewer Drainage Basin #1	No		3	2	3	1	1	1.80	1963	57	18	5		0	5	9.0
1229	1228	CP	8	16	15.83	41.4	Sewer Drainage Basin #1	No		2	4	3	1	1	1.80	1963	57	18	5		0	5	9.0
1228	1223	CP	8	15.83	14.33	123.1	Sewer Drainage Basin #1	No		2	4	3	1	1	1.80	1963	57	18	5		0	5	9.0
1236	1199	CP	8	15.47	12.66	350.2	Sewer Drainage Basin #1	No		2	4	3	1	1	1.80	1963	57	18	5		0	5	9.0
1206	1205	CP	8	15.75	17	245.7	Sewer Drainage Basin #1	No		2	4	3	1	1	1.80	1963	57	18	5		0	5	9.0
2041	2040	CP	8	7.33	7.75	286.6	Sewer Drainage Basin #2	No		2	2	3	1	5	1.80	1941	79	-4	6	5241	5	5	9.0
1207	1206	CP	8	10.42	15.75	419.6	Sewer Drainage Basin #1	No		2	4	3	1	1	1.80	1963	57	18	5		0	5	9.0
1208	1207	CP	8	10.67	15.75	374.3	Sewer Drainage Basin #1	No		2	4	3	1	1	1.80	1963	57	18	5		0	5	9.0
2130	2020	CP	8	8.92	10.17	255.9	Sewer Drainage Basin #2	Yes		2	3	5	6	1	4.50	1941	79	-4	6	2300	2	2	9.0
3105	3082	CP	8	6.92	7	396.5	Sewer Drainage Basin #3	No		2	2	4	1	2	1.80	1969	51	24	4	5100	5	5	9.0
1492	1491	CP	8	6.7	6.2	349.6	Sewer Drainage Basin #1B	No		2	2	4	1	2	1.80	1968	52	23	5		0	5	9.0
1260	1259	CP	8	15	9.1	303.6	Sewer Drainage Basin #1	No		2	4	3	1	1	1.80	1963	57	18	5		0	5	9.0
1314	1313	CP	8	15.8	17.5	168.5	Sewer Drainage Basin #1	No		2	4	3	1	1	1.80	1963	57	18	5		0	5	9.0
1315	1314	CP	8	11.2	15.8	494.2	Sewer Drainage Basin #1	No		2	4	3	1	1	1.80	1963	57	18	5		0	5	9.0
1263	1262	CP	8	14	10.33	363.6	Sewer Drainage Basin #1	No		2	4	3	1	1	1.80	1963	57	18	5		0	5	9.0
1264	1263	CP	8	10.33	14	184.9	Sewer Drainage Basin #1	No		2	4	3	1	1	1.80	1963	57	18	5		0	5	9.0
3061	3060	CP	10	15.6	8	356.3	Sewer Drainage Basin #3	No		3	4	3	1	6	2.25	1969	51	24	4	4100	4	4	9.0
1541	1504	PVC	8	14	5.8	399.3	Sewer Drainage Basin #1	No		2	4	3	1	1	1.80	1963	57	18	5		0	5	9.0
1266	1904	CP	8	14.83	8.5	199.7	Sewer Drainage Basin #1	No		2	4	3	1	1	1.80	1963	57	18	5		0	5	9.0
1335	1329	CP	8	10.25	14	405.3	Sewer Drainage Basin #1	No		2	4	3	1	1	1.80	1963	57	18	5		0	5	9.0
1205	1204	CP	8	17	12.83	328.2	Sewer Drainage Basin #1	No		2	4	3	1	1	1.80	1963	57	18	5		0	5	9.0
1223	1222	CP	8	14.33	10.25	220.3	Sewer Drainage Basin #1	No		2	4	3	1	1	1.80	1963	57	18	5		0	5	9.0
3048	3047	CP	8	14.42	16	434.6	Sewer Drainage Basin #3	No		2	4	3	1	1	1.80	1969	51	24	4	512F	5	5	9.0
1376	1067	CP	8	11.3	14.75	269.3	Sewer Drainage Basin #1	No		2	4	3	1	1	1.80	1963	57	18	5		0	5	9.0
1384	1067	CP	8	10.7	15	238.1	Sewer Drainage Basin #1	No		2	4	3	1	1	1.80	1963	57	18	5		0	5	9.0
1169	1168	CP	10	8	8	119.5	Sewer Drainage Basin #1	No		3	2	6	1	1	2.25	1963	57	18	5	4131	4	4	9.0
1321	1320	CP	8	13.8	15	419.4	Sewer Drainage Basin #1	No		2	4	3	1	1	1.80	1963	57	18	5		0	5	9.0
1406	1405	CP	8	10.6	10.2	109.7	Sewer Drainage Basin #1	No		2	3	3	1	3	1.80	1963	57	18	5		0	5	9.0
1407-CO	1406	CP	8	0	10.6	190.6	Sewer Drainage Basin #1	No		2	3	3	1	3	1.80	1963	57	18	5		0	5	9.0
4031	CCMH053	CP	8	10	0	58.1	Sewer Drainage Basin #4	No		2	3	5	1	6	2.25	1974	46	29	4		0	4	9.0
1233	1236	PVC	8	14.25	11.5	227.7	Sewer Drainage Basin #1	No		2	4	3	1	1	1.80	1963	57	18	5		0	5	9.0
1285-CO	1195	XXX	0	0	0	87.2	Sewer Drainage Basin #1	No		2	1	3	1	1	1.50	1900	120	-45	6		0	6	9.0
3156	3157	CP	8	20.5	17.67	210.5	Sewer Drainage Basin #3	Yes		2	5	3	6	2	4.40	1969	51	24	4	2200	2	2	8.8
3184	3183	CP	8	13.58	11.17	391.8	Sewer Drainage Basin #3	Yes		2	3	4	6	2	4.40	1969	51	24	4	2400	2	2	8.8
3311	3310	CP	8	19.6	20.7	296.2	Sewer Drainage Basin #3	Yes		2	5	3	6	1	4.40	1969	51	24	4	2400	2	2	8.8
SV1008	6051WW	CP	8	12.5	0	26.0	Sewer Drainage Basin #1B	No		2	3	5	1	5	2.20	1972	48	27	4		0	4	8.8
1237	1201	CP	8	0	9.1	346.1	Sewer Drainage Basin #1	No		2	2	4	1	1	1.75	1963	57	18	5		0	5	8.8
2264	2263	CP	8	7	6.75	362.2	Sewer Drainage Basin #2	No		2	2	4	1	1	1.75	1941	79	-4	6	5131	5	5	8.8
1493	1492	CP	8	6.4	6.7	66.7	Sewer Drainage Basin #1B	No		2	2	4	1	1	1.75	1968	52	23	5		0	5	8.8
1494	1493	CP	8	5.9	6.4	316.7	Sewer Drainage Basin #1B	No		2	2	4	1	1	1.75	1968	52	23	5		0	5	8.8
1166	1029	CP	8	8	9.33	402.5	Sewer Drainage Basin #1	No		2	2	4	1	1	1.75	1963	57	18	5	5231	5	5	8.8
1267	1905	CP	8	9.66	9.66	398.2	Sewer Drainage Basin #1	No		2	2	4	1	1	1.75	1963	57	18	5		0	5	8.8
1203	1202	CP	8	8.66	8.17	253.4	Sewer Drainage Basin #1	No		2	2	4	1	1	1.75	1963	57	18	5		0	5	8.8
2091	2080	CP	8	8	8.25	400.0	Sewer Drainage Basin #2	No		2	2	4	1	1	1.75	1941	79	-4	6	5241	5	5	8.8
1184-CO	1179	XXX	0	0	0	138.0	Sewer Drainage Basin #1	No		1	1	6	1	1	1.75	1963	57	18	5		0	5	8.8
1408	1405	CP	8	12	10.2	233.4	Sewer Drainage Basin #1	No		2	3	3	1	2	1.75	1963	57	18	5		0	5	8.8
1281	1274	CP	8	9.43	9.33	360.2	Sewer Drainage Basin #1	No		2	2	4	1	1	1.75	1963	57	18	5		0	5	8.8
3526	3008	CP	8	14	17	83.8	Sewer Drainage Basin #3	No		2	4	1	1	6	1.75	1969	51	24	4	5421	5	5	8.8
1124	1123	PVC	10	4.58	4.58	287.1	Sewer Drainage Basin #1	Yes		3	1	3	6	4	4.35	1963	57	18	5	2200	2	2	8.7
3080	3939	CP	10	0	10.42	373.2	Sewer Drainage Basin #3	No		3	3	4	1	3	2.15	1969	51	24	4		0	4	8.6
1416	1417	CP	8	6.2	13.1	236.2	Sewer Drainage																



UNITID	UNITID2	MATERIAL	DIAMETER	UP DEPTH	DOWN DEPTH	PIPE LENGTH	Drainage Basin	Backbone Pipe	Quarterly Maintenance	Pipe Diameter COF	Pipe Depth COF	Road Type COF	Seismic Backbone COF	Impact on Water Bodies COF	Weighted COF	Estimated Install Year	Estimated Pipe Age	Estimated Remaining Useful Life	LOF Based on Remaining Useful Life	PACP Quick Score (Overall)	PACP Based LOF (Rounded)	Final LOF	Risk
1216	1222	CP	8	8.25	11.8	281.0	Sewer Drainage Basin #1	No		2	3	3	1	1	1.70	1963	57	18	5		0	5	8.5
1231	1230	CP	8	5.58	10.5	250.0	Sewer Drainage Basin #1	No		2	3	3	1	1	1.70	1963	57	18	5		0	5	8.5
1234	1225	CP	8	11	8.1	240.5	Sewer Drainage Basin #1	No		2	3	3	1	1	1.70	1963	57	18	5		0	5	8.5
1240	1239	CP	8	9.75	11.33	350.9	Sewer Drainage Basin #1	No		2	3	3	1	1	1.70	1963	57	18	5		0	5	8.5
1245	1244	CP	8	10.33	10.33	104.2	Sewer Drainage Basin #1	No		2	3	3	1	1	1.70	1963	57	18	5		0	5	8.5
1289	1258	CP	8	9.7	12.4	278.1	Sewer Drainage Basin #1	No		2	3	3	1	1	1.70	1963	57	18	5		0	5	8.5
1339	1338	CP	8	11.4	11.4	268.4	Sewer Drainage Basin #1	No		2	3	3	1	1	1.70	1963	57	18	5		0	5	8.5
1352	1596	CP	8	8	10.83	222.8	Sewer Drainage Basin #1	No		2	3	3	1	1	1.70	1963	57	18	5		0	5	8.5
2331	2266	CP	8	8.7	12.25	454.1	Sewer Drainage Basin #2	No		2	3	3	1	1	1.70	1941	79	-4	6	5132	5	5	8.5
1194-CO	1393	CP	8	0	11.17	58.4	Sewer Drainage Basin #1	No		2	3	3	1	1	1.70	1963	57	18	5		0	5	8.5
1278	1277	CP	8	12.33	11.5	210.5	Sewer Drainage Basin #1	No		2	3	3	1	1	1.70	1963	57	18	5		0	5	8.5
2075	2070	CP	8	8.92	9.5	270.2	Sewer Drainage Basin #2	Yes	Root-X	2	2	4	6	1	4.25	1941	79	-4	6	1F00	2	2	8.5
1338	1337	CP	8	11.4	11.8	190.9	Sewer Drainage Basin #1	No		2	3	3	1	1	1.70	1963	57	18	5		0	5	8.5
1334	1328	CP	8	10.33	10.5	345.8	Sewer Drainage Basin #1	No		2	3	3	1	1	1.70	1963	57	18	5		0	5	8.5
1342	1341	CP	8	11	10.41	310.4	Sewer Drainage Basin #1	No		2	3	3	1	1	1.70	1963	57	18	5		0	5	8.5
1343	1342	CP	8	10.66	11	281.3	Sewer Drainage Basin #1	No		2	3	3	1	1	1.70	1963	57	18	5		0	5	8.5
1373	1060	CP	8	8.17	10.75	169.5	Sewer Drainage Basin #1	No		2	3	3	1	1	1.70	1963	57	18	5		0	5	8.5
1374	1060	CP	8	9.5	10.43	260.5	Sewer Drainage Basin #1	No		2	3	3	1	1	1.70	1963	57	18	5		0	5	8.5
1365	1366	CP	8	10	10.7	231.8	Sewer Drainage Basin #1	No		2	3	3	1	1	1.70	1963	57	18	5		0	5	8.5
1366	1062	CP	8	10.7	13.83	51.8	Sewer Drainage Basin #1	No		2	3	3	1	1	1.70	1963	57	18	5		0	5	8.5
1378	1377	CP	8	10.5	12.8	205.3	Sewer Drainage Basin #1	No		2	3	3	1	1	1.70	1963	57	18	5		0	5	8.5
1379	1378	CP	8	8	10.5	171.0	Sewer Drainage Basin #1	No		2	3	3	1	1	1.70	1963	57	18	5		0	5	8.5
1382	1377	CP	8	9.9	12.8	173.8	Sewer Drainage Basin #1	No		2	3	3	1	1	1.70	1963	57	18	5		0	5	8.5
1390	1069	CP	8	11	11.7	36.9	Sewer Drainage Basin #1	No		2	3	3	1	1	1.70	1963	57	18	5		0	5	8.5
1391	1390	CP	8	12.5	11	438.9	Sewer Drainage Basin #1	No		2	3	3	1	1	1.70	1963	57	18	5		0	5	8.5
1392	1391	CP	8	11.67	12.58	72.7	Sewer Drainage Basin #1	No		2	3	3	1	1	1.70	1963	57	18	5		0	5	8.5
1554-CO	1392	CP	8	0	11.67	110.0	Sewer Drainage Basin #1	No		2	3	3	1	1	1.70	1963	57	18	5		0	5	8.5
1385	1384	CP	8	10.2	10.7	157.4	Sewer Drainage Basin #1	No		2	3	3	1	1	1.70	1963	57	18	5		0	5	8.5
1386	1385	CP	8	10.2	10.2	223.4	Sewer Drainage Basin #1	No		2	3	3	1	1	1.70	1963	57	18	5		0	5	8.5
3461	3460	CP	8	7.67	10.42	208.3	Sewer Drainage Basin #3	No		2	3	3	1	1	1.70	1969	51	24	4	5132	5	5	8.5
3462	3461	CP	8	10.67	7.67	75.2	Sewer Drainage Basin #3	No		2	3	3	1	1	1.70	1969	51	24	4	5141	5	5	8.5
1354	1353	CP	8	11.4	12.83	183.5	Sewer Drainage Basin #1	No		2	3	3	1	1	1.70	1963	57	18	5		0	5	8.5
1355	1394	CP	8	10.17	10.67	325.3	Sewer Drainage Basin #1	No		2	3	3	1	1	1.70	1963	57	18	5		0	5	8.5
1394	1354	CP	8	10.67	11.4	352.2	Sewer Drainage Basin #1	No		2	3	3	1	1	1.70	1963	57	18	5		0	5	8.5
1259	1258	CP	8	10	12.4	299.6	Sewer Drainage Basin #1	No		2	3	3	1	1	1.70	1963	57	18	5		0	5	8.5
1238	1203	CP	8	10.33	8.33	244.2	Sewer Drainage Basin #1	No		2	3	3	1	1	1.70	1963	57	18	5		0	5	8.5
1239	1238	CP	8	11.33	10.33	222.1	Sewer Drainage Basin #1	No		2	3	3	1	1	1.70	1963	57	18	5		0	5	8.5
1243	1238	CP	8	10.42	10.33	106.2	Sewer Drainage Basin #1	No		2	3	3	1	1	1.70	1963	57	18	5		0	5	8.5
1244	1239	CP	8	10.33	11.33	234.5	Sewer Drainage Basin #1	No		2	3	3	1	1	1.70	1963	57	18	5		0	5	8.5
1248-CO	1244	CP	8	0	10.33	64.3	Sewer Drainage Basin #1	No		2	3	3	1	1	1.70	1963	57	18	5		0	5	8.5
1368	1367	CP	8	11.8	6.5	335.4	Sewer Drainage Basin #1	No		2	3	3	1	1	1.70	1963	57	18	5		0	5	8.5
1322	1321	CP	8	8.9	13.8	452.6	Sewer Drainage Basin #1	No		2	3	3	1	1	1.70	1963	57	18	5		0	5	8.5
1323	1322	CP	8	10.3	8.9	434.6	Sewer Drainage Basin #1	No		2	3	3	1	1	1.70	1963	57	18	5		0	5	8.5
1324	1315	CP	8	9.3	11.2	350.0	Sewer Drainage Basin #1	No		2	3	3	1	1	1.70	1963	57	18	5		0	5	8.5
1294	1293	CP	8	8.25	12.25	348.4	Sewer Drainage Basin #1	No		2	3	3	1	1	1.70	1963	57	18	5		0	5	8.5
1344	1343	CP	8	10.67	12.67	265.2	Sewer Drainage Basin #1	No		2	3	3	1	1	1.70	1963	57	18	5		0	5	8.5
1345	1344	CP	8	4.8	10.7	126.8	Sewer Drainage Basin #1	No		2	3	3	1	1	1.70	1963	57	18	5		0	5	8.5
1351	1344	CP	8	10.7	10.7	364.6	Sewer Drainage Basin #1	No		2	3	3	1	1	1.70	1963	57	18	5		0	5	8.5
1337	1330	CP	8	11.8	10	320.7	Sewer Drainage Basin #1	No		2	3	3	1	1	1.70	1963	57	18	5		0	5	8.5
1348	1342	CP	8	10	11	214.6	Sewer Drainage Basin #1	No		2	3	3	1	1	1.70	1963	57	18	5		0	5	8.5
1349	1348	CP	8	8.91	10	213.3	Sewer Drainage Basin #1	No		2	3	3	1	1	1.70	1963	57	18	5		0	5	8.5
1350	1342	CP	8	8.66	11	212.4	Sewer Drainage Basin #1	No		2	3	3	1	1	1.70	1963	57	18	5		0	5	8.5
4420	4090	CP	8	9.3	10.2	163.9	Sewer Drainage Basin #4	No		2	3	3	1	1	1.70	1974	46	29	4	5212	5	5	8.5
2112	2111	CP	8	8.08	11.33	126.0	Sewer Drainage Basin #2	No		2	3	3	1	1	1.70	1941	79	-4	6	5241	5	5	8.5
3232	3141	CP	8	6.75	7.9	26.6	Sewer Drainage Basin #3	Yes		2	2	4	6	1	4.25	1969	51	24	4	2100	2	2	8.5
1088	1079	CP	10	11.33	9.92	120.5	Sewer Drainage Basin #1	No		3	3	1	1	3	1.70	1963	57	18	5		0	5	8.5
1387	1386	CP	8	7.8	10.2	101.9	Sewer Drainage Basin #1	No		2	3	3	1	1	1.70	1963	57	18	5		0	5	8.5
1076	1075	CP	8	6.08	11.67	231.6	Sewer Drainage Basin #1	No		2	3	3	1	1	1.70	1963	57	18	5		0	5	8.5
1401	1073	CP	8	8.33	13	245.4	Sewer Drainage Basin #1	No		2	3	3	1	1	1.70	1963	57	18	5		0	5	8.5
1261	1253	CP	8	12.5	8.75	401.0	Sewer Drainage Basin #1	No		2	3	3	1	1	1.70	1963	57	18	5		0	5	8.5
1262	1261	CP	8	12.5	8.1	233.7	Sewer Drainage Basin #1	No		2	3	3	1	1	1.70	1963	57	18	5		0	5	8.5
1265	1262	CP	8	7.5	10.42	293.6	Sewer Drainage Basin #1	No		2	3	3	1	1	1.70	1963	57	18	5		0	5	8.5
1317	1316	CP	8	10.3	9.6	298.4	Sewer Drainage Basin #1	No		2	3	3	1	1	1.70	1963	57	18	5		0	5	8.5
1318	1317	CP	8	10.4	10.3	82.9	Sewer Drainage Basin #1	No		2	3	3	1	1	1.70	1963	57	18	5		0	5	8.5
1319	1505	CP	8	10.5	11	186.9	Sewer Drainage Basin #1	No		2	3	3	1	1	1.70	1963	57	18	5		0	5	8.5
2069	2318	CP	8	8.58	7.17	317.0	Sewer Drainage Basin #2	Yes		2	2	4	6	1	4.25	1941	79	-4	6	2100	2	2	8.5
2318	2068	CP	8	7.17	9.33	102.8	Sewer Drainage Basin #2	Yes		2	2	4	6	1	4.25	1941	79	-4	6	2300	2	2	8.5
1393	1391	CP	8	11.42	12.58	255.3	Sewer Drainage Basin #1	No		2	3	3	1	1	1.70	1963	57	18	5		0	5	8.5
1270	1269	CP	8	10.83	11	319.7	Sewer Drainage Basin #1	No		2	3	3	1	1</									

UNITID	UNITID2	MATERIAL	DIAMETER	UP DEPTH	DOWN DEPTH	PIPE LENGTH	Drainage Basin	Backbone Pipe	Quarterly Maintenance	Pipe Diameter COF	Pipe Depth COF	Road Type COF	Seismic Backbone COF	Impact on Water Bodies COF	Weighted COF	Estimated Install Year	Estimated Pipe Age	Estimated Remaining Useful Life	LOF Based on Remaining Useful Life	PACP Quick Score (Overall)	PACP Based LOF (Rounded)	Final LOF	Risk
1277	1276	CP	8	11.5	9.33	380.8	Sewer Drainage Basin #1	No		2	3	3	1	1	1.70	1963	57	18	5		0	5	8.5
1340	1338	CP	8	10.8	11.4	158.9	Sewer Drainage Basin #1	No		2	3	3	1	1	1.70	1963	57	18	5		0	5	8.5
1353	1352	CP	8	12.66	13.67	299.1	Sewer Drainage Basin #1	No		2	3	3	1	1	1.70	1963	57	18	5		0	5	8.5
1356-CO	1353	CP	8	0	10.6	131.3	Sewer Drainage Basin #1	No		2	3	3	1	1	1.70	1963	57	18	5		0	5	8.5
1521	1275	CP	8	11	10.83	47.1	Sewer Drainage Basin #1	No		2	3	3	1	1	1.70	1963	57	18	5		0	5	8.5
1247	1205	CP	8	11.5	10.5	399.5	Sewer Drainage Basin #1	No		2	3	3	1	1	1.70	1963	57	18	5		0	5	8.5
1303	1302	CP	8	10.58	8.58	320.0	Sewer Drainage Basin #1	No		2	3	3	1	1	1.70	1963	57	18	5		0	5	8.5
1304	1303	CP	8	10.33	10.58	177.4	Sewer Drainage Basin #1	No		2	3	3	1	1	1.70	1963	57	18	5		0	5	8.5
1224	1223	CP	8	12.25	12	80.3	Sewer Drainage Basin #1	No		2	3	3	1	1	1.70	1963	57	18	5		0	5	8.5
1225	1224	CP	8	13	10.5	239.0	Sewer Drainage Basin #1	No		2	3	3	1	1	1.70	1963	57	18	5		0	5	8.5
1298	1297	CP	8	9.47	10.17	346.8	Sewer Drainage Basin #1	No		2	3	3	1	1	1.70	1963	57	18	5		0	5	8.5
1299	1298	CP	8	9.47	10.17	332.0	Sewer Drainage Basin #1	No		2	3	3	1	1	1.70	1963	57	18	5		0	5	8.5
1300	1299	CP	8	13.25	9.47	394.4	Sewer Drainage Basin #1	No		2	3	3	1	1	1.70	1963	57	18	5		0	5	8.5
1301	1909	CP	8	9.17	10.47	159.1	Sewer Drainage Basin #1	No		2	3	3	1	1	1.70	1963	57	18	5		0	5	8.5
1909	1300	CP	8	10.47	13.25	273.0	Sewer Drainage Basin #1	No		2	3	3	1	1	1.70	1963	57	18	5		0	5	8.5
1316	1315	CP	8	9.6	10.2	234.2	Sewer Drainage Basin #1	No		2	3	3	1	1	1.70	1963	57	18	5		0	5	8.5
1377	1376	CP	8	12.8	11.3	146.0	Sewer Drainage Basin #1	No		2	3	3	1	1	1.70	1963	57	18	5		0	5	8.5
4915-CO	4914	CP	8	0	6.75	110.8	Sewer Drainage Basin #4	No		2	2	3	1	3	1.70	1974	46	29	4	5141	5	5	8.5
1372	1371	CP	6	6.5	13.63	230.0	Sewer Drainage Basin #1	No		2	3	3	1	1	1.70	1963	57	18	5		0	5	8.5
1375	1064	CP	8	9	11.42	272.4	Sewer Drainage Basin #1	No		2	3	3	1	1	1.70	1963	57	18	5		0	5	8.5
1402	1066	CP	8	9.76	13.83	235.0	Sewer Drainage Basin #1	No		2	3	3	1	1	1.70	1963	57	18	5		0	5	8.5
1403	1402	CP	8	10.1	9.3	143.4	Sewer Drainage Basin #1	No		2	3	3	1	1	1.70	1963	57	18	5		0	5	8.5
1404	1403	CP	8	10	9.3	149.7	Sewer Drainage Basin #1	No		2	3	3	1	1	1.70	1963	57	18	5		0	5	8.5
1405	1404	CP	8	10.2	10	59.1	Sewer Drainage Basin #1	No		2	3	3	1	1	1.70	1963	57	18	5		0	5	8.5
3122	3121	CP	8	10.75	9.17	348.6	Sewer Drainage Basin #3	No		2	3	3	1	1	1.70	1969	51	24	4	5131	5	5	8.5
1553-CO	1392	CP	8	0	11.67	168.5	Sewer Drainage Basin #1	No		2	3	3	1	1	1.70	1963	57	18	5		0	5	8.5
1996	1130	CP	6	5.85	0	150.8	Sewer Drainage Basin #1	No		3	1	3	1	1	1.70	1900	120	-45	6	5123	5	5	8.5
3372	3371	CP	8	10.25	9.75	174.8	Sewer Drainage Basin #3	Yes		2	3	3	6	1	4.20	1969	51	24	4	2200	2	2	8.4
5028	5027	CP	8	10.33	14.33	362.6	Sewer Drainage Basin #5	No		2	4	5	1	1	2.10	1973	47	28	4		0	4	8.4
5027	5002	CP	8	14.33	13.5	359.7	Sewer Drainage Basin #5	No		2	4	5	1	1	2.10	1973	47	28	4		0	4	8.4
5057	5053	CP	8	10	15.6	246.7	Sewer Drainage Basin #5	No		2	4	5	1	1	2.10	1973	47	28	4		0	4	8.4
5900	5053	CP	8	11.33	15.6	276.0	Sewer Drainage Basin #5	No		2	4	5	1	1	2.10	1973	47	28	4		0	4	8.4
5053	5052	CP	8	15.6	0	292.3	Sewer Drainage Basin #5	No		2	4	5	1	1	2.10	1973	47	28	4		0	4	8.4
1409	1410	CP	8	15.41	12.9	349.9	Sewer Drainage Basin #1B	No		2	4	5	1	1	2.10	1972	48	27	4		0	4	8.4
1757	1700	CP	8	16	12	319.0	Sewer Drainage Basin #1B	No		2	4	5	1	1	2.10	1972	48	27	4		0	4	8.4
2337	2336-CO	CP	8	11.25	6	79.2	Sewer Drainage Basin #2	No		2	3	1	1	1	1.40	1941	79	-4	6		0	6	8.4
3029	3028	CP	15	11.17	12.5	378.8	Sewer Drainage Basin #3	Yes		2	3	3	6	1	4.20	1969	51	24	4	2100	2	2	8.4
2126-CO	2124	CP	6	0	8.67	272.0	Sewer Drainage Basin #2	No		1	2	3	1	1	1.40	1941	79	-4	6		0	6	8.4
1495-CO	1494	CP	8	0	5.9	76.1	Sewer Drainage Basin #1B	No		2	1	4	1	1	1.65	1972	48	27	4	5141	5	5	8.3
3171	3170	CP	8	6.17	6.08	176.6	Sewer Drainage Basin #3	No		2	2	3	1	2	1.65	1969	51	24	4	5100	5	5	8.3
1089	1088	CP	10	10.33	11.33	137.8	Sewer Drainage Basin #1	No		3	3	1	1	2	1.65	1963	57	18	5		0	5	8.3
4204	4203	PVC	8	6.5	8.4	147.1	Sewer Drainage Basin #4	No		2	2	3	1	2	1.65	1974	46	29	4	5100	5	5	8.3
1360	1358	PVC	6	4.67	10.5	406.3	Sewer Drainage Basin #1	No		1	3	4	1	1	1.65	1963	57	18	5		0	5	8.3
1186	1185	CP	8	5	5.75	352.4	Sewer Drainage Basin #1	No		2	1	4	1	1	1.65	1963	57	18	5	5131	5	5	8.3
4088	4087	CP	8	8.1	6	266.4	Sewer Drainage Basin #4	No		2	2	3	1	2	1.65	1974	46	29	4	5141	5	5	8.3
PRMH045	1153	PVC	8	5.33	5.5	52.8	Sewer Drainage Basin #1	No		2	1	4	1	1	1.65	1963	57	18	5		0	5	8.3
5039	5038	CP	8	17.7	6.2	99.6	Sewer Drainage Basin #5	No		2	4	3	1	6	2.05	1973	47	28	4		0	4	8.2
1566	1575	PVC	8	9.25	9.5	42.8	Sewer Drainage Basin #1	No		2	2	6	1	1	2.05	1963	57	18	5	3A00	4	4	8.2
2247	2245	CP	8	7.33	9.67	296.2	Sewer Drainage Basin #2	No		2	2	6	1	1	2.05	1941	79	-4	6	412C	4	4	8.2
3062	3061	CP	10	10.9	15.5	423.2	Sewer Drainage Basin #3	No		3	4	3	1	2	2.05	1969	51	24	4	4131	4	4	8.2
5055	5054	CP	8	10	7.9	255.7	Sewer Drainage Basin #5	No		2	3	5	1	1	2.00	1973	47	28	4		0	4	8.0
2062	2016	CP	8	7.5	13.42	332.5	Sewer Drainage Basin #2	No		2	3	5	1	1	2.00	1941	79	-4	6	4132	4	4	8.0
1591	1133	CP	6	4	5.42	234.3	Sewer Drainage Basin #1	No		1	1	5	1	1	1.60	1963	57	18	5	5142	5	5	8.0
5030	5028	CP	8	8	10.33	444.9	Sewer Drainage Basin #5	No		2	3	5	1	1	2.00	1973	47	28	4		0	4	8.0
1452	1410	CP	8	9.3	12.9	391.3	Sewer Drainage Basin #1B	No		2	3	5	1	1	2.00	1972	48	27	4		0	4	8.0
1458	1412	CP	8	11.2	10.75	380.4	Sewer Drainage Basin #1B	No		2	3	5	1	1	2.00	1972	48	27	4		0	4	8.0
1461	1415	CP	8	12.66	5	416.9	Sewer Drainage Basin #1B	No		2	3	5	1	1	2.00	1972	48	27	4		0	4	8.0
1410	1411	CP	8	12.9	10.75	239.0	Sewer Drainage Basin #1B	No		2	3	5	1	1	2.00	1972	48	27	4		0	4	8.0
1411	1525	CP	8	12.5	11	209.2	Sewer Drainage Basin #1B	No		2	3	5	1	1	2.00	1972	48	27	4		0	4	8.0
1412	1413	CP	8	10.5	7.25	257.6	Sewer Drainage Basin #1B	No		2	3	5	1	1	2.00	1972	48	27	4		0	4	8.0
1525	1412	CP	8	11	11.33	52.6	Sewer Drainage Basin #1B	No		2	3	5	1	1	2.00	1972	48	27	4		0	4	8.0
1747	1701	CP	8	12.67	12.2	116.9	Sewer Drainage Basin #1B	No		2	3	5	1	1	2.00	1972	48	27	4		0	4	8.0
1748	1747	CP	8	11.08	12.67	415.3	Sewer Drainage Basin #1B	No		2	3	5	1	1	2.00	1972	48	27	4		0	4	8.0
1750	1748	CP	8	13.67	11.08	329.9	Sewer Drainage Basin #1B	No		2	3	5	1	1	2.00	1972	48	27	4		0	4	8.0
1751	1750	CP	8	13	13.67	91.1	Sewer Drainage Basin #1B	No		2	3	5	1	1	2.00	1972	48	27	4		0	4	8.0
1752	1751	CP	8	13.17	13	210.3	Sewer Drainage Basin #1B	No		2	3	5	1	1	2.00	1972	48	27	4		0	4	8.0
1753	1752	CP	8	12.25	13.17	220.6	Sewer Drainage Basin #1B	No		2	3	5	1	1	2.00	1972	48	27	4		0	4	8.0
3825	3824	CP	8	13.05	13.17	252.4	Sewer Drainage Basin #3	No		2	3	5	1	1	2.00	1969	51	24	4	4123	4	4	8.0
5054	5900	CP	8	7.9	11.33	295.9	Sewer Drainage Basin #5																

UNITID	UNITID2	MATERIAL	DIAMETER	UP DEPTH	DOWN DEPTH	PIPE LENGTH	Drainage Basin	Backbone Pipe	Quarterly Maintenance	Pipe Diameter COF	Pipe Depth COF	Road Type COF	Seismic Backbone COF	Impact on Water Bodies COF	Weighted COF	Estimated Install Year	Estimated Pipe Age	Estimated Remaining Useful Life	LOF Based on Remaining Useful Life	PACP Quick Score (Overall)	PACP Based LOF (Rounded)	Final LOF	Risk
1761	1751	CP	8	0	13	220.9	Sewer Drainage Basin #1B	No		2	3	5	1	1	2.00	1972	48	27	4		0	4	8.0
2213	2022	CP	8	10.75	10.42	231.5	Sewer Drainage Basin #2	No		2	3	5	1	1	2.00	1941	79	-4	6	3800	4	4	8.0
1187	1186	CP	8	6.75	5	319.0	Sewer Drainage Basin #1	No		2	2	3	1	1	1.60	1963	57	18	5		0	5	8.0
1220	1198	CP	8	8.25	8.42	349.7	Sewer Drainage Basin #1	No		2	2	3	1	1	1.60	1963	57	18	5		0	5	8.0
1232	1231	CP	8	8	5.58	161.1	Sewer Drainage Basin #1	No		2	2	3	1	1	1.60	1963	57	18	5		0	5	8.0
1242	1241	CP	8	8.25	5.67	386.2	Sewer Drainage Basin #1	No		2	2	3	1	1	1.60	1963	57	18	5		0	5	8.0
1280	1279	CP	8	7.83	7	109.0	Sewer Drainage Basin #1	No		2	2	3	1	1	1.60	1963	57	18	5		0	5	8.0
1279	1275	CP	8	7	7	255.0	Sewer Drainage Basin #1	No		2	2	3	1	1	1.60	1963	57	18	5		0	5	8.0
3355	3354	CP	8	8.8	8.83	332.4	Sewer Drainage Basin #3	No		2	2	3	1	1	1.60	1969	51	24	4	5100	5	5	8.0
2242	2241	CP	8	7.75	7.42	196.0	Sewer Drainage Basin #2	No		2	2	3	1	1	1.60	1941	79	-4	6	5221	5	5	8.0
2186	2185	CP	8	9.33	7.42	276.9	Sewer Drainage Basin #2	No		2	2	3	1	1	1.60	1941	79	-4	6	5131	5	5	8.0
2063	2062	CP	8	6.67	7.58	308.8	Sewer Drainage Basin #2	No		2	2	3	1	1	1.60	1941	79	-4	6	5142	5	5	8.0
1327-CO	1038	XXX	8	0	9	103.8	Sewer Drainage Basin #1	No		2	2	3	1	1	1.60	1963	57	18	5		0	5	8.0
2102	2307	CP	8	8.42	4.67	552.8	Sewer Drainage Basin #2	No		2	2	3	1	1	1.60	1941	79	-4	6	5241	5	5	8.0
1302	1301	CP	8	8.56	9.17	295.8	Sewer Drainage Basin #1	No		2	2	3	1	1	1.60	1963	57	18	5		0	5	8.0
1597	1596	PVC	8	4	8.33	176.3	Sewer Drainage Basin #1	No		2	2	3	1	1	1.60	1963	57	18	5		0	5	8.0
1380	1379	CP	8	8.3	8	59.9	Sewer Drainage Basin #1	No		2	2	3	1	1	1.60	1963	57	18	5		0	5	8.0
1381	1380	CP	8	8.7	8.3	114.9	Sewer Drainage Basin #1	No		2	2	3	1	1	1.60	1963	57	18	5		0	5	8.0
1389	1388	CP	8	6	9	159.0	Sewer Drainage Basin #1	No		2	2	3	1	1	1.60	1963	57	18	5		0	5	8.0
1395	1071	CP	8	5.8	9.5	331.9	Sewer Drainage Basin #1	No		2	2	3	1	1	1.60	1963	57	18	5		0	5	8.0
1396	1928	CP	8	9.3	0	173.2	Sewer Drainage Basin #1	No		2	2	3	1	1	1.60	1963	57	18	5		0	5	8.0
1397	1398	CP	8	5.3	8.3	341.5	Sewer Drainage Basin #1	No		2	2	3	1	1	1.60	1963	57	18	5		0	5	8.0
2173	2172	VCP	8	4.83	6.5	195.0	Sewer Drainage Basin #2	No		2	2	3	1	1	1.60	1941	79	-4	6	5133	5	5	8.0
4922	4099	CP	8	5.7	7.2	160.6	Sewer Drainage Basin #4	No		2	2	3	1	1	1.60	1974	46	29	4	5100	5	5	8.0
3103	3101	CP	8	6.83	6.25	211.4	Sewer Drainage Basin #3	No		2	2	3	1	1	1.60	1969	51	24	4	5131	5	5	8.0
1367	1921	CP	8	6.5	8.5	144.2	Sewer Drainage Basin #1	No		2	2	3	1	1	1.60	1963	57	18	5		0	5	8.0
1325	1324	CP	8	9.1	9.3	258.4	Sewer Drainage Basin #1	No		2	2	3	1	1	1.60	1963	57	18	5		0	5	8.0
1326-CO	1325	CP	8	0	9.1	120.8	Sewer Drainage Basin #1	No		2	2	3	1	1	1.60	1963	57	18	5		0	5	8.0
4048-CO	4047	CP	8	0	9.3	187.0	Sewer Drainage Basin #4	No		2	2	3	1	1	1.60	1974	46	29	4	5100	5	5	8.0
1347	1346	CP	8	6.6	5.7	145.7	Sewer Drainage Basin #1	No		2	2	3	1	1	1.60	1963	57	18	5		0	5	8.0
1388	1068	CP	8	9	7.5	334.8	Sewer Drainage Basin #1	No		2	2	3	1	1	1.60	1963	57	18	5		0	5	8.0
1363	1374	CP	8	9.43	9.5	48.5	Sewer Drainage Basin #1	No		2	2	3	1	1	1.60	1963	57	18	5		0	5	8.0
1364-CO	1922	CP	8	0	9.9	107.3	Sewer Drainage Basin #1	No		2	2	3	1	1	1.60	1963	57	18	5		0	5	8.0
1922	1363	CP	8	9.9	9.43	290.7	Sewer Drainage Basin #1	No		2	2	3	1	1	1.60	1963	57	18	5		0	5	8.0
1287	1286	CP	8	9.4	9	237.2	Sewer Drainage Basin #1	No		2	2	3	1	1	1.60	1963	57	18	5		0	5	8.0
1104	1090	CP	8	4.83	9.33	227.4	Sewer Drainage Basin #1	No		2	2	3	1	1	1.60	1963	57	18	5		0	5	8.0
1589	1572	CP	8	7.43	5.92	236.3	Sewer Drainage Basin #1	No		2	2	3	1	1	1.60	1963	57	18	5	513A	5	5	8.0
1038	1316	CP	8	8.6	9.6	392.6	Sewer Drainage Basin #1	No		2	2	3	1	1	1.60	1963	57	18	5		0	5	8.0
1486-CO	1485	CP	8	0	7.1	181.7	Sewer Drainage Basin #1B	No	Jetting Lines	2	2	3	1	1	1.60	1972	48	27	4		0	5	8.0
1487-CO	1485	CP	8	0	7.1	93.8	Sewer Drainage Basin #1B	No	Jetting Lines	2	2	3	1	1	1.60	1972	48	27	4		0	5	8.0
1504	1540	PVC	8	6	4.8	156.1	Sewer Drainage Basin #1	No		2	2	3	1	1	1.60	1963	57	18	5		0	5	8.0
1543	1540	CP	8	6	4.7	390.9	Sewer Drainage Basin #1	No		2	2	3	1	1	1.60	1963	57	18	5		0	5	8.0
1905	1266	CP	8	9.66	8	304.2	Sewer Drainage Basin #1	No		2	2	3	1	1	1.60	1963	57	18	5		0	5	8.0
1195	1371	CP	8	9.65	9.75	8.1	Sewer Drainage Basin #1	No		2	2	3	1	1	1.60	1963	57	18	5		0	5	8.0
1383	1382	CP	8	8.3	9.9	136.0	Sewer Drainage Basin #1	No		2	2	3	1	1	1.60	1963	57	18	5		0	5	8.0
3045	3044	CP	8	8.75	8.67	372.5	Sewer Drainage Basin #3	No		2	2	3	1	1	1.60	1969	51	24	4	5135	5	5	8.0
1993	1994	CP	8	6.6	3.9	159.4	Sewer Drainage Basin #1	No		2	2	3	1	1	1.60	1963	57	18	5		0	5	8.0
3426	3494	CP	8	8.83	7.25	205.1	Sewer Drainage Basin #3	No		2	2	3	1	1	1.60	1969	51	24	4	5132	5	5	8.0
1369-CO	1367	PVC	6	0	6.5	197.0	Sewer Drainage Basin #1	No		2	2	3	1	1	1.60	1963	57	18	5		0	5	8.0
1183	1182	CP	8	5.72	6.58	338.3	Sewer Drainage Basin #1	No		2	2	3	1	1	1.60	1963	57	18	5	5137	5	5	8.0
3465	3451	CP	8	8.42	5.58	259.0	Sewer Drainage Basin #3	No		2	2	3	1	1	1.60	1969	51	24	4	5100	5	5	8.0
1091	1090	VCP	8	9.1	9.75	104.2	Sewer Drainage Basin #1	No		2	2	3	1	1	1.60	1963	57	18	5		0	5	8.0
3302	3301	CP	8	12.9	16.7	353.3	Sewer Drainage Basin #3	No		2	4	4	1	1	1.95	1969	51	24	4	4223	4	4	7.8
1603	1602	PVC	8	17.1	11.9	203.1	Sewer Drainage Basin #1B	No		2	4	4	1	1	1.95	1972	48	27	4		0	4	7.8
3042	3041	CP	10	9	9	5.6	Sewer Drainage Basin #3	No		3	2	4	1	1	1.95	1969	51	24	4		0	4	7.8
3900	3944	CP	10	0	8.75	516.4	Sewer Drainage Basin #3	No		3	2	4	1	1	1.95	1969	51	24	4		0	4	7.8
1250	1027	CP	10	8.75	9	314.0	Sewer Drainage Basin #1	No		3	2	4	1	1	1.95	1963	57	18	5	3A2C	4	4	7.8
5051	5004	CP	8	6.2	7.7	103.4	Sewer Drainage Basin #5	No		2	2	5	1	2	1.95	1973	47	28	4		0	4	7.8
3470	3469	CP	8	11.83	12.5	352.1	Sewer Drainage Basin #3	No		2	3	3	1	6	1.95	1969	51	24	4	4121	4	4	7.8
3115	3114	CP	8	12.58	3.58	430.1	Sewer Drainage Basin #3	No		2	3	4	1	3	1.95	1969	51	24	4		0	4	7.8
3013	3059	CP	8	7.25	10.4	408.1	Sewer Drainage Basin #3	No		2	3	3	1	6	1.95	1969	51	24	4	4500	4	4	7.8
5049	5048	CP	8	7.2	10.6	50.4	Sewer Drainage Basin #5	No		2	3	3	1	6	1.95	1973	47	28	4		0	4	7.8
3918	3059	CP	8	12.1	10.4	55.1	Sewer Drainage Basin #3	No		2	3	3	1	6	1.95	1969	51	24	4	4100	4	4	7.8
5046	5045	CP	8	10.15	7.7	250.8	Sewer Drainage Basin #5	No		2	3	3	1	6	1.95	1973	47	28	4		0	4	7.8
3073	3072	CP	8	11.4	11.4	423.1	Sewer Drainage Basin #3	No		2	3	2	1	1	1.55	1969	51	24	4	5141	5	5	7.8
1109	1108	PVC	6	3.3	3.38	12.9	Sewer Drainage Basin #1	No		3	1	2	1	1	1.55	1963	57	18	5		0	5	7.8
5058	5054	CP	8	7	7.9	346.3	Sewer Drainage Basin #5	No		2	2	5	1	1	1.90	1973	47	28	4		0	4	7.6
1455	1411	CP	8	8	9.5	350.8	Sewer Drainage Basin #1B	No		2	2	5	1	1	1.90	1972	48	27	4		0	4	7.6
1439	1438	PVC	8	6.6	9.5	376.5	Sewer Drainage Basin #1B	No		2	2	4	1	4	1.90	1972	48	27	4				

UNITID	UNITID2	MATERIAL	DIAMETER	UP DEPTH	DOWN DEPTH	PIPE LENGTH	Drainage Basin	Backbone Pipe	Quarterly Maintenance	Pipe Diameter COF	Pipe Depth COF	Road Type COF	Seismic Backbone COF	Impact on Water Bodies COF	Weighted COF	Estimated Install Year	Estimated Pipe Age	Estimated Remaining Useful Life	LOF Based on Remaining Useful Life	PACP Quick Score (Overall)	PACP Based LOF (Rounded)	Final LOF	Risk
1496	1493	CP	8	6.92	6.4	290.4	Sewer Drainage Basin #1B	No		2	2	4	1	4	1.90	1972	48	27	4		0	4	7.6
4512	4001	CP	8	14	4	30.9	Sewer Drainage Basin #4	No		2	4	3	1	3	1.90	1974	46	29	4		0	4	7.6
3239	3238	CP	8	14.17	19.25	361.3	Sewer Drainage Basin #3	No		2	5	3	1	1	1.90	1969	51	24	4		0	4	7.6
3238	3237	CP	8	19.25	7.33	396.4	Sewer Drainage Basin #3	No		2	5	3	1	1	1.90	1969	51	24	4		0	4	7.6
1555-CO	1309	CP	8	0	3.33	113.6	Sewer Drainage Basin #1	No		2	1	3	No	1	1.50	1963	57	18	5		0	5	7.5
1598	1597	PVC	8	3.83	4	49.3	Sewer Drainage Basin #1	No		2	1	3	1	1	1.50	1963	57	18	5		0	5	7.5
1599	1598	PVC	8	4.41	3.83	85.9	Sewer Drainage Basin #1	No		2	1	3	1	1	1.50	1963	57	18	5		0	5	7.5
1542-CO	1540	PVC	8	0	4.7	99.9	Sewer Drainage Basin #1	No		2	1	3	1	1	1.50	1963	57	18	5		0	5	7.5
1346	1345	CP	8	5.7	4.8	196.3	Sewer Drainage Basin #1	No		2	1	3	No	1	1.50	1963	57	18	5		0	5	7.5
1105	1104	CP	8	3.95	4.83	261.7	Sewer Drainage Basin #1	No		2	1	3	1	1	1.50	1963	57	18	5		0	5	7.5
N1128	1127	CP	8	4.33	4.5	357.4	Sewer Drainage Basin #1	No		2	1	3	1	1	1.50	1963	57	18	5		0	5	7.5
1188-CO	1186	CP	8	0	5	80.8	Sewer Drainage Basin #1	No		2	1	3	1	1	1.50	1963	57	18	5		0	5	7.5
1994	1105	CP	8	3.9	3.95	135.7	Sewer Drainage Basin #1	No		2	1	3	No	1	1.50	1963	57	18	5		0	5	7.5
2074	2069	CP	8	10.33	8.66	426.9	Sewer Drainage Basin #2	No		2	3	4	1	1	1.85	1941	79	-4	6	4134	4	4	7.4
1459	1458	CP	8	10.7	11.2	399.4	Sewer Drainage Basin #1B	No		2	3	4	1	1	1.85	1972	48	27	4		0	4	7.4
1530	1459	CP	8	10.9	10.7	38.4	Sewer Drainage Basin #1B	No		2	3	4	1	1	1.85	1972	48	27	4		0	4	7.4
1451	1450	PVC	8	12.7	12	419.7	Sewer Drainage Basin #1B	No		2	3	4	No	1	1.85	1972	48	27	4		0	4	7.4
1590A-CO	1449	PVC	8	11	11.6	275.0	Sewer Drainage Basin #1B	No		2	3	4	1	1	1.85	1972	48	27	4		0	4	7.4
1310	1307	CP	8	8.5	11	295.2	Sewer Drainage Basin #1	No		2	3	4	1	1	1.85	1972	48	27	4		0	4	7.4
3247	3246	CP	8	11	9.8	274.6	Sewer Drainage Basin #3	No		2	3	4	1	1	1.85	1969	51	24	4	4100	4	4	7.4
3046	3045	CP	8	13.25	8.92	339.8	Sewer Drainage Basin #3	No		2	3	4	1	1	1.85	1969	51	24	4	4131	4	4	7.4
1447	1446	PVC	8	10	9.3	161.5	Sewer Drainage Basin #1B	No		2	3	4	1	1	1.85	1972	48	27	4		0	4	7.4
1448	1447	PVC	8	10.6	9.7	116.5	Sewer Drainage Basin #1B	No		2	3	4	1	1	1.85	1972	48	27	4		0	4	7.4
1449	1448	PVC	8	11	10.6	118.3	Sewer Drainage Basin #1B	No		2	3	4	1	1	1.85	1972	48	27	4		0	4	7.4
1450	1449	PVC	8	12	11	310.7	Sewer Drainage Basin #1B	No		2	3	4	No	1	1.85	1972	48	27	4		0	4	7.4
1519	1450	CP	8	10.5	12	232.2	Sewer Drainage Basin #1B	No		2	3	4	1	1	1.85	1972	48	27	4		0	4	7.4
3187	3186	CP	8	12	13.5	230.4	Sewer Drainage Basin #3	No		2	3	4	1	1	1.85	1969	51	24	4	4100	4	4	7.4
1743	1745	CP	8	12.5	12.25	424.0	Sewer Drainage Basin #1B	No		2	3	4	1	1	1.85	1972	48	27	4		0	4	7.4
1744	1743	CP	8	12	12.5	396.3	Sewer Drainage Basin #1B	No		2	3	4	1	1	1.85	1972	48	27	4		0	4	7.4
1602	1447	PVC	8	11.9	10	42.3	Sewer Drainage Basin #1B	No		2	3	4	1	1	1.85	1972	48	27	4		0	4	7.4
1582	1448	CP	8	12	10.5	74.4	Sewer Drainage Basin #1B	No		2	3	4	1	1	1.85	1972	48	27	4		0	4	7.4
1531	1530	CP	8	0	10.9	423.3	Sewer Drainage Basin #1B	No		2	3	4	1	1	1.85	1972	48	27	4		0	4	7.4
1460-CO	1530	CP	8	0	10.9	141.2	Sewer Drainage Basin #1B	No		2	3	4	1	1	1.85	1972	48	27	4		0	4	7.4
4054	CCMH049	CP	8	18.8	0	23.4	Sewer Drainage Basin #4	No		2	5	1	1	6	1.85	1974	46	29	4		0	4	7.4
5045	5041	CP	8	7.7	8.4	361.1	Sewer Drainage Basin #5	No		2	2	3	1	6	1.85	1973	47	28	4		0	4	7.4
5048	5023	CP	8	7.9	8.1	145.7	Sewer Drainage Basin #5	No		2	2	3	1	6	1.85	1973	47	28	4		0	4	7.4
5050	5049	CP	8	8	7.2	186.6	Sewer Drainage Basin #5	No		2	2	3	1	6	1.85	1973	47	28	4		0	4	7.4
3060	3059	CP	8	8	9.5	46.0	Sewer Drainage Basin #3	No		2	2	3	1	6	1.85	1969	51	24	4	4200	4	4	7.4
4049	4936	CP	8	9.5	6.6	292.8	Sewer Drainage Basin #4	No		2	2	3	1	6	1.85	1974	46	29	4	4122	4	4	7.4
4074	4935	CP	8	9.23	7.75	127.0	Sewer Drainage Basin #4	No		2	2	3	1	6	1.85	1974	46	29	4		0	4	7.4
1529	1113	VCP	8	6.15	6.6	50.5	Sewer Drainage Basin #1	No		2	2	2	1	1	1.45	1963	57	18	5		0	5	7.3
1095	1094	VCP	8	2.7	6.17	387.1	Sewer Drainage Basin #1	No		2	2	2	1	1	1.45	1963	57	18	5		0	5	7.3
1142	1123	CAS	6	4	4.58	40.0	Sewer Drainage Basin #1	No		1	1	3	1	4	1.45	1963	57	18	5		0	5	7.3
2272	2271	CP	8	0	0	33.0	Sewer Drainage Basin #2	No		2	1	1	No	1	1.20	1941	79	-4	6		0	6	7.2
2177	2145	PE	8	0	0	348.8	Sewer Drainage Basin #2	No		2	1	5	1	1	1.80	2018	2	73	1	4121	4	4	7.2
5082-CO	5017	CP	8	0	9.83	113.7	Sewer Drainage Basin #5	No		2	2	3	1	5	1.80	1973	47	28	4		0	4	7.2
5025	5024	XXX	8	9.33	10	174.6	Sewer Drainage Basin #5	No		2	3	2	1	6	1.80	1973	47	28	4		0	4	7.2
5024	5023	XXX	8	10	8.33	93.9	Sewer Drainage Basin #5	No		2	3	2	No	1	1.80	1973	47	28	4		0	4	7.2
4022	4512	CP	8	10.7	9.5	164.8	Sewer Drainage Basin #4	No		2	3	3	1	3	1.80	1974	46	29	4		0	4	7.2
1430	1429	CP	10	6.2	7.5	418.6	Sewer Drainage Basin #1B	No		3	2	3	1	1	1.80	1972	48	27	4		0	4	7.2
N6051B	SMS5	XXX	0	0	0	14.3	Sewer Drainage Basin #1B	No		1	1	5	1	5	1.80	1972	48	27	4		0	4	7.2
5073-CO	5072	XXX	8	0	15.83	59.2	Sewer Drainage Basin #5	No		2	4	3	1	1	1.80	1973	47	28	4		0	4	7.2
1559	1561	PVC	8	13.25	15.5	247.5	Sewer Drainage Basin #1	No		2	4	3	1	1	1.80	1969	51	24	4		0	4	7.2
5063	5062	CP	8	15	13.83	110.1	Sewer Drainage Basin #5	No		2	4	3	1	1	1.80	1973	47	28	4	4111	4	4	7.2
4064	4058	CP	8	10.2	14.3	220.9	Sewer Drainage Basin #4	No		2	4	3	1	1	1.80	1974	46	29	4	3726	4	4	7.2
1762	1737	CP	8	12.4	14.3	322.1	Sewer Drainage Basin #1B	No		2	4	3	1	1	1.80	1972	48	27	4		0	4	7.2
4066	4060	CP	8	10.2	15.5	389.2	Sewer Drainage Basin #4	No		2	4	3	1	1	1.80	1974	46	29	4	413C	4	4	7.2
1738	1737	CP	8	9.58	14.3	148.7	Sewer Drainage Basin #1B	No		2	4	3	1	1	1.80	1972	48	27	4		0	4	7.2
1478	1477	CP	8	14.7	10.1	253.4	Sewer Drainage Basin #1B	No		2	4	3	1	1	1.80	1972	48	27	4		0	4	7.2
1479	1478	CP	8	10.3	14.7	194.1	Sewer Drainage Basin #1B	No		2	4	3	1	1	1.80	1972	48	27	4		0	4	7.2
1534	1533	PVC	8	14	7.7	100.3	Sewer Drainage Basin #1B	No		2	4	3	1	1	1.80	1972	48	27	4		0	4	7.2
1535	1534	PVC	8	6.7	14	358.5	Sewer Drainage Basin #1B	No		2	4	3	1	1	1.80	1972	48	27	4		0	4	7.2
3252	3241	CP	8	11.92	17	336.9	Sewer Drainage Basin #3	No		2	4	3	1	1	1.80	1969	51	24	4		0	4	7.2
1560	1561	PVC	8	10.25	15.5	263.6	Sewer Drainage Basin #1	No		2	4	3	No	1	1.80	1969	51	24	4		0	4	7.2
3047	3046	CP	8	16	13.25	323.7	Sewer Drainage Basin #3	No		2	4	3	1	1	1.80	1969	51	24	4		0	4	7.2
1737	1758	CP	8	14.3	9.5	241.5	Sewer Drainage Basin #1B	No		2	4	3	1	1	1.80	1972	48	27	4		0	4	7.2
3242	3241	CP	8	12.5	17	330.6	Sewer Drainage Basin #3	No		2	4	3	1	1	1.80	1969	51	24	4		0	4	7.2
3241	3240	CP	8	17	13	329.3	Sewer Drainage Basin #3	No		2	4	3	1	1	1.80	1969	51	24	4		0	4	7.2
3240	3239	CP	8	13	14.17	391.2	Sewer Drainage Basin #3	No		2	4	3	1	1	1.80	1969	51	24	4		0	4	7.2
3251	323																						



UNITID	UNITID2	MATERIAL	DIAMETER	UP DEPTH	DOWN DEPTH	PIPE LENGTH	Drainage Basin	Backbone Pipe	Quarterly Maintenance	Pipe Diameter COF	Pipe Depth COF	Road Type COF	Seismic Backbone COF	Impact on Water Bodies COF	Weighted COF	Estimated Install Year	Estimated Pipe Age	Estimated Remaining Useful Life	LOF Based on Remaining Useful Life	PACP Quick Score (Overall)	PACP Based LOF (Rounded)	Final LOF	Risk
5035	5016	CP	8	8.17	11	289.0	Sewer Drainage Basin #5	No		2	3	3	1	2	1.75	1973	47	28	4		0	4	7.0
2076-CO	2075	CP	8	0	8.82	174.6	Sewer Drainage Basin #2	No		2	2	4	1	1	1.75	1941	79	-4	6	4121	4	4	7.0
1437	1436	PVC	8	9.4	9.3	20.1	Sewer Drainage Basin #1B	No		2	2	4	1	1	1.75	1972	48	27	4		0	4	7.0
1436	1435	PVC	8	9.3	6.4	361.0	Sewer Drainage Basin #1B	No		2	2	4	1	1	1.75	1972	48	27	4		0	4	7.0
1502	1503	PVC	8	6.08	9	397.3	Sewer Drainage Basin #1B	No		2	2	4	1	1	1.75	1972	48	27	4		0	4	7.0
1438	1437	PVC	8	9.5	9.4	130.4	Sewer Drainage Basin #1B	No		2	2	4	1	1	1.75	1972	48	27	4		0	4	7.0
1503	1438	PVC	8	9	9.25	261.3	Sewer Drainage Basin #1B	No		2	2	4	1	1	1.75	1972	48	27	4		0	4	7.0
3925	3134	CP	8	8.08	7.33	130.0	Sewer Drainage Basin #3	No		2	2	4	1	1	1.75	1969	51	24	4	4121	4	4	7.0
1491	1490	CP	8	6.2	7.5	193.7	Sewer Drainage Basin #1B	No		2	2	4	1	1	1.75	1972	48	27	4		0	4	7.0
1444	1443	PVC	8	8.8	7.7	236.7	Sewer Drainage Basin #1B	No		2	2	4	1	1	1.75	1972	48	27	4		0	4	7.0
1445	1444	PVC	8	7.4	8.8	48.1	Sewer Drainage Basin #1B	No		2	2	4	1	1	1.75	1972	48	27	4		0	4	7.0
1446	1445	PVC	8	9.3	7.4	80.8	Sewer Drainage Basin #1B	No		2	2	4	1	1	1.75	1972	48	27	4		0	4	7.0
1499	1445	PVC	8	8.7	7.4	476.5	Sewer Drainage Basin #1B	No		2	2	4	1	1	1.75	1972	48	27	4		0	4	7.0
3092	3091	CP	8	7.91	8.17	241.9	Sewer Drainage Basin #3	No		2	2	4	1	1	1.75	1969	51	24	4	4112	4	4	7.0
2095	2084	CP	8	9.08	8.67	412.3	Sewer Drainage Basin #2	No		2	2	4	1	1	1.75	1941	79	-4	6	3622	4	4	7.0
3236	3142	CP	8	7.67	9.67	324.6	Sewer Drainage Basin #3	No		2	2	4	1	1	1.75	1969	51	24	4		0	4	7.0
1517-CO	1444	PVC	8	0	8.8	74.7	Sewer Drainage Basin #1B	No		2	2	4	1	1	1.75	1972	48	27	4		0	4	7.0
2911	2053	CP	6	5.67	7.33	398.8	Sewer Drainage Basin #2	No		1	2	3	1	1	1.40	1941	79	-4	6	5142	5	5	7.0
SMS5	SV1006	XXX	0	0	0	5.1	Sewer Drainage Basin #1B	No		1	1	5	1	4	1.75	1972	48	27	4		0	4	7.0
1995	1250	CP	8	6	7	347.1	Sewer Drainage Basin #1	No		1	2	3	1	1	1.40	1963	57	18	5	512C	5	5	7.0
4936	CCMH054	CP	8	0	0	0.0	Sewer Drainage Basin #4	No		2	1	3	1	6	1.75	1974	46	29	4		0	4	7.0
5041	5040	CP	8	8.4	8.9	69.8	Sewer Drainage Basin #5	No		2	2	3	1	4	1.75	1973	47	28	4		0	4	7.0
1440	1439	PVC	8	6.5	6.6	29.9	Sewer Drainage Basin #1B	No		2	2	3	1	4	1.75	1972	48	27	4		0	4	7.0
1516	1496	CP	8	7.3	6.92	186.8	Sewer Drainage Basin #1B	No		2	2	3	1	4	1.75	1972	48	27	4		0	4	7.0
1515	1510	CP	8	3.7	6	235.6	Sewer Drainage Basin #1B	No		2	2	3	1	4	1.75	1972	48	27	4		0	4	7.0
2152	2151	CP	10	9.2	16.91	357.9	Sewer Drainage Basin #2	No		3	4	5	1	1	2.30	1941	79	-4	6	2G11	3	3	6.9
2120	2118	CP	8	5.92	5.67	254.1	Sewer Drainage Basin #2	No	Flushing Lines	3	1	3	1	1	1.70	1941	79	-4	6	4300	4	4	6.8
6051WW	SV1000	XXX	0	0	0	5.2	Sewer Drainage Basin #1B	No		2	1	3	1	5	1.70	1972	48	27	4		0	4	6.8
SV1000	5-PUMP1_0	XXX	0	0	0	1.0	Sewer Drainage Basin #1B	No		2	1	3	1	5	1.70	1972	48	27	4		0	4	6.8
3243	3242	CP	8	12.75	11.75	186.1	Sewer Drainage Basin #3	No		2	3	3	1	1	1.70	1969	51	24	4		0	4	6.8
3258	3243	CP	8	9.25	12.75	239.9	Sewer Drainage Basin #3	No		2	3	3	1	1	1.70	1969	51	24	4		0	4	6.8
5072	5069	CP	8	13.83	6.67	140.5	Sewer Drainage Basin #5	No		2	3	3	1	1	1.70	1973	47	28	4		0	4	6.8
1910	1200	CP	8	11.58	12.3	372.0	Sewer Drainage Basin #1	No	Root-X	2	3	3	1	1	1.70	1963	57	18	5	3C29	4	4	6.8
1557-CO	1559	PVC	8	0	13.25	77.5	Sewer Drainage Basin #1	No		2	3	3	1	1	1.70	1969	51	24	4		0	4	6.8
3409-CO	3408	CP	8	0	11.42	146.2	Sewer Drainage Basin #3	No		2	3	3	1	1	1.70	1969	51	24	4		0	4	6.8
3408	3392	CP	8	11.42	8.08	189.2	Sewer Drainage Basin #3	No		2	3	3	1	1	1.70	1969	51	24	4		0	4	6.8
2243	2902	CP	8	10.92	9	589.2	Sewer Drainage Basin #2	No		2	3	3	1	1	1.70	1941	79	-4	6	382E	4	4	6.8
2187	2186	CP	8	10.42	9.33	170.1	Sewer Drainage Basin #2	No		2	3	3	1	1	1.70	1941	79	-4	6	4124	4	4	6.8
5071	5070	CP	8	6.55	11.2	146.6	Sewer Drainage Basin #5	No		2	3	3	1	1	1.70	1973	47	28	4		0	4	6.8
5056	5055	CP	8	7.75	12.25	496.5	Sewer Drainage Basin #5	No		2	3	3	1	1	1.70	1973	47	28	4		0	4	6.8
5034-CO	5033	CP	8	0	10.33	245.2	Sewer Drainage Basin #5	No		2	3	3	1	1	1.70	1973	47	28	4		0	4	6.8
5033	5032	CP	8	10.33	10	358.9	Sewer Drainage Basin #5	No		2	3	3	1	1	1.70	1973	47	28	4		0	4	6.8
5032	5031	CP	8	10	8.6	220.4	Sewer Drainage Basin #5	No		2	3	3	1	1	1.70	1973	47	28	4		0	4	6.8
5031	5014	CP	8	5.6	11.75	148.6	Sewer Drainage Basin #5	No		2	3	3	1	1	1.70	1973	47	28	4		0	4	6.8
5077	5046	CP	8	5.3	10.15	233.5	Sewer Drainage Basin #5	No		2	3	3	1	1	1.70	1973	47	28	4		0	4	6.8
4096	4095	CP	8	8.8	11	163.3	Sewer Drainage Basin #4	No		2	3	3	1	1	1.70	1974	46	29	4	4111	4	4	6.8
1441	1440	PVC	8	5.6	6.5	279.9	Sewer Drainage Basin #1B	No		2	2	3	1	3	1.70	1972	48	27	4		0	4	6.8
3341	3927	CP	8	9.42	12.67	286.9	Sewer Drainage Basin #3	No		2	3	3	1	1	1.70	1969	51	24	4		0	4	6.8
3212	3211	CP	8	10.25	9.42	398.1	Sewer Drainage Basin #3	No	Flushing Lines	2	3	3	1	1	1.70	1969	51	24	4	412E	4	4	6.8
3213	3212	CP	8	8.83	10.25	429.8	Sewer Drainage Basin #3	No		2	3	3	1	1	1.70	1969	51	24	4	412A	4	4	6.8
4062	4061	CP	8	8.5	12.25	300.5	Sewer Drainage Basin #4	No		2	3	3	1	1	1.70	1974	46	29	4	4121	4	4	6.8
1468	1467	CP	8	8.5	8.1	299.8	Sewer Drainage Basin #1B	No		2	2	3	1	3	1.70	1972	48	27	4		0	4	6.8
1469	1468	CP	8	9.3	8.5	441.7	Sewer Drainage Basin #1B	No		2	2	3	1	3	1.70	1972	48	27	4		0	4	6.8
1470	1469	CP	8	7.8	9.3	429.3	Sewer Drainage Basin #1B	No		2	2	3	1	3	1.70	1972	48	27	4		0	4	6.8
3504	3128	CP	8	6.75	12.92	120.0	Sewer Drainage Basin #3	No		2	3	3	1	1	1.70	1969	51	24	4	4133	4	4	6.8
4921-CO	4039	CP	8	0	11	149.1	Sewer Drainage Basin #4	No		2	3	3	1	1	1.70	1974	46	29	4	4100	4	4	6.8
3257	3911	CP	8	12.33	9.42	305.0	Sewer Drainage Basin #3	No		2	3	3	1	1	1.70	1969	51	24	4		0	4	6.8
1740	1738	CP	8	10	9.25	213.7	Sewer Drainage Basin #1B	No		2	3	3	1	1	1.70	1972	48	27	4		0	4	6.8
1742	1740	CP	8	10.58	10	215.8	Sewer Drainage Basin #1B	No		2	3	3	1	1	1.70	1972	48	27	4		0	4	6.8
1741	1739	CP	8	10.17	11	166.3	Sewer Drainage Basin #1B	No		2	3	3	1	1	1.70	1972	48	27	4		0	4	6.8
3124	3123	CP	8	7.58	10.08	387.5	Sewer Drainage Basin #3	No		2	3	3	1	1	1.70	1969	51	24	4	4131	4	4	6.8
1558	1559	PVC	8	11.17	13.25	136.5	Sewer Drainage Basin #1	No		2	3	3	1	1	1.70	1969	51	24	4		0	4	6.8
2111	2110	CP	8	11.33	9.17	465.7	Sewer Drainage Basin #2	No		2	3	3	1	1	1.70	1941	79	-4	6	4131	4	4	6.8
5062	5061	CP	8	13.83	6.5	347.3	Sewer Drainage Basin #5	No		2	3	3	1	1	1.70	1973	47	28	4		0	4	6.8
5069	5062	CP	8	6.67	13.83	257.7	Sewer Drainage Basin #5	No		2	3	3	1	1	1.70	1973	47	28	4		0	4	6.8
5070	5069	CP	8	11.2	6.67	258.8	Sewer Drainage Basin #5	No		2	3	3	1	1	1.70	1973	47	28	4		0	4	6.8
1246	1240	CP	8	11.58	9.75	153.6	Sewer Drainage Basin #1	No		2	3	3	1	1	1.70	1969	51	24	4		0	4	6.8
1477	1471	CP	8	10.1	6.7	126.1	Sewer Drainage Basin #1B	No		2	3	3	1	1	1.70	1972	48	27	4		0	4	6.8
1505	1318	CP	8	11	10.4	266.1	Sewer Drainage Basin #1	No		2	3												



UNITID	UNITID2	MATERIAL	DIAMETER	UP DEPTH	DOWN DEPTH	PIPE LENGTH	Drainage Basin	Backbone Pipe	Quarterly Maintenance	Pipe Diameter COF	Pipe Depth COF	Road Type COF	Seismic Backbone COF	Impact on Water Bodies COF	Weighted COF	Estimated Install Year	Estimated Pipe Age	Estimated Remaining Useful Life	LOF Based on Remaining Useful Life	PACP Quick Score (Overall)	PACP Based LOF (Rounded)	Final LOF	Risk
1538	1536	PVC	8	7.5	10.4	357.0	Sewer Drainage Basin #1B	No		2	3	3	1	1	1.70	1972	48	27	4		0	4	6.8
3253	3252	CP	8	9.25	11.75	282.9	Sewer Drainage Basin #3	No		2	3	3	1	1	1.70	1969	51	24	4		0	4	6.8
3254	3241	CP	8	12.5	9.1	415.4	Sewer Drainage Basin #3	No		2	3	3	1	1	1.70	1969	51	24	4		0	4	6.8
4501	4500	PVC	8	7.33	9.33	322.0	Sewer Drainage Basin #4	No		2	2	3	1	3	1.70	1974	46	29	4		0	4	6.8
1453	1452	CP	8	12.2	9.3	351.9	Sewer Drainage Basin #1B	No		2	3	3	1	1	1.70	1972	48	27	4		0	4	6.8
1462	1461	CP	8	8.66	12.66	390.2	Sewer Drainage Basin #1B	No		2	3	3	1	1	1.70	1972	48	27	4		0	4	6.8
1464	1461	PVC	8	8.67	11	233.9	Sewer Drainage Basin #1B	No		2	3	3	1	1	1.70	1972	48	27	4		0	4	6.8
4072	4071	CP	8	9	10	243.3	Sewer Drainage Basin #4	No		2	3	3	1	1	1.70	1974	46	29	4	4100	4	4	6.8
5047	5046	CP	8	6.2	10.15	291.2	Sewer Drainage Basin #5	No		2	3	3	1	1	1.70	1973	47	28	4		0	4	6.8
1222	1220	CP	8	12	8.25	343.5	Sewer Drainage Basin #1	No		2	3	3	1	1	1.70	1963	57	18	5	3A25	4	4	6.8
4200	4082	CP	8	7.33	12.33	249.7	Sewer Drainage Basin #4	No		2	3	3	1	1	1.70	1974	46	29	4	4100	4	4	6.8
4920-CO	4079	CP	8	0	7.6	199.1	Sewer Drainage Basin #4	No		2	2	3	1	3	1.70	1974	46	29	4	4100	4	4	6.8
4090	4089	CP	8	10.2	6.4	185.0	Sewer Drainage Basin #4	No		2	3	3	1	1	1.70	1974	46	29	4	4100	4	4	6.8
5081-CO	5036	CP	8	0	12.33	93.0	Sewer Drainage Basin #5	No		2	3	3	1	1	1.70	1973	47	28	4		0	4	6.8
4073	4068	CP	8	9.5	10.08	282.1	Sewer Drainage Basin #4	No		2	3	3	1	1	1.70	1974	46	29	4	4200	4	4	6.8
4071	4068	CP	8	9.9	10.66	8.0	Sewer Drainage Basin #4	No		2	3	3	1	1	1.70	1974	46	29	4	4131	4	4	6.8
1583	1582	PVC	8	6.1	12	390.7	Sewer Drainage Basin #1B	No		2	3	3	1	1	1.70	1972	48	27	4		0	4	6.8
1527-CO	1453	CP	8	0	12.2	50.5	Sewer Drainage Basin #1B	No		2	3	3	1	1	1.70	1972	48	27	4		0	4	6.8
3255	3254	CP	8	13	12.5	19.0	Sewer Drainage Basin #3	No		2	3	3	1	1	1.70	1969	51	24	4		0	4	6.8
3256	3255	CP	8	10	13	311.2	Sewer Drainage Basin #3	No		2	3	3	1	1	1.70	1969	51	24	4		0	4	6.8
3911	3256	CP	8	9.42	10	411.8	Sewer Drainage Basin #3	No		2	3	3	1	1	1.70	1969	51	24	4		0	4	6.8
2167	2166	CP	8	5	10.5	343.7	Sewer Drainage Basin #2	No		2	3	3	1	1	1.70	1941	79	-4	6	4327	4	4	6.8
1739	1749WW	CP	8	11.25	11.75	27.1	Sewer Drainage Basin #1B	No		2	3	3	1	1	1.70	1972	48	27	4		0	4	6.8
2309-CO	2100	CP	8	0	10	163.0	Sewer Drainage Basin #2	No		2	3	3	1	1	1.70	1941	79	-4	6	3D26	4	4	6.8
1749WW	1738	CAS	4	22	9.58	11.0	Sewer Drainage Basin #1B	No		1	5	3	1	1	1.70	1972	48	27	4		0	4	6.8
3937	3938	PVC	8	11.29	9.04	181.7	Sewer Drainage Basin #3	No		2	3	3	1	1	1.70	1969	51	24	4		0	4	6.8
1097	1096	CP	8	5.75	5.17	165.1	Sewer Drainage Basin #1	No		2	1	2	1	1	1.35	1963	57	18	5		0	5	6.8
1114	1103	CP	8	5.33	2.88	186.3	Sewer Drainage Basin #1	No		2	1	2	1	1	1.35	1963	57	18	5		0	5	6.8
1522	1114	CP	8	4.68	5.33	108.3	Sewer Drainage Basin #1	No		2	1	2	1	1	1.35	1963	57	18	5		0	5	6.8
1524	1522	CP	8	4.75	4.68	117.2	Sewer Drainage Basin #1	No		2	1	2	1	1	1.35	1963	57	18	5		0	5	6.8
1096	1095	CP	8	5.1	2.7	246.5	Sewer Drainage Basin #1	No		2	1	2	1	1	1.35	1963	57	18	5		0	5	6.8
1901	1167	CP	10	7	7.33	204.2	Sewer Drainage Basin #1	No		3	2	6	1	1	2.25	1963	57	18	5	2.00E+00	3.00E+00	3	6.8
1179	1901	CP	10	5.5	7	308.9	Sewer Drainage Basin #1	No		3	2	6	1	1	2.25	1963	57	18	5	2G00	3	3	6.8
2251	2325	CP	10	6.33	8.92	224.8	Sewer Drainage Basin #2	No		3	2	6	1	1	2.25	1941	79	-4	6	2D00	3	3	6.8
1108	1107	PVC	6	3.38	3.46	170.9	Sewer Drainage Basin #1	No		2	1	2	1	1	1.35	1963	57	18	5		0	5	6.8
1150	1149	PVC	8	4.7	4.2	72.0	Sewer Drainage Basin #1	No		2	1	2	1	1	1.35	1963	57	18	5		0	5	6.8
1191-CO	1190	CP	8	5	5.75	126.2	Sewer Drainage Basin #1	No		2	1	4	1	1	1.65	1963	57	18	5	4138	4	4	6.6
SV1011	SV1013	XXX	0	0	0	1.1	Sewer Drainage Basin #3	No		2	1	4	1	1	1.65	1969	51	24	4		0	4	6.6
3429-CO	3450	CP	8	0	6.92	168.7	Sewer Drainage Basin #3	No		2	2	3	1	2	1.65	1969	51	24	4		0	4	6.6
5043	5041	CP	8	7	8.4	357.6	Sewer Drainage Basin #5	No		2	2	3	1	2	1.65	1973	47	28	4		0	4	6.6
4013	4011	CP	8	8.5	9.3	409.0	Sewer Drainage Basin #4	No		2	2	3	1	2	1.65	1974	46	29	4	382N	4	4	6.6
5042-CO	5041	CP	8	0	8.4	148.6	Sewer Drainage Basin #5	No		2	2	3	1	2	1.65	1973	47	28	4		0	4	6.6
5044-CO	5043	CP	8	0	7	145.6	Sewer Drainage Basin #5	No		2	2	3	1	2	1.65	1973	47	28	4		0	4	6.6
4094	4089	CP	8	5.3	8.5	309.6	Sewer Drainage Basin #4	No		2	2	3	1	2	1.65	1974	46	29	4	4225	4	4	6.6
1475	1474	CP	8	6.6	6.7	101.3	Sewer Drainage Basin #1B	No		2	2	3	1	2	1.65	1972	48	27	4		0	4	6.6
1476	1475	CP	8	6.4	6.6	104.2	Sewer Drainage Basin #1B	No		2	2	3	1	2	1.65	1972	48	27	4		0	4	6.6
1510	1435	CP	8	6	6.4	85.5	Sewer Drainage Basin #1B	No		2	2	3	1	2	1.65	1972	48	27	4		0	4	6.6
1511	1510	PVC	8	6	6	212.3	Sewer Drainage Basin #1B	No		2	2	3	1	2	1.65	1972	48	27	4		0	4	6.6
2328-CO	2242	CP	8	0	9.08	392.7	Sewer Drainage Basin #2	No		2	2	3	1	2	1.65	1941	79	-4	6	3725	4	4	6.6
3221	3220	CP	8	9.5	9.58	138.6	Sewer Drainage Basin #3	No		2	2	3	1	2	1.65	1969	51	24	4		0	4	6.6
1518-CO	1476	CP	8	0	6.4	237.1	Sewer Drainage Basin #1B	No		2	2	3	1	2	1.65	1972	48	27	4		0	4	6.6
5018WW	5017	DIP	8	0	9.83	85.9	Sewer Drainage Basin #5	No		1	2	3	1	6	1.65	1973	47	28	4		0	4	6.6
1113	1098	VCP	8	6.6	7.4	145.7	Sewer Drainage Basin #1	No		2	2	1	1	1	1.30	1963	57	18	5		0	5	6.5
1098	1097	VCP	8	7.4	5.75	141.8	Sewer Drainage Basin #1	No		2	2	1	1	1	1.30	1963	57	18	5		0	5	6.5
1099	1098	CP	8	4.25	7.75	253.2	Sewer Drainage Basin #1	No		2	2	1	1	1	1.30	1963	57	18	5		0	5	6.5
1094	1093	VCP	8	6.17	4.5	398.9	Sewer Drainage Basin #1	No		2	2	1	1	1	1.30	1963	57	18	5		0	5	6.5
1092	1112-CO	VCP	8	5.75	7.83	334.2	Sewer Drainage Basin #1	No		2	2	1	1	1	1.30	1963	57	18	5		0	5	6.5
1101	1100	CP	8	7.58	3.83	32.7	Sewer Drainage Basin #1	No		2	2	1	1	1	1.30	1963	57	18	5		0	5	6.5
1093	1091	CP	8	4.33	9.17	352.0	Sewer Drainage Basin #1	No		2	2	1	1	1	1.30	1963	57	18	5		0	5	6.5
1400	1402	CP	8	6.8	9.3	163.1	Sewer Drainage Basin #1	No		2	2	1	1	1	1.30	1963	57	18	5		0	5	6.5
1102	1101	VCP	8	4.6	7.58	173.5	Sewer Drainage Basin #1	No		2	2	1	1	1	1.30	1963	57	18	5		0	5	6.5
PRMH046	PRMH045	PVC	8	0	0	156.1	Sewer Drainage Basin #1	No		2	1	1	1	3	1.30	1963	57	18	5		0	5	6.5
1090-CO	1090	CP	6	0	0	38.7	Sewer Drainage Basin #1	No		1	1	3	1	1	1.30	1963	57	18	5		0	5	6.5
1180	1179	CP	10	5.33	5.5	196.2	Sewer Drainage Basin #1	No		3	1	6	1	1	2.15	1963	57	18	5	2F00	3	3	6.5
2320	2370	CP	8	7.4	11.7	156.2	Sewer Drainage Basin #2	No		2	3	6	1	1	2.15	1970	50	25	4	2900	3	3	6.5
2330	2281	CP	8	7.58	11	165.8	Sewer Drainage Basin #2	No		2	3	6	1	1	2.15	1941	79	-4	6	2700	3	3	6.5
1924	1998	PVC	8	0	0	337.8	Sewer Drainage Basin #2	No		3	1	6	1	1	2.15	2017	3	72	1	2900	3	3	6.5
2262	2261	CP	10	14.5	6.83	394.3	Sewer Drainage Basin #2	No		3	4	4	1	1	2.15	1941	79	-4	6	322H	3	3	6.5
3824	CCMH064	XXX	0	0	0	7.9	Sewer Drainage Basin #3	No		1	1	5	1	1	1.60	1969							

UNITID	UNITID2	MATERIAL	DIAMETER	UP DEPTH	DOWN DEPTH	PIPE LENGTH	Drainage Basin	Backbone Pipe	Quarterly Maintenance	Pipe Diameter COF	Pipe Depth COF	Road Type COF	Seismic Backbone COF	Impact on Water Bodies COF	Weighted COF	Estimated Install Year	Estimated Pipe Age	Estimated Remaining Useful Life	LOF Based on Remaining Useful Life	PACP Quick Score (Overall)	PACP Based LOF (Rounded)	Final LOF	Risk
3406-CO	3405	CP	8	0	6.92	101.4	Sewer Drainage Basin #3	No		2	2	3	1	1	1.60	1969	51	24	4		0	4	6.4
3405	3404	CP	8	6.92	6.75	208.8	Sewer Drainage Basin #3	No		2	2	3	1	1	1.60	1969	51	24	4		0	4	6.4
3400	3399	CP	8	6.75	7.25	264.0	Sewer Drainage Basin #3	No		2	2	3	1	1	1.60	1969	51	24	4		0	4	6.4
3443	3398	CP	8	6.83	9.25	301.8	Sewer Drainage Basin #3	No		2	2	3	1	1	1.60	1969	51	24	4		0	4	6.4
3352	3351	CP	8	8	6.33	203.7	Sewer Drainage Basin #3	No		2	2	3	1	1	1.60	1969	51	24	4	4121	4	4	6.4
3393	3392	CP	8	8.92	8.08	256.6	Sewer Drainage Basin #3	No		2	2	3	1	1	1.60	1969	51	24	4		0	4	6.4
3394	3393	CP	8	5.92	8.92	213.1	Sewer Drainage Basin #3	No		2	2	3	1	1	1.60	1969	51	24	4		0	4	6.4
3395	3394	CP	8	6.83	5.92	138.7	Sewer Drainage Basin #3	No		2	2	3	1	1	1.60	1969	51	24	4		0	4	6.4
3396	3395	CP	8	7.75	6.83	117.9	Sewer Drainage Basin #3	No		2	2	3	1	1	1.60	1969	51	24	4		0	4	6.4
3410	3500	CP	8	8.83	9.83	195.5	Sewer Drainage Basin #3	No		2	2	3	1	1	1.60	1969	51	24	4		0	4	6.4
3500	3393	CP	8	9.83	8.92	89.5	Sewer Drainage Basin #3	No		2	2	3	1	1	1.60	1969	51	24	4		0	4	6.4
3423	3422	CP	8	6.92	7.42	145.3	Sewer Drainage Basin #3	No		2	2	3	1	1	1.60	1969	51	24	4	4131	4	4	6.4
3445-CO	3444	CP	8	0	8.75	162.5	Sewer Drainage Basin #3	No		2	2	3	1	1	1.60	1969	51	24	4		0	4	6.4
3447	3446	CP	8	4.75	6.83	281.1	Sewer Drainage Basin #3	No		2	2	3	1	1	1.60	1969	51	24	4		0	4	6.4
3441	3397	CP	8	6.75	6.4	378.8	Sewer Drainage Basin #3	No		2	2	3	1	1	1.60	1969	51	24	4		0	4	6.4
3442-CO	3441	CP	8	0	6.75	261.5	Sewer Drainage Basin #3	No		2	2	3	1	1	1.60	1969	51	24	4		0	4	6.4
2267	2191	CP	8	7.5	8.67	380.9	Sewer Drainage Basin #2	No		2	2	3	1	1	1.60	1941	79	-4	6	4136	4	4	6.4
5067	5066	CP	8	9	6	170.9	Sewer Drainage Basin #5	No		2	2	3	1	1	1.60	1973	47	28	4		0	4	6.4
5066	5061	CP	8	6.1	6.5	263.5	Sewer Drainage Basin #5	No		2	2	3	1	1	1.60	1973	47	28	4		0	4	6.4
5060	5108	CP	8	8	7.33	31.1	Sewer Drainage Basin #5	No		2	2	3	1	1	1.60	1973	47	28	4		0	4	6.4
5083-CO	5060	CP	8	0	8	153.8	Sewer Drainage Basin #5	No		2	2	3	1	1	1.60	1973	47	28	4		0	4	6.4
2275	2270	CP	8	7.05	8.4	149.6	Sewer Drainage Basin #2	No		2	2	3	1	1	1.60	1941	79	-4	6	4131	4	4	6.4
1398	1399	CP	8	8.3	8.3	250.4	Sewer Drainage Basin #1	No		2	2	3	1	1	1.60	1969	51	24	4		0	4	6.4
1399	1400	CP	8	8.3	6.8	244.3	Sewer Drainage Basin #1	No		2	2	3	1	1	1.60	1969	51	24	4		0	4	6.4
1501-CO	1502	PVC	8	0	6.08	83.1	Sewer Drainage Basin #1B	No		2	2	3	1	1	1.60	1972	48	27	4		0	4	6.4
3342	3341	CP	8	8.17	9.42	238.1	Sewer Drainage Basin #3	No		2	2	3	1	1	1.60	1969	51	24	4		0	4	6.4
3346	3342	CP	8	7.67	8.17	246.1	Sewer Drainage Basin #3	No		2	2	3	1	1	1.60	1969	51	24	4		0	4	6.4
3401	3400	CP	8	5.25	6.75	247.1	Sewer Drainage Basin #3	No		2	2	3	1	1	1.60	1969	51	24	4		0	4	6.4
3110	3109	CP	8	7	7.42	247.8	Sewer Drainage Basin #3	No		2	2	3	1	1	1.60	1969	51	24	4	4131	4	4	6.4
3219	3208	CP	8	9.58	7.83	309.5	Sewer Drainage Basin #3	No		2	2	3	1	1	1.60	1969	51	24	4		0	4	6.4
4411-CO	4107	PVC	8	0	9.7	156.9	Sewer Drainage Basin #4	No		2	2	3	1	1	1.60	1974	46	29	4	4134	4	4	6.4
2055	2054	CP	8	3.83	7	180.1	Sewer Drainage Basin #2	No		2	2	3	1	1	1.60	1941	79	-4	6	4131	4	4	6.4
3489	3488	PVC	8	6.33	7	153.2	Sewer Drainage Basin #3	No		2	2	3	1	1	1.60	1969	51	24	4		0	4	6.4
3531	3161	CP	8	8.35	8.9	232.8	Sewer Drainage Basin #3	No		2	2	3	1	1	1.60	1969	51	24	4	4100	4	4	6.4
1572	1166	CP	8	5.92	8	339.3	Sewer Drainage Basin #1	No		2	2	3	1	1	1.60	1963	57	18	5	4132	4	4	6.4
1484	1472	CP	8	6.4	6.6	311.7	Sewer Drainage Basin #1B	No		2	2	3	1	1	1.60	1972	48	27	4		0	4	6.4
1485	1484	CP	8	7.1	6.4	146.5	Sewer Drainage Basin #1B	No		2	2	3	1	1	1.60	1972	48	27	4		0	4	6.4
1431	1430	CP	8	7.6	6.2	264.6	Sewer Drainage Basin #1B	No		2	2	3	1	1	1.60	1972	48	27	4		0	4	6.4
1432	1431	CP	8	8.6	7.6	250.3	Sewer Drainage Basin #1B	No		2	2	3	1	1	1.60	1972	48	27	4		0	4	6.4
1490	1432	CP	8	7.5	8.6	172.8	Sewer Drainage Basin #1B	No		2	2	3	1	1	1.60	1972	48	27	4		0	4	6.4
1472	1471	CP	8	6.6	6.7	252.0	Sewer Drainage Basin #1B	No		2	2	3	1	1	1.60	1972	48	27	4		0	4	6.4
1473	1472	CP	8	6.6	6.6	143.5	Sewer Drainage Basin #1B	No		2	2	3	1	1	1.60	1972	48	27	4		0	4	6.4
1474	1473	CP	8	6.7	6.6	87.1	Sewer Drainage Basin #1B	No		2	2	3	1	1	1.60	1972	48	27	4		0	4	6.4
1488-CO	1473	CP	8	0	6.6	217.4	Sewer Drainage Basin #1B	No		2	2	3	1	1	1.60	1972	48	27	4		0	4	6.4
3044	3043	CP	8	8.67	9.25	194.7	Sewer Drainage Basin #3	No		2	2	3	1	1	1.60	1969	51	24	4		0	4	6.4
1442	1441	PVC	8	7.8	5.6	246.1	Sewer Drainage Basin #1B	No		2	2	3	1	1	1.60	1972	48	27	4		0	4	6.4
1443	1442	PVC	8	7.7	7.8	67.4	Sewer Drainage Basin #1B	No		2	2	3	1	1	1.60	1972	48	27	4		0	4	6.4
1434	1433	PVC	8	6.8	7.4	297.8	Sewer Drainage Basin #1B	No		2	2	3	1	1	1.60	1972	48	27	4		0	4	6.4
1435	1434	PVC	8	6.4	6.8	76.7	Sewer Drainage Basin #1B	No		2	2	3	1	1	1.60	1972	48	27	4		0	4	6.4
1512	1511	CP	8	5.9	6	85.0	Sewer Drainage Basin #1B	No		2	2	3	1	1	1.60	1972	48	27	4		0	4	6.4
5068-CO	5067	CP	8	0	9	137.3	Sewer Drainage Basin #5	No		2	2	3	1	1	1.60	1973	47	28	4		0	4	6.4
1457-CO	1456	CP	8	0	8.1	45.5	Sewer Drainage Basin #1B	No		2	2	3	1	1	1.60	1972	48	27	4		0	4	6.4
1526-CO	1456	CP	8	0	8.1	61.3	Sewer Drainage Basin #1B	No		2	2	3	1	1	1.60	1972	48	27	4		0	4	6.4
1176	1926	CP	8	6.15	9	247.6	Sewer Drainage Basin #1	No		2	2	3	1	1	1.60	1963	57	18	5	412E	4	4	6.4
1454-CO	1453	CP	8	0	9.33	47.5	Sewer Drainage Basin #1B	No		2	2	3	1	1	1.60	1972	48	27	4		0	4	6.4
3909	3258	CP	8	7	9.25	138.8	Sewer Drainage Basin #3	No		2	2	3	1	1	1.60	1969	51	24	4		0	4	6.4
3237	3236	CP	8	7.33	7.67	212.6	Sewer Drainage Basin #3	No		2	2	3	1	1	1.60	1969	51	24	4		0	4	6.4
1463	1462	XXX	8	0	7.42	225.7	Sewer Drainage Basin #1B	No		2	2	3	1	1	1.60	1972	48	27	4		0	4	6.4
1489-CO	1430	CP	8	0	6.2	205.1	Sewer Drainage Basin #1B	No		2	2	3	1	1	1.60	1972	48	27	4		0	4	6.4
3390-CO	3375	CP	8	0	6.5	176.2	Sewer Drainage Basin #3	No		2	2	3	1	1	1.60	1969	51	24	4	4131	4	4	6.4
2064-CO	2063	CP	8	0	6.67	224.7	Sewer Drainage Basin #2	No		2	2	3	1	1	1.60	1941	79	-4	6	413G	4	4	6.4
1733	1499	CP	8	9	8.5	16.0	Sewer Drainage Basin #1B	No		2	2	3	1	1	1.60	1972	48	27	4		0	4	6.4
3938	3531	PVC	8	9.3	8.33	94.4	Sewer Drainage Basin #3	No		2	2	3	1	1	1.60	1969	51	24	4		0	4	6.4
2188	2151	CP	8	9.33	16.91	347.3	Sewer Drainage Basin #2	No		2	4	5	1	1	2.10	1941	79	-4	6	3323	3	3	6.3
3358	3357	CP	10	8	6	207.9	Sewer Drainage Basin #3	No		3	2	5	1	1	2.10	1968	52	23	5	3100	3	3	6.3
3360	3359	CP	10	7.58	8.08	295.0	Sewer Drainage Basin #3	No		3	2	5	1	1	2.10	1969	51	24	4	2A11	3	3	6.3
2227	2226	CP	10	12.58	13.25	313.8	Sewer Drainage Basin #2	No	Root-X	3	3	4	1	2	2.10	1941	79	-4	6	3321	3	3	6.3
3338	3166	CP	8	6.11	14.2	388.9	Sewer Drainage Basin #3	No		2	4	5	1	1	2.10	1969	51	24	4	2900	3	3	6.3
4078	4077	CP	8	6.4	3.6	159.1	Sewer Drainage Basin #4	No		2	2	1	1	6	1.55	1974	46	29	4				

UNITID	UNITID2	MATERIAL	DIAMETER	UP DEPTH	DOWN DEPTH	PIPE LENGTH	Drainage Basin	Backbone Pipe	Quarterly Maintenance	Pipe Diameter COF	Pipe Depth COF	Road Type COF	Seismic Backbone COF	Impact on Water Bodies COF	Weighted COF	Estimated Install Year	Estimated Pipe Age	Estimated Remaining Useful Life	LOF Based on Remaining Useful Life	PACP Quick Score (Overall)	PACP Based LOF (Rounded)	Final LOF	Risk
5020	5019	CP	8	3.83	9	360.6	Sewer Drainage Basin #5	No		2	2	1	1	6	1.55	1973	47	28	4		0	4	6.2
5021	5020	XXX	8	8	0	361.8	Sewer Drainage Basin #5	No		2	2	1	1	6	1.55	1973	47	28	4		0	4	6.2
5023	5022	XXX	8	8.1	8.17	371.2	Sewer Drainage Basin #5	No		2	2	1	1	6	1.55	1973	47	28	4		0	4	6.2
5022	5021	CP	8	8.17	8	357.2	Sewer Drainage Basin #5	No		2	2	1	1	6	1.55	1973	47	28	4		0	4	6.2
4025	4008	CP	8	2	7.6	176.6	Sewer Drainage Basin #4	No		2	2	1	1	6	1.55	1974	46	29	4		0	4	6.2
4511	4036	CP	8	7	6.5	94.0	Sewer Drainage Basin #4	No		2	2	1	1	6	1.55	1974	46	29	4	4100	4	4	6.2
4086	4085	CP	8	5.7	6.55	81.2	Sewer Drainage Basin #4	No		2	2	1	1	6	1.55	1974	46	29	4	4100	4	4	6.2
1497	1441	PVC	8	3.8	5.6	343.4	Sewer Drainage Basin #1B	No		2	1	3	1	2	1.55	1972	48	27	4		0	4	6.2
1513	1512	CP	8	5.8	5.9	167.6	Sewer Drainage Basin #1B	No		2	1	3	1	2	1.55	1972	48	27	4		0	4	6.2
4085	4909	CP	8	6.55	6	120.9	Sewer Drainage Basin #4	No		2	2	1	1	6	1.55	1974	46	29	4	4111	4	4	6.2
1498-CO	1497	PVC	8	0	3.8	151.6	Sewer Drainage Basin #1B	No		2	1	3	1	2	1.55	1972	48	27	4		0	4	6.2
5040	5021	CP	8	8.9	7.8	98.9	Sewer Drainage Basin #5	No		2	2	1	1	6	1.55	1973	47	28	4		0	4	6.2
1514-CO	1513	CP	8	0	5.8	158.3	Sewer Drainage Basin #1B	No		2	1	3	1	2	1.55	1972	48	27	4		0	4	6.2
2257	2225	CP	10	6.42	12.08	348.1	Sewer Drainage Basin #2	No		3	3	4	1	1	2.05	1941	79	-4	6	2100	3	3	6.2
2223	2222	PE	12	13.3	13.4	164.2	Sewer Drainage Basin #2	No		3	3	4	1	1	2.05	2015	5	70	1	2600	3	3	6.2
2226	2225	CP	10	13.25	12.08	321.2	Sewer Drainage Basin #2	No		3	3	4	1	1	2.05	1941	79	-4	6	2H1B	3	3	6.2
2224	2223	CP	10	9.33	13.5	271.3	Sewer Drainage Basin #2	No		3	3	4	1	1	2.05	1941	79	-4	6	2F00	3	3	6.2
2225	2224	CP	10	12.25	9.33	353.6	Sewer Drainage Basin #2	No		3	3	4	1	1	2.05	1941	79	-4	6	2D11	3	3	6.2
1111	1097	PVC	8	5.3	5.75	227.0	Sewer Drainage Basin #1	No		2	1	1	1	1	1.20	1963	57	18	5		0	5	6.0
1112-CO	1111	VCP	8	0	5.6	143.2	Sewer Drainage Basin #1	No		2	1	1	1	1	1.20	1963	57	18	5		0	5	6.0
1100	1099	CP	8	3.83	4.25	118.5	Sewer Drainage Basin #1	No		2	1	1	1	1	1.20	1963	57	18	5		0	5	6.0
N1929	1929	PVC	6	0	0	0.0	Sewer Drainage Basin #1	No		2	1	1	1	1	1.20	1963	57	18	5		0	5	6.0
3484	3417	CP	8	4.83	5	230.4	Sewer Drainage Basin #3	No		2	1	3	1	1	1.50	1969	51	24	4	4131	4	4	6.0
3440	3439	CP	8	4.75	5.83	216.4	Sewer Drainage Basin #3	No		2	1	3	1	1	1.50	1969	51	24	4		0	4	6.0
2129	2019	CP	8	9.45	12.25	326.3	Sewer Drainage Basin #2	No		2	3	5	1	1	2.00	1941	79	-4	6	3124	3	3	6.0
2204	2157	CP	8	13.83	8.42	253.4	Sewer Drainage Basin #2	No		2	3	5	1	1	2.00	1941	79	-4	6	3311	3	3	6.0
1537-CO	1536	PVC	6	0	10	95.7	Sewer Drainage Basin #1B	No		1	3	3	1	1	1.50	1972	48	27	4		0	4	6.0
3085	3084	CP	10	4.75	6.33	326.2	Sewer Drainage Basin #3	No		3	2	4	1	2	2.00	1969	51	24	4	2600	3	3	6.0
4000	4515	VCP	8	7.5	7.7	86.2	Sewer Drainage Basin #4	No		2	2	1	1	5	1.50	1974	46	29	4		0	4	6.0
1189	1999	CP	8	5.75	0	271.6	Sewer Drainage Basin #1	No		2	1	3	1	1	1.50	1963	57	18	5	433H	4	4	6.0
2192	2153	CP	8	12.75	6.25	213.2	Sewer Drainage Basin #2	No		2	3	5	1	1	2.00	1941	79	-4	6	3211	3	3	6.0
3306	3305	CP	8	10	26.92	352.9	Sewer Drainage Basin #3	No		2	6	3	1	1	2.00	1969	51	24	4	2B11	3	3	6.0
4065-CO	4064	CP	6	0	10.2	61.0	Sewer Drainage Basin #4	No		1	3	3	1	1	1.50	1974	46	29	4		0	4	6.0
2913	2055	CP	6	0	0	429.8	Sewer Drainage Basin #2	No		2	1	3	1	1	1.50	1941	79	-4	6	4233	4	4	6.0
6051WW	SV1001	XXX	0	0	0	5.3	Sewer Drainage Basin #1B	No		1	1	3	1	5	1.50	1972	48	27	4		0	4	6.0
3-PUMP1_C	SV1003	XXX	0	0	0	1.4	Sewer Drainage Basin #1B	No		1	1	3	1	5	1.50	1972	48	27	4		0	4	6.0
SV1004	N6051B	XXX	0	0	0	1.4	Sewer Drainage Basin #1B	No		1	1	3	1	5	1.50	1972	48	27	4		0	4	6.0
3-PUMP2_C	SV1002	XXX	0	0	0	1.4	Sewer Drainage Basin #1B	No		1	1	3	1	5	1.50	1972	48	27	4		0	4	6.0
SV1002	N6051B	XXX	0	0	0	1.5	Sewer Drainage Basin #1B	No		1	1	3	1	5	1.50	1972	48	27	4		0	4	6.0
SV1001	5-PUMP2_0	XXX	0	0	0	1.1	Sewer Drainage Basin #1B	No		1	1	3	1	5	1.50	1972	48	27	4		0	4	6.0
SV1003	SV1004	XXX	0	0	0	1.0	Sewer Drainage Basin #1B	No		1	1	3	1	5	1.50	1972	48	27	4		0	4	6.0
SV1002	SV1005	XXX	0	0	0	1.0	Sewer Drainage Basin #1B	No		1	1	3	1	5	1.50	1972	48	27	4		0	4	6.0
1500-CO	1733	CP	8	0	0	164.2	Sewer Drainage Basin #1B	No		2	1	3	1	1	1.50	1972	48	27	4		0	4	6.0
6025	6006	PVC	8	8.8	10	18.5	Sewer Drainage Basin #6	No		2	3	5	1	1	2.00	1988	32	43	3		0	3	6.0
2920	2013	PE	8	11.11	11	284.7	Sewer Drainage Basin #2	No		2	3	5	1	1	2.00	2013	7	68	1	3126	3	3	6.0
2000	1078	PE	24	22.2	0	276.2	Sewer Drainage Basin #2	Yes		6	5	6	6	6	5.90	2011	9	66	1		0	1	5.9
1125	1124	PVC	10	5.17	4.58	254.8	Sewer Drainage Basin #1	No		3	1	3	1	6	1.95	1963	57	18	5	2F00	3	3	5.9
1185	1180	CP	8	5.75	5.33	353.2	Sewer Drainage Basin #1	No		2	1	6	1	1	1.95	1963	57	18	5	2K00	3	3	5.9
3301	3300	CP	8	16.7	14.7	399.2	Sewer Drainage Basin #3	No		2	4	4	1	1	1.95	1969	51	24	4	2D00	3	3	5.9
1998	1997	PVC	10	0	0	187.0		No		2	1	6	1	1	1.95	2017	3	72	1	342F	3	3	5.9
1999	1998	PVC	8	0	0	43.3		No		2	1	6	1	1	1.95	2017	3	72	1	2800	3	3	5.9
4082	4081	CP	8	12.33	7.7	298.1	Sewer Drainage Basin #4	No		2	3	3	1	6	1.95	1974	46	29	4	3100	3	3	5.9
4028	4027	CP	8	0	0	208.8	Sewer Drainage Basin #4	No		2	1	1	1	6	1.45	1974	46	29	4		0	4	5.8
4027	CCMH052	CP	8	0	0	62.8	Sewer Drainage Basin #4	No		2	1	1	1	6	1.45	1974	46	29	4		0	4	5.8
3-PUMP2_C	SV1012	XXX	0	0	0	1.6	Sewer Drainage Basin #3	No		1	1	4	1	1	1.45	1969	51	24	4		0	4	5.8
SV1012	SV1014	XXX	0	0	0	1.0	Sewer Drainage Basin #3	No		1	1	4	1	1	1.45	1969	51	24	4		0	4	5.8
3-PUMP1_C	SV1011	XXX	0	0	0	1.5	Sewer Drainage Basin #3	No		1	1	4	1	1	1.45	1969	51	24	4		0	4	5.8
SV1009	3-PUMP1_0	XXX	0	0	0	1.5	Sewer Drainage Basin #3	No		1	1	4	1	1	1.45	1969	51	24	4		0	4	5.8
3288	SV1009	XXX	0	0	0	10.6	Sewer Drainage Basin #3	No		1	1	4	1	1	1.45	1969	51	24	4		0	4	5.8
SV1010	3-PUMP2_0	XXX	0	0	0	1.5	Sewer Drainage Basin #3	No		1	1	4	1	1	1.45	1969	51	24	4		0	4	5.8
3288	SV1010	XXX	0	0	0	10.6	Sewer Drainage Basin #3	No		1	1	4	1	1	1.45	1969	51	24	4		0	4	5.8
1106	1111	CP	6	4.2	5.3	227.9	Sewer Drainage Basin #1	No		1	1	2	1	1	1.15	1963	57	18	5		0	5	5.8
1107	1106	PVC	6	3.55	4.2	74.2	Sewer Drainage Basin #1	No		1	1	2	1	1	1.15	1963	57	18	5		0	5	5.8
1149	1524	CP	8	4.2	4.75	81.9	Sewer Drainage Basin #1	No		1	1	2	1	1	1.15	1963	57	18	5		0	5	5.8
6003	6002	CP	8	5.1	9.5	251.8	Sewer Drainage Basin #6	No		2	2	5	1	1	1.90	1988	32	43	3		0	3	5.7
2171	2170	CP	10	9.33	10	118.0	Sewer Drainage Basin #2	No		3	3	3	1	1	1.90	1941	79	-4	6	322A	3	3	5.7
2172	2171	CP	10	7	10	117.7	Sewer Drainage Basin #2	No		3	3	3	1	1	1.90	1941	79	-4	6	2B00	3	3	5.7
2904	2155	CP	8	8.4	8.95	399.1	Sewer Drainage Basin #2	No		2	2	5	1	1	1.90	1941	79	-4	6	3100	3	3	5.7
2300	2157	CP	8	7.58	8.25	289.6	Sewer Drainage Basin #2	No		2	2	5	1	1	1.90	1941	79	-4	6	2B11	3	3	5.7
2205	2159	CP	8																				

UNITID	UNITID2	MATERIAL	DIAMETER	UP DEPTH	DOWN DEPTH	PIPE LENGTH	Drainage Basin	Backbone Pipe	Quarterly Maintenance	Pipe Diameter COF	Pipe Depth COF	Road Type COF	Seismic Backbone COF	Impact on Water Bodies COF	Weighted COF	Estimated Install Year	Estimated Pipe Age	Estimated Remaining Useful Life	LOF Based on Remaining Useful Life	PACP Quick Score (Overall)	PACP Based LOF (Rounded)	Final LOF	Risk
2159	2158	CP	8	7	7.58	282.2	Sewer Drainage Basin #2	No		2	2	5	1	1	1.90	1941	79	-4	6	2600	3	3	5.7
3337	3319	CP	10	11.33	10	299.0	Sewer Drainage Basin #3	No		3	3	3	1	1	1.90	1969	51	24	4	312A	3	3	5.7
2160	2159	CP	8	6.67	7	330.1	Sewer Drainage Basin #2	No		2	2	5	1	1	1.90	1941	79	-4	6	2G11	3	3	5.7
2154	2153	CP	8	9.33	6.33	310.1	Sewer Drainage Basin #2	No		2	2	5	1	1	1.90	1941	79	-4	6	312D	3	3	5.7
3058	3057	CP	8	8.08	9	391.8	Sewer Drainage Basin #3	No		2	2	5	1	1	1.90	1969	51	24	4	2B00	3	3	5.7
2104	2089	CP	8	9.67	19.83	294.8	Sewer Drainage Basin #2	No		2	5	3	1	1	1.90	1941	79	-4	6	2711	3	3	5.7
3455	3454	CP	8	19	6.75	274.7	Sewer Drainage Basin #3	No		2	5	3	1	1	1.90	1969	51	24	4	2A00	3	3	5.7
4007	4006	CP	8	10	11	18.6	Sewer Drainage Basin #4	No		2	3	1	1	1	1.40	1974	46	29	4		0	4	5.6
4002	4000	CP	8	7	7.5	35.7	Sewer Drainage Basin #4	No		2	2	1	1	3	1.40	1974	46	29	4		0	4	5.6
1539-CO	1535	PVC	6	0	6.66	101.1	Sewer Drainage Basin #1B	No		1	2	3	1	1	1.40	1972	48	27	4		0	4	5.6
1433	1432	CP	8	7.4	8.6	298.1	Sewer Drainage Basin #1B	No		1	2	3	1	1	1.40	1972	48	27	4		0	4	5.6
1568	1163	CP	10	9.25	9.83	395.5	Sewer Drainage Basin #1	No		1	2	3	1	1	1.40	1963	57	18	5	4234	4	4	5.6
2914	2054	CP	6	5.8	7	457.0	Sewer Drainage Basin #2	No		1	2	3	1	1	1.40	1941	79	-4	6	4232	4	4	5.6
2910	2050	CP	8	3.3	8.5	304.4	Sewer Drainage Basin #2	No		1	2	3	1	1	1.40	1941	79	-4	6	413B	4	4	5.6
4010	4057	CP	6	1	7.4	334.2	Sewer Drainage Basin #4	No		1	2	3	1	1	1.40	1900	120	-45	6	4134	4	4	5.6
2248	2223	PE	8	7.08	10.33	328.8	Sewer Drainage Basin #2	No		2	3	4	1	1	1.85	2015	5	70	1	2F00	3	3	5.6
3248	3247	CP	8	9.58	10.92	278.0	Sewer Drainage Basin #3	No		2	3	4	1	1	1.85	1969	51	24	4	2A00	3	3	5.6
3120	3119	CP	8	10.42	8.67	400.4	Sewer Drainage Basin #3	No		2	3	4	1	1	1.85	1969	51	24	4	312L	3	3	5.6
2244	2222	CP	8	11.08	13.5	120.9	Sewer Drainage Basin #2	No		2	3	4	1	1	1.85	1941	79	-4	6	2911	3	3	5.6
3189	3188	CP	8	11.17	13.83	396.3	Sewer Drainage Basin #3	No		2	3	4	1	1	1.85	1969	51	24	4	2A00	3	3	5.6
2240	2220	PE	8	9.33	13.33	336.0	Sewer Drainage Basin #2	No		2	3	4	1	1	1.85	2015	5	70	1	2D00	3	3	5.6
3290	3289	CP	8	11.5	9	379.8	Sewer Drainage Basin #3	No		2	3	4	1	1	1.85	1969	51	24	4	2A00	3	3	5.6
3291	3290	CP	8	13	11.5	141.8	Sewer Drainage Basin #3	No		2	3	4	1	1	1.85	1969	51	24	4	2A00	3	3	5.6
2370	2223	CP	8	11.7	10.33	105.5	Sewer Drainage Basin #2	No		2	3	4	1	1	1.85	1941	79	-4	6	2B00	3	3	5.6
1168	1601	CP	10	8	8.66	399.4	Sewer Drainage Basin #1	No		3	2	3	1	1	1.80	1963	57	18	5	2900	3	3	5.4
1601	1568	CP	10	8.66	9.25	400.0	Sewer Drainage Basin #1	No		3	2	3	1	1	1.80	1963	57	18	5	322D	3	3	5.4
2280	2228	CP	10	7.25	7.33	39.9	Sewer Drainage Basin #2	No		3	2	3	1	1	1.80	1941	79	-4	6	2900	3	3	5.4
3128	3127	CP	8	12.92	14.33	136.5	Sewer Drainage Basin #3	No		2	4	3	1	1	1.80	1969	51	24	4	2600	3	3	5.4
2303	2302	PVC	8	16	11.58	170.3	Sewer Drainage Basin #2	No		2	4	3	1	1	1.80	1941	79	-4	6	2700	3	3	5.4
3481	3480	CP	8	14.83	3	305.8	Sewer Drainage Basin #3	No		2	4	3	1	1	1.80	1969	51	24	4	2C00	3	3	5.4
3460	3459	CP	8	10.42	14.67	137.4	Sewer Drainage Basin #3	No		2	4	3	1	1	1.80	1969	51	24	4	2700	3	3	5.4
3286	3157	CP	8	11.83	17.67	230.3	Sewer Drainage Basin #3	No		2	4	3	1	1	1.80	1969	51	24	4	2A00	3	3	5.4
3482	3481	CP	8	7.42	14.83	276.1	Sewer Drainage Basin #3	No	Jetting Llnes	2	4	3	1	1	1.80	1969	51	24	4	312B	3	3	5.4
1230	1229	CP	8	10.5	16	159.6	Sewer Drainage Basin #1	No		2	4	3	1	1	1.80	1963	57	18	5	2J00	3	3	5.4
3049	3048	CP	8	9.67	14.42	294.5	Sewer Drainage Basin #3	No		2	4	3	1	1	1.80	1969	51	24	4	312A	3	3	5.4
2189	2188	CP	8	8.75	9.33	321.7	Sewer Drainage Basin #2	No		2	2	4	1	1	1.75	1941	79	-4	6	3222	3	3	5.3
3924	3135	CP	8	6.42	8.92	137.2	Sewer Drainage Basin #3	No		2	2	4	1	1	1.75	1969	51	24	4	3123	3	3	5.3
4510	CCMH058	CP	8	4.55	15.33	101.7	Sewer Drainage Basin #4	No		2	4	1	1	6	1.75	1974	46	29	4	3100	3	3	5.3
3923	3178	CP	6	11.5	9.9	215.8	Sewer Drainage Basin #3	No		1	3	3	1	6	1.75	1969	51	24	4	3111	3	3	5.3
2322	2321	PE	8	9.67	9.33	383.8	Sewer Drainage Basin #2	No		2	2	4	1	1	1.75	2015	5	70	1	2A00	3	3	5.3
3093	3092	CP	8	9.42	7.92	298.2	Sewer Drainage Basin #3	No		2	2	4	1	1	1.75	1969	51	24	4	3100	3	3	5.3
3201	3186	CP	8	6.92	7.2	250.1	Sewer Drainage Basin #3	No		2	2	4	1	1	1.75	1969	51	24	4	3200	3	3	5.3
2252	2246	PE	8	8.92	7.92	357.6	Sewer Drainage Basin #2	No		2	2	4	1	1	1.75	2015	5	70	1	2A00	3	3	5.3
2073	2072	CP	8	8	8.08	472.1	Sewer Drainage Basin #2	No		2	2	4	1	1	1.75	1941	79	-4	6	312A	3	3	5.3
2009	2008	PE	12	9	5.38	198.0	Sewer Drainage Basin #2	Yes		5	2	5	6	5	5.20	2013	7	68	1	0	1	1	5.2
1754	1757	CP	8	7.08	8.8	370.5	Sewer Drainage Basin #1B	No		2	2	1	1	1	1.30	1972	48	27	4		0	4	5.2
4001	4000	CP	8	3.85	5.1	10.6	Sewer Drainage Basin #4	No		2	1	1	1	3	1.30	1974	46	29	4		0	4	5.2
1533	1532	PVC	8	7.9	5.55	105.3	Sewer Drainage Basin #1B	No		2	2	1	1	1	1.30	1972	48	27	4		0	4	5.2
1577	1574	PVC	8	5.33	6.33	178.8	Sewer Drainage Basin #1B	No		2	2	1	1	1	1.30	1972	48	27	4		0	4	5.2
1574	1516	CP	8	6.6	7.3	12.1	Sewer Drainage Basin #1B	No		2	2	1	1	1	1.30	1972	48	27	4		0	4	5.2
1755	1754	CP	8	7.9	7.75	16.6	Sewer Drainage Basin #1B	No		2	2	1	1	1	1.30	1972	48	27	4		0	4	5.2
1758	1755	CP	8	9.4	7.9	125.3	Sewer Drainage Basin #1B	No		2	2	1	1	1	1.30	1972	48	27	4		0	4	5.2
3220	3219	CP	8	9.58	9.58	69.9	Sewer Drainage Basin #3	No		2	2	1	1	1	1.30	1969	51	24	4		0	4	5.2
2312-CO	2913	CP	6	0	4.08	338.8	Sewer Drainage Basin #2	No		1	1	3	1	1	1.30	1941	79	-4	6	4232	4	4	5.2
2003	2002	PE	20	18.25	20.5	124.4	Sewer Drainage Basin #2	Yes		5	5	4	6	1	5.15	2013	7	68	1		0	1	5.2
2008	2007	PE	18	5.38	2.2	149.0	Sewer Drainage Basin #2	Yes		5	1	5	6	6	5.15	2013	7	68	1	0	1	1	5.2
2002	2001	PE	20	20.5	22.7	132.5	Sewer Drainage Basin #2	Yes		5	5	4	6	1	5.15	2013	7	68	1		0	1	5.2
2924	2177	PE	8	0	0	246.0	Sewer Drainage Basin #2	No		3	1	3	1	1	1.70	2018	2	73	1	3125	3	3	5.1
1144	1143	PE	12	10	4.5	187.4	Sewer Drainage Basin #1	Yes		3	3	6	6	6	5.10	2012	8	67	1		0	1	5.1
3420	3411	CP	8	7.42	11	298.2	Sewer Drainage Basin #3	No		2	3	3	1	1	1.70	1969	51	24	4	2600	3	3	5.1
3411	3410	CP	8	11	8.83	204.3	Sewer Drainage Basin #3	No		2	3	3	1	1	1.70	1969	51	24	4	3100	3	3	5.1
3421	3412	CP	8	7.92	11.58	177.9	Sewer Drainage Basin #3	No		2	3	3	1	1	1.70	1969	51	24	4	3100	3	3	5.1
3412	3493	CP	8	11.58	11.58	59.2	Sewer Drainage Basin #3	No		2	3	3	1	1	1.70	1969	51	24	4	2A00	3	3	5.1
2259	2258	CP	8	6.33	12.67	400.8	Sewer Drainage Basin #2	No		2	3	3	1	1	1.70	1941	79	-4	6	3100	3	3	5.1
2254	2922	PE	8	12.05	7.58	362.6	Sewer Drainage Basin #2	No		2	3	3	1	1	1.70	2015	5	70	1	2F00	3	3	5.1
2249	2248	PE	8	11.42	7.42	370.8	Sewer Drainage Basin #2	No		2	3	3	1	1	1.70	2015	5	70	1	2L00	3	3	5.1
2037	2036	PE	8	10.33	10.2	381.3	Sewer Drainage Basin #2	No		2	3	3	1	1	1.70	2018	2	73	1	342E	3	3	5.1
2193	2192	CP	8	9.75	12.75	330.2	Sewer Drainage Basin #2	No		2	3	3	1	1</									



UNITID	UNITID2	MATERIAL	DIAMETER	UP DEPTH	DOWN DEPTH	PIPE LENGTH	Drainage Basin	Backbone Pipe	Quarterly Maintenance	Pipe Diameter COF	Pipe Depth COF	Road Type COF	Seismic Backbone COF	Impact on Water Bodies COF	Weighted COF	Estimated Install Year	Estimated Pipe Age	Estimated Remaining Useful Life	LOF Based on Remaining Useful Life	PACP Quick Score (Overall)	PACP Based LOF (Rounded)	Final LOF	Risk
3285	3280	CP	8	8	13	352.1	Sewer Drainage Basin #3	No		2	3	3	1	1	1.70	1969	51	24	4	2800	3	3	5.1
3250	3249	CP	8	9.67	10.08	425.8	Sewer Drainage Basin #3	No		2	3	3	1	1	1.70	1969	51	24	4	2800	3	3	5.1
3223	3222	CP	8	10.92	11.17	195.1	Sewer Drainage Basin #3	No		2	3	3	1	1	1.70	1969	51	24	4	2700	3	3	5.1
3339	3199	CP	8	11.17	10.58	309.9	Sewer Drainage Basin #3	No		2	3	3	1	1	1.70	1969	51	24	4	2C00	3	3	5.1
3116	3115	CP	8	9.33	12.58	520.2	Sewer Drainage Basin #3	No		2	3	3	1	1	1.70	1969	51	24	4	312C	3	3	5.1
3214	3213	CP	8	13.33	8.83	499.3	Sewer Drainage Basin #3	No		2	3	3	1	1	1.70	1969	51	24	4	2D00	3	3	5.1
2230	2229	CP	8	5.5	11	289.0	Sewer Drainage Basin #2	No		2	3	3	1	1	1.70	1941	79	-4	6	2F00	3	3	5.1
3506	3097	CP	8	10	8.92	294.2	Sewer Drainage Basin #3	No		2	3	3	1	1	1.70	1969	51	24	4	3111	3	3	5.1
4103	4063	CP	8	13.2	7	249.9	Sewer Drainage Basin #4	No		2	3	3	1	1	1.70	1974	46	29	4	2800	3	3	5.1
4104	4103	CP	8	10	13.2	200.2	Sewer Drainage Basin #4	No		2	3	3	1	1	1.70	1974	46	29	4	312A	3	3	5.1
3129	3128	CP	8	9.92	12.92	148.5	Sewer Drainage Basin #3	No		2	3	3	1	1	1.70	1969	51	24	4	2C00	3	3	5.1
2023	2213	CP	8	5.5	10.75	265.6	Sewer Drainage Basin #2	No		2	3	3	1	1	1.70	1941	79	-4	6	2A00	3	3	5.1
2201-CO	2192	CP	8	0	12.75	118.8	Sewer Drainage Basin #2	No		2	3	3	1	1	1.70	1941	79	-4	6	3100	3	3	5.1
5065-CO	5064	CP	8	0	10.25	108.7	Sewer Drainage Basin #5	No		2	3	3	1	1	1.70	1973	47	28	4	3121	3	3	5.1
2281	2228	CP	8	10.92	7.33	314.4	Sewer Drainage Basin #2	No		2	3	3	1	1	1.70	1960	60	15	5	3125	3	3	5.1
3336	3317	CP	8	12.5	10.92	401.1	Sewer Drainage Basin #3	No		2	3	3	1	1	1.70	1969	51	24	4	2A00	3	3	5.1
2099	2086	CP	8	7.42	12.83	402.3	Sewer Drainage Basin #2	No		2	3	3	1	1	1.70	1941	79	-4	6	2900	3	3	5.1
3323	3311	CP	8	11.5	9.1	251.6	Sewer Drainage Basin #3	No		2	3	3	1	1	1.70	1969	51	24	4	3222	3	3	5.1
3309	3902	CP	8	12.33	9.58	371.4	Sewer Drainage Basin #3	No		2	3	3	1	1	1.70	1969	51	24	4	3124	3	3	5.1
3307	3306	CP	8	12.25	10	342.3	Sewer Drainage Basin #3	No		2	3	3	1	1	1.70	1969	51	24	4	3121	3	3	5.1
3295	3294	CP	8	11.92	8.5	288.2	Sewer Drainage Basin #3	No		2	3	3	1	1	1.70	1969	51	24	4	3100	3	3	5.1
3011	3010	CP	15	18.3	18.8	194.2	Sewer Drainage Basin #3	Yes		4	5	3	6	6	5.05	1969	51	24	4	0	1	1	5.1
3014	3012	CP	15	21.58	17.08	457.7	Sewer Drainage Basin #3	Yes		4	5	3	6	6	5.05	1969	51	24	4	0	1	1	5.1
1026	1025	CP	20	5.17	5.17	440.1	Sewer Drainage Basin #1	Yes		5	1	6	6	1	5.05	1963	57	18	5	0	1	1	5.1
3017	3016	CP	15	19.08	21	445.2	Sewer Drainage Basin #3	Yes		4	5	3	6	5	5.00	1969	51	24	4	0	1	1	5.0
3018	3017	CP	18	16.92	19.08	327.0	Sewer Drainage Basin #3	Yes		4	5	3	6	5	5.00	1969	51	24	4	0	1	1	5.0
3138	3137	CP	15	10.33	8.67	356.9	Sewer Drainage Basin #3	Yes		4	3	4	6	6	5.00	1969	51	24	4	0	1	1	5.0
3012	3011	CP	15	17.08	17.75	253.1	Sewer Drainage Basin #3	Yes		4	4	3	6	6	4.95	1969	51	24	4	0	1	1	5.0
3020	3019	CP	18	16.33	17.33	243.8	Sewer Drainage Basin #3	Yes		4	4	3	6	6	4.95	1969	51	24	4	0	1	1	5.0
3021	3020	CP	18	16.33	16.33	180.4	Sewer Drainage Basin #3	Yes		4	4	3	6	6	4.95	1969	51	24	4	0	1	1	5.0
4029	4912	CP	8	9	9.5	255.8	Sewer Drainage Basin #4	No		2	2	2	1	5	1.65	1974	46	29	4	3100	3	3	5.0
3139	3138	CP	15	11.5	10.33	321.9	Sewer Drainage Basin #3	Yes		4	3	4	6	5	4.95	1969	51	24	4	0	1	1	5.0
1152	1153	PVC	8	0	5.5	135.3	Sewer Drainage Basin #1	No		2	1	4	1	1	1.65	1963	57	18	5	2D00	3	3	5.0
1154	1157	PVC	8	4.9	4.83	29.8	Sewer Drainage Basin #1	No		2	1	4	1	1	1.65	1963	57	18	5	3211	3	3	5.0
2012	2919	PE	10	10.5	6.66	372.9	Sewer Drainage Basin #2	Yes		3	3	5	6	5	4.90	2013	7	68	1	0	1	1	4.9
3023	3022	CP	18	16	19	113.0	Sewer Drainage Basin #3	Yes		4	5	3	6	3	4.90	1969	51	24	4	0	1	1	4.9
3347	3131	CP	12	3	18.7	149.3	Sewer Drainage Basin #3	Yes		3	5	5	6	1	4.90	1969	51	24	4	0	1	1	4.9
1145	1144	PE	12	10	10	20.1	Sewer Drainage Basin #1	Yes		3	3	6	6	1	4.85	2012	8	67	1	0	0	1	4.9
1027	1026	CP	20	9.5	9.25	87.5	Sewer Drainage Basin #1	Yes		5	2	4	6	1	4.85	1963	57	18	5	0	1	1	4.9
3456	3455	CP	8	18	19.75	274.5	Sewer Drainage Basin #3	No		2	5	1	1	1	1.60	1969	51	24	4	2.00E+00	3.00E+00	3	4.8
4006	4005	CP	0	11	3	14.2	Sewer Drainage Basin #4	No		1	3	1	1	1	1.20	1974	46	29	4	0	0	4	4.8
2273	2272	CP	8	8.33	6.19	176.7	Sewer Drainage Basin #2	No		2	2	3	1	1	1.60	1941	79	-4	6	3100	3	3	4.8
2113	2107	CP	8	6.83	8.92	395.4	Sewer Drainage Basin #2	No		2	2	3	1	1	1.60	1941	79	-4	6	2600	3	3	4.8
2105	2104	CP	8	4.25	9.67	300.3	Sewer Drainage Basin #2	No		2	2	3	1	1	1.60	1941	79	-4	6	2900	3	3	4.8
3438	3418	CP	8	6.17	7	270.8	Sewer Drainage Basin #3	No		2	2	3	1	1	1.60	1969	51	24	4	2A00	3	3	4.8
3388	3374	CP	8	7.58	7.67	140.7	Sewer Drainage Basin #3	No		2	2	3	1	1	1.60	1969	51	24	4	3100	3	3	4.8
3399	3398	CP	8	7.25	9.25	233.6	Sewer Drainage Basin #3	No		2	2	3	1	1	1.60	1969	51	24	4	2900	3	3	4.8
3398	3397	CP	8	9.25	9.25	245.9	Sewer Drainage Basin #3	No		2	2	3	1	1	1.60	1969	51	24	4	3127	3	3	4.8
3444	3353	CP	8	8.75	9	219.2	Sewer Drainage Basin #3	No		2	2	3	1	1	1.60	1969	51	24	4	3121	3	3	4.8
3446	3356	CP	8	7	7.5	238.8	Sewer Drainage Basin #3	No		2	2	3	1	1	1.60	1969	51	24	4	2800	3	3	4.8
3428-CO	3427	CP	8	4	8.75	236.3	Sewer Drainage Basin #3	No		2	2	3	1	1	1.60	1969	51	24	4	3124	3	3	4.8
3434	3431	CP	8	6.8	6.6	111.3	Sewer Drainage Basin #3	No		2	2	3	1	1	1.60	1969	51	24	4	3121	3	3	4.8
3432	3431	CP	8	5.9	6.6	184.3	Sewer Drainage Basin #3	No		2	2	3	1	1	1.60	1969	51	24	4	2A00	3	3	4.8
3418	3417	CP	8	7	5	297.9	Sewer Drainage Basin #3	No		2	2	3	1	1	1.60	1969	51	24	4	2F00	3	3	4.8
2260	2259	CP	8	8.33	6.33	333.8	Sewer Drainage Basin #2	No		2	2	3	1	1	1.60	1941	79	-4	6	312B	3	3	4.8
2179	2180	PE	8	4.83	8	267.1	Sewer Drainage Basin #2	No		2	2	3	1	1	1.60	2015	5	70	1	2900	3	3	4.8
2191	2190	CP	8	0	8.58	271.1	Sewer Drainage Basin #2	No		2	2	3	1	1	1.60	1941	79	-4	6	3122	3	3	4.8
2231	2230	CP	8	5	6	309.6	Sewer Drainage Basin #2	No		2	2	3	1	1	1.60	1941	79	-4	6	2D00	3	3	4.8
2234	2233	CP	8	6.35	8.2	176.4	Sewer Drainage Basin #2	No		2	2	3	1	1	1.60	1941	79	-4	6	3121	3	3	4.8
2198	2904	CP	8	5.58	8.25	130.4	Sewer Drainage Basin #2	No		2	2	3	1	1	1.60	1941	79	-4	6	3200	3	3	4.8
1456	1455	CP	8	8.1	8	355.2	Sewer Drainage Basin #1B	No		2	2	3	1	1	1.60	1972	48	27	4	3300	3	3	4.8
2209	2208	CP	8	7.75	9.67	169.9	Sewer Drainage Basin #2	No		2	2	3	1	1	1.60	1941	79	-4	6	2800	3	3	4.8
4097	4096	CP	8	8.5	8.8	135.7	Sewer Drainage Basin #4	No		2	2	3	1	1	1.60	1974	46	29	4	2700	3	3	4.8
3227	3213	CP	8	8.33	8.83	336.6	Sewer Drainage Basin #3	No		2	2	3	1	1	1.60	1969	51	24	4	2A00	3	3	4.8
3230	3229	CP	8	9.5	6.25	365.0	Sewer Drainage Basin #3	No		2	2	3	1	1	1.60	1969	51	24	4	2C00	3	3	4.8
3343	3342	CP	8	7.42	8.17	218.9	Sewer Drainage Basin #3	No		2	2	3	1	1	1.60	1969	51	24	4	2800	3	3	4.8
3130	3049	CP	8	7	9.67	214.2	Sewer Drainage Basin #3	No		2	2	3	1	1	1.60	1969	51	24	4	2F00	3	3	4.8
3111	3110	CP	8	7.17	7	256.7	Sewer Drainage Basin #																



UNITID	UNITID2	MATERIAL	DIAMETER	UP DEPTH	DOWN DEPTH	PIPE LENGTH	Drainage Basin	Backbone Pipe	Quarterly Maintenance	Pipe Diameter COF	Pipe Depth COF	Road Type COF	Seismic Backbone COF	Impact on Water Bodies COF	Weighted COF	Estimated Install Year	Estimated Pipe Age	Estimated Remaining Useful Life	LOF Based on Remaining Useful Life	PACP Quick Score (Overall)	PACP Based LOF (Rounded)	Final LOF	Risk
3392	3352	CP	8	8.8	8	194.2	Sewer Drainage Basin #3	No		2	2	3	1	1	1.60	1969	51	24	4	3100	3	3	4.8
3015	3014	CP	15	21.25	21.58	160.4	Sewer Drainage Basin #3	Yes		4	5	3	6	1	4.80	1969	51	24	4	0	1	1	4.8
3016	3015	CP	15	21	21.25	194.1	Sewer Drainage Basin #3	Yes		4	5	3	6	1	4.80	1969	51	24	4	0	1	1	4.8
3019	3018	CP	18	17.66	17.66	103.5	Sewer Drainage Basin #3	Yes		4	4	3	6	3	4.80	1969	51	24	4	0	1	1	4.8
3483	3482	CP	8	5.42	7.42	151.3	Sewer Drainage Basin #3	No	Jetting Llnes	2	2	3	1	1	1.60	1969	51	24	4	2911	3	3	4.8
2132	2131	CP	8	8.92	9.75	426.0	Sewer Drainage Basin #2	No		2	2	3	1	1	1.60	1941	79	-4	6	3221	3	3	4.8
2321	2320	PE	8	9.33	6.92	124.8	Sewer Drainage Basin #2	No		2	2	3	1	1	1.60	2015	5	70	1	2700	3	3	4.8
3095	3094	CP	8	8	9.17	188.5	Sewer Drainage Basin #3	No		2	2	3	1	1	1.60	1969	51	24	4	2A11	3	3	4.8
3050	3049	CP	8	5.5	9.67	213.4	Sewer Drainage Basin #3	No		2	2	3	1	1	1.60	1969	51	24	4	312D	3	3	4.8
3276	3275	CP	8	9.58	5.58	219.0	Sewer Drainage Basin #3	No		2	2	3	1	1	1.60	1969	51	24	4	2700	3	3	4.8
3231	3916	CP	8	9.17	9.25	197.7	Sewer Drainage Basin #3	No		2	2	3	1	1	1.60	1969	51	24	4	2A00	3	3	4.8
3916	3228	CP	8	9.25	6.25	219.5	Sewer Drainage Basin #3	No		2	2	3	1	1	1.60	1969	51	24	4	2C00	3	3	4.8
3430	3426	CP	8	8.5	8.83	49.5	Sewer Drainage Basin #3	No		2	2	3	1	1	1.60	1969	51	24	4	3127	3	3	4.8
3325-CO	3324	CP	8	3.5	8.5	118.4	Sewer Drainage Basin #3	No		2	2	3	1	1	1.60	1969	51	24	4	2600	3	3	4.8
3501-CO	3130	CP	8	0	7	156.9	Sewer Drainage Basin #3	No		2	2	3	1	1	1.60	1969	51	24	4	312E	3	3	4.8
4004	4003	CP	6	6	6.5	16.1	Sewer Drainage Basin #4	No		1	2	1	1	3	1.20	1974	46	29	4		0	4	4.8
4003	4002	CP	8	6.25	7	32.8	Sewer Drainage Basin #4	No		1	2	1	1	3	1.20	1974	46	29	4		0	4	4.8
3345	3341	CP	8	9	8.42	246.4	Sewer Drainage Basin #3	No		2	2	3	1	1	1.60	1969	51	24	4	2800	3	3	4.8
2011	2212	CP	8	13.93	5.92	206.2	Sewer Drainage Basin #2	Yes		2	3	5	6	6	4.75	1941	79	-4	6	0	1	1	4.8
3140	3139	CP	15	8.65	11.5	334.4	Sewer Drainage Basin #3	Yes		4	3	4	6	1	4.75	1969	51	24	4	0	1	1	4.8
3009	3008	CP	15	21.17	17.5	302.7	Sewer Drainage Basin #3	Yes		4	5	1	6	6	4.75	1969	51	24	4	0	1	1	4.8
3010	3009	CP	15	18.8	21.17	258.3	Sewer Drainage Basin #3	Yes		4	5	1	6	6	4.75	1969	51	24	4	0	1	1	4.8
2141	2140	PE	12	6.33	10.33	129.7	Sewer Drainage Basin #2	Yes		3	3	5	6	2	4.75	2013	7	68	1		0	1	4.8
3007	3006	CP	15	17.5	19.25	296.8	Sewer Drainage Basin #3	Yes		4	5	1	6	6	4.75	1969	51	24	4	0	1	1	4.8
3134	3133	CP	15	9.17	10.17	349.7	Sewer Drainage Basin #3	Yes		4	3	4	6	1	4.75	1969	51	24	4	0	1	1	4.8
3133	3132	CP	15	9.4	10	66.2	Sewer Drainage Basin #3	Yes		4	3	4	6	1	4.75	1969	51	24	4	0	1	1	4.8
3132	3515	CP	15	10	9	303.7	Sewer Drainage Basin #3	Yes		4	3	4	6	1	4.75	1969	51	24	4	0	1	1	4.8
3930	3932	CP	10	14.5	10.6	327.7	Sewer Drainage Basin #3	Yes	Jetting Llnes	3	4	3	6	6	4.75	1969	51	24	4	0	1	1	4.8
2001	2371	PE	26	22.7	22.74	21.1	Sewer Drainage Basin #2	Yes		3	5	4	6	1	4.75	2013	7	68	1		0	1	4.8
2137	2001	PE	12	15	18.8	307.0	Sewer Drainage Basin #2	Yes		3	5	4	6	1	4.75	2013	7	68	1		0	1	4.8
2013	2012	PE	10	11	10.5	257.5	Sewer Drainage Basin #2	Yes		3	3	5	6	1	4.70	2013	7	68	1		0	1	4.7
3024	3023	CP	15	13.67	16	305.5	Sewer Drainage Basin #3	Yes		4	4	3	6	1	4.70	1969	51	24	4	1100	1	1	4.7
2143	2142	PE	12	10.5	10.41	451.4	Sewer Drainage Basin #2	Yes		3	3	5	6	1	4.70	2018	2	73	1	0	1	1	4.7
2144	2143	PE	12	9.1	13.2	220.7	Sewer Drainage Basin #2	Yes		3	3	5	6	1	4.70	2018	2	73	1	0	1	1	4.7
2900	2218	PE	12	8.92	8.25	323.4	Sewer Drainage Basin #2	Yes		3	2	4	6	6	4.70	2015	5	70	1	0	1	1	4.7
2147	2146	CP	12	13.67	13.83	9.6	Sewer Drainage Basin #2	Yes		3	3	5	6	1	4.70	1941	79	-4	6	0	1	1	4.7
3137	3136	CP	15	8.67	7.42	136.1	Sewer Drainage Basin #3	Yes		4	2	4	6	2	4.70	1969	51	24	4	0	1	1	4.7
3931	3930	PVC	10	10.7	15.2	327.7	Sewer Drainage Basin #3	Yes	Jetting Llnes	2	4	4	6	6	4.70	2007	13	62	2	0	1	1	4.7
2140	2138	PE	12	10.66	6.19	344.8	Sewer Drainage Basin #2	Yes		2	3	5	6	5	4.70	2013	7	68	1		0	1	4.7
3077	3035	CP	10	13.5	10.5	368.3	Sewer Drainage Basin #3	Yes		3	3	3	6	6	4.65	1969	51	24	4	0	1	1	4.7
3141	3140	CP	15	7.9	9.25	237.5	Sewer Drainage Basin #3	Yes		4	2	4	6	1	4.65	1969	51	24	4	0	1	1	4.7
3008	3007	CP	15	16.67	17.5	200.1	Sewer Drainage Basin #3	Yes		4	4	1	6	6	4.65	1969	51	24	4	0	1	1	4.7
2323	2221	PE	12	14.16	14.16	28.5	Sewer Drainage Basin #2	Yes		3	4	4	6	1	4.65	2015	5	70	1	0	1	1	4.7
4913	4054	CP	8	7.35	18.8	82.1	Sewer Drainage Basin #4	Yes		2	5	3	6	6	4.65	1974	46	29	4	0	1	1	4.7
4077	CCMH056	PVC	8	7.7	8	82.2	Sewer Drainage Basin #4	No		2	2	1	1	6	1.55	1974	46	29	4	3121	3	3	4.7
3136	3135	CP	15	9	9.17	207.1	Sewer Drainage Basin #3	Yes		4	2	4	6	1	4.65	1969	51	24	4	0	1	1	4.7
3135	3134	CP	15	9.17	9.17	150.4	Sewer Drainage Basin #3	Yes		4	2	4	6	1	4.65	1969	51	24	4	0	1	1	4.7
3914	3913	CP	8	10	7.67	109.9	Sewer Drainage Basin #3	No		2	3	2	1	1	1.55	1969	51	24	4	2700	3	3	4.7
3022	3021	CP	18	19	16.33	178.0	Sewer Drainage Basin #3	Yes		2	5	3	6	6	4.65	1969	51	24	4	0	1	1	4.7
3217-CO	3216	CP	6	0	9.25	103.3	Sewer Drainage Basin #3	No		1	2	3	1	4	1.55	1969	51	24	4	2700	3	3	4.7
2212	2921	CP	8	5.9	6.15	6.8	Sewer Drainage Basin #2	Yes		2	2	5	6	5	4.60	1941	79	-4	6	0	1	1	4.6
3027	3026	CP	15	11.83	13.17	62.7	Sewer Drainage Basin #3	Yes		4	3	3	6	1	4.60	1969	51	24	4	0	1	1	4.6
3030	3029	CP	15	11.5	11.17	111.2	Sewer Drainage Basin #3	Yes		4	3	3	6	1	4.60	1969	51	24	4	0	1	1	4.6
3031	3030	CP	15	12.5	11.5	270.3	Sewer Drainage Basin #3	Yes		4	3	3	6	1	4.60	1969	51	24	4	0	1	1	4.6
2145	2144	PE	12	8.5	9.83	122.2	Sewer Drainage Basin #2	Yes		3	2	5	6	1	4.60	2018	2	73	1	0	1	1	4.6
3524	3523	PVC	8	15.7	16.6	204.5	Sewer Drainage Basin #3	Yes		2	4	5	6	1	4.60	1969	51	24	4	0	1	1	4.6
3028	3027	CP	15	12.5	11.83	60.9	Sewer Drainage Basin #3	Yes		4	3	3	6	1	4.60	1969	51	24	4	0	1	1	4.6
1103	1102	VCP	6	2.85	4.6	413.3	Sewer Drainage Basin #1	No		1	1	2	1	1	1.15	1963	57	18	5	3012	4	4	4.6
3350	3349	CP	8	5.67	7.4	133.5	Sewer Drainage Basin #3	Yes		2	2	5	6	5	4.60	1969	51	24	4	0	1	1	4.6
3932	3509	PVC	12	10.94	10.55	118.5	Sewer Drainage Basin #3	Yes		3	3	3	6	5	4.60	1969	51	24	4	0	1	1	4.6
2921	2009	PE	12	6.15	8.6	237.5	Sewer Drainage Basin #2	Yes		2	2	5	6	5	4.60	2013	7	68	1	0	1	1	4.6
2216	2003	PE	12	6.6	10	276.5	Sewer Drainage Basin #2	Yes		3	3	4	6	1	4.55	2013	7	68	1	0	1	1	4.6
3147	3146	CP	12	5.33	7.17	42.7	Sewer Drainage Basin #3	Yes		3	2	4	6	3	4.55	1969	51	24	4	0	1	1	4.6
2220	2219	PE	12	13.33	13	250.1	Sewer Drainage Basin #2	Yes		3	3	4	6	1	4.55	2015	5	70	1	0	1	1	4.6
2236	2216	PE	8	6.9	12.5	181.0	Sewer Drainage Basin #2	Yes		3	3	4	6	1	4.55	2013	7	68	1	0	1	1	4.6
2217	2216	PE	12	8.25	12.5	347.3	Sewer Drainage Basin #2	Yes		3	3	4	6	1	4.55	2013	7	68	1	0	1	1	4.6
2221	2220	PE	12	13.25	13.33	207.8	Sewer Drainage Basin #2	Yes		3	3	4	6	1	4.55	2015	5	70	1	0	1	1	4.6
3150	3149	CP	12	14.42	12.5	258.0	Sewer Drainage Basin #3	Yes		3	4												

UNITID	UNITID2	MATERIAL	DIAMETER	UP DEPTH	DOWN DEPTH	PIPE LENGTH	Drainage Basin	Backbone Pipe	Quarterly Maintenance	Pipe Diameter COF	Pipe Depth COF	Road Type COF	Seismic Backbone COF	Impact on Water Bodies COF	Weighted COF	Estimated Install Year	Estimated Pipe Age	Estimated Remaining Useful Life	LOF Based on Remaining Useful Life	PACP Quick Score (Overall)	PACP Based LOF (Rounded)	Final LOF	Risk
3163	3162	CP	8	9.11	11	260.4	Sewer Drainage Basin #3	Yes		2	3	5	6	1	4.50	1969	51	24	4	0	1	1	4.5
2341-CO	2911	CP	6	0	5.67	318.7	Sewer Drainage Basin #2	No		2	1	3	1	1	1.50	1941	79	-4	6	321C	3	3	4.5
2176	2926	PE	8	4.33	4.5	173.6	Sewer Drainage Basin #2	No		2	1	3	1	1	1.50	2018	2	73	1	2A00	3	3	4.5
3509	3510	PVC	12	10.5	10.75	401.8	Sewer Drainage Basin #3	Yes		3	3	3	6	2	4.45	1969	51	24	4	0	1	1	4.5
3144	3143	CP	12	8.5	8.33	334.6	Sewer Drainage Basin #3	Yes		3	2	4	6	1	4.45	1969	51	24	4	0	1	1	4.5
3145	3144	CP	12	8	8.5	37.9	Sewer Drainage Basin #3	Yes		3	2	4	6	1	4.45	1969	51	24	4	0	1	1	4.5
2083	2310	CP	10	7.55	8.1	18.8	Sewer Drainage Basin #2	Yes		3	2	4	6	1	4.45	1941	79	-4	6	0	1	1	4.5
3142	3141	CP	12	9	7.83	237.2	Sewer Drainage Basin #3	Yes		3	2	4	6	1	4.45	1969	51	24	4	0	1	1	4.5
3303	3299	CP	8	13.9	17	135.8	Sewer Drainage Basin #3	Yes		2	4	4	6	1	4.45	1969	51	24	4	0	1	1	4.5
3299	3298	CP	8	17.1	12.3	345.8	Sewer Drainage Basin #3	Yes		2	4	4	6	1	4.45	1969	51	24	4	0	1	1	4.5
2919	2921	PE	10	8.55	6.15	222.0	Sewer Drainage Basin #2	Yes		1	2	5	6	6	4.45	2013	7	68	1	0	1	1	4.5
3376	3375	CP	8	6.83	6.5	131.2	Sewer Drainage Basin #3	Yes		2	2	5	6	1	4.40	1969	51	24	4	0	1	1	4.4
3153	3152	CP	12	11.33	11.5	35.9	Sewer Drainage Basin #3	Yes		3	3	3	6	1	4.40	1969	51	24	4	0	1	1	4.4
3154	3153	CP	12	8.5	11.33	293.0	Sewer Drainage Basin #3	Yes		3	3	3	6	1	4.40	1969	51	24	4	0	1	1	4.4
3155	3156	CP	8	8.67	20.5	298.9	Sewer Drainage Basin #3	Yes		2	5	3	6	1	4.40	1969	51	24	4	1100	1	1	4.4
3487	3148	CP	12	11.5	13	110.9	Sewer Drainage Basin #3	Yes		3	3	3	6	1	4.40	1969	51	24	4	0	1	1	4.4
3510	3033	CP	12	10.75	10.5	174.4	Sewer Drainage Basin #3	Yes		3	3	3	6	1	4.40	1969	51	24	4	0	1	1	4.4
4005	4004	CP	6	3	4	156.2	Sewer Drainage Basin #4	No		1	1	1	1	3	1.10	1974	46	29	4	0	0	4	4.4
1035	1033	CP	18	0	0	464.2	Sewer Drainage Basin #1	Yes		4	1	3	6	1	4.40	1963	57	18	5	0	1	1	4.4
1426	1425	PE	12	12.5	10.7	81.7	Sewer Drainage Basin #1B	Yes		3	3	3	6	1	4.40	2011	9	66	1	0	0	1	4.4
1425	1424	PE	12	10.8	7.7	189.5	Sewer Drainage Basin #1B	Yes		3	3	3	6	1	4.40	2011	9	66	1	0	0	1	4.4
1424	1423	PE	12	7.8	10.15	309.0	Sewer Drainage Basin #1B	Yes		3	3	3	6	1	4.40	2011	9	66	1	0	0	1	4.4
1423	1422	PE	12	10.3	11	144.7	Sewer Drainage Basin #1B	Yes		3	3	3	6	1	4.40	2011	9	66	1	0	0	1	4.4
1422	1421	PE	12	11.1	10.35	279.2	Sewer Drainage Basin #1B	Yes		3	3	3	6	1	4.40	2011	9	66	1	0	0	1	4.4
2917	2137	PE	12	11.03	15	380.4	Sewer Drainage Basin #2	Yes		1	4	4	6	4	4.40	2013	7	68	1	0	0	1	4.4
1420	1419	PE	12	9.2	10.06	231.5	Sewer Drainage Basin #1B	Yes		3	3	1	6	6	4.35	2011	9	66	1	0	0	1	4.4
1419	1418	PE	12	10.23	8.45	108.6	Sewer Drainage Basin #1B	Yes		3	3	1	6	6	4.35	2011	9	66	1	0	0	1	4.4
1418	1466	PE	12	8.57	12.22	87.3	Sewer Drainage Basin #1B	Yes		3	3	1	6	6	4.35	2011	9	66	1	0	0	1	4.4
2241	2221	PE	8	0	0	402.8	Sewer Drainage Basin #2	No		1	1	4	1	1	1.45	2015	5	70	1	2D00	3	3	4.4
3063	3062	CP	10	7.5	10.33	420.2	Sewer Drainage Basin #3	No		3	3	3	1	6	2.15	1969	51	24	4	2111	2	2	4.3
3289	3159	CP	8	9	25.5	299.8	Sewer Drainage Basin #3	No		2	6	4	1	1	2.15	1969	51	24	4	2100	2	2	4.3
4036	N4031	CP	8	6.83	0	197.2	Inaccessible For Maintenance	No		2	5	1	6	6	2.15	#N/A	#N/A	#N/A	#N/A	2300	2	2	4.3
6041	N6041	PVC	12	5.8	0	29.0	Sewer Drainage Basin #6	Yes		2	1	5	6	1	4.30	2010	10	65	1	0	0	1	4.3
3041	3040	CP	8	9	6.75	166.9	Sewer Drainage Basin #3	Yes		2	2	4	6	2	4.30	1969	51	24	4	0	1	1	4.3
4914	4913	CP	8	6.75	7.35	71.7	Sewer Drainage Basin #4	Yes		2	2	3	6	5	4.30	1974	46	29	4	0	1	1	4.3
3919	3140	CP	8	4.5	8.65	20.7	Sewer Drainage Basin #3	Yes		2	2	4	6	1	4.25	1969	51	24	4	0	1	1	4.3
2218	2217	PE	12	8	8.25	526.9	Sewer Drainage Basin #2	Yes		2	2	4	6	1	4.25	2015	5	70	1	0	0	1	4.3
2138	2917	PE	12	7.2	9.06	113.9	Sewer Drainage Basin #2	Yes		1	2	4	6	5	4.25	2013	7	68	1	0	0	1	4.3
3078	3076	CP	10	6.75	9.58	426.0	Sewer Drainage Basin #3	No		3	2	4	1	4	2.10	1969	51	24	4	2100	2	2	4.2
2334	2152	CP	10	6.83	9	510.0	Sewer Drainage Basin #2	No		3	2	5	1	1	2.10	1941	79	-4	6	2414	2	2	4.2
3361	3360	CP	10	8	7.58	194.3	Sewer Drainage Basin #3	No		3	2	5	1	1	2.10	1969	51	24	4	2100	2	2	4.2
2096	2085	VCP	8	8.33	13.83	245.0	Sewer Drainage Basin #2	Yes		2	3	3	6	1	4.20	1941	79	-4	6	0	1	1	4.2
3359	3358	CP	10	8.08	8	254.0	Sewer Drainage Basin #3	No		3	2	5	1	1	2.10	1968	52	23	5	2100	2	2	4.2
3321	3320	CP	8	12.58	9.42	337.2	Sewer Drainage Basin #3	Yes		2	3	3	6	1	4.20	1969	51	24	4	0	1	1	4.2
3322	3321	CP	8	12	12.58	302.0	Sewer Drainage Basin #3	Yes		2	3	3	6	1	4.20	1969	51	24	4	0	1	1	4.2
4087	4086	CP	8	6	5.5	58.8	Sewer Drainage Basin #4	No		2	2	1	1	3	1.40	1974	46	29	4	3222	3	3	4.2
3149	3487	CP	12	12.5	11.5	284.0	Sewer Drainage Basin #3	Yes		2	3	3	6	1	4.20	1969	51	24	4	0	1	1	4.2
3167	3523	CP	8	15.67	16.5	126.9	Sewer Drainage Basin #3	No		2	4	5	1	1	2.10	1969	51	24	4	2400	2	2	4.2
3903-CO	3303	CP	8	13.8	13.9	144.8	Sewer Drainage Basin #3	Yes		2	3	3	6	1	4.20	1969	51	24	4	0	1	1	4.2
4068	4916	CP	8	11.8	12.5	135.3	Sewer Drainage Basin #4	Yes		2	3	3	6	1	4.20	1974	46	29	4	0	1	1	4.2
CB6023	PRCL082	PVC	0	10	0	5.9	Sewer Drainage Basin #6	No		2	3	1	1	1	1.40	1988	32	43	3	0	0	3	4.2
2915	2052	CP	6	5.67	8.83	264.7	Sewer Drainage Basin #2	No		1	2	3	1	1	1.40	1941	79	-4	6	311F	3	3	4.2
4063	4016	CP	8	7	9.1	302.2	Sewer Drainage Basin #4	No		1	2	3	1	1	1.40	1974	46	29	4	2800	3	3	4.2
4055	4914	CP	8	8.5	6.75	145.1	Sewer Drainage Basin #4	Yes		2	2	3	6	2	4.15	1974	46	29	4	0	1	1	4.2
3374	3373	CP	8	7.67	8.25	147.0	Sewer Drainage Basin #3	Yes		2	2	3	6	1	4.10	1969	51	24	4	0	1	1	4.1
3375	3374	CP	8	6.5	7.67	92.3	Sewer Drainage Basin #3	Yes		2	2	3	6	1	4.10	1969	51	24	4	0	1	1	4.1
3370	3369	CP	8	8.33	7	206.2	Sewer Drainage Basin #3	Yes		2	2	3	6	1	4.10	1969	51	24	4	0	1	1	4.1
3369	3368	CP	8	7	8	284.1	Sewer Drainage Basin #3	Yes		2	2	3	6	1	4.10	1969	51	24	4	0	1	1	4.1
3368	3351	CP	8	8	6.33	319.5	Sewer Drainage Basin #3	Yes		2	2	3	6	1	4.10	1969	51	24	4	0	1	1	4.1
3082	3081	CP	10	7	8.08	388.3	Sewer Drainage Basin #3	No		3	2	4	1	3	2.05	1969	51	24	4	1800	2	2	4.1
4057	4056	CP	8	7.4	8.15	40.5	Sewer Drainage Basin #4	Yes		2	2	3	6	1	4.10	1974	46	29	4	0	1	1	4.1
3070	3034	CP	8	7.3	7.1	11.7	Sewer Drainage Basin #3	Yes		2	2	3	6	1	4.10	1969	51	24	4	0	1	1	4.1
2314	2107	CP	8	5.75	8.92	62.9	Sewer Drainage Basin #2	Yes		2	2	3	6	1	4.10	1941	79	-4	6	0	1	1	4.1
4056	4055	CP	8	8.15	8.9	98.0	Sewer Drainage Basin #4	Yes		2	2	3	6	1	4.10	1974	46	29	4	0	1	1	4.1
2087	2307	CP	8	8.33	8.33	28.5	Sewer Drainage Basin #2	Yes		2	2	3	6	1	4.10	1941	79	-4	6	0	1	1	4.1
3513	3080	CP	10	7.75	6.5	127.4	Sewer Drainage Basin #3	No		3	2	4	1	3	2.05	1969	51	24	4	2200	2	2	4.1
3330	3313	CP	8	10.83	11.9	250.4	Sewer Drainage Basin #3	No		2	3	5	1	1	2.00	1969	51	24	4	2300	2	2	4.0
3365	3364	CP	8	13.25	10.75	400.8	Sewer Drainage Basin #3	No		2	3	5	1	1	2.00	1969	51	24	4	2200	2		

UNITID	UNITID2	MATERIAL	DIAMETER	UP DEPTH	DOWN DEPTH	PIPE LENGTH	Drainage Basin	Backbone Pipe	Quarterly Maintenance	Pipe Diameter COF	Pipe Depth COF	Road Type COF	Seismic Backbone COF	Impact on Water Bodies COF	Weighted COF	Estimated Install Year	Estimated Pipe Age	Estimated Remaining Useful Life	LOF Based on Remaining Useful Life	PACP Quick Score (Overall)	PACP Based LOF (Rounded)	Final LOF	Risk
3933	3525	PVC	8	7.4	9.9	68.5		No		4	2	3	1	1	2.00	2014	6	69	1	2200	2	2	4.0
2052	2050	CP	8	9.5	8.83	111.2	Sewer Drainage Basin #2	No		2	2	1	1	1	1.30	1941	79	-4	6	3125	3	3	3.9
4916	4917	CP	8	12.25	12.2	40.0	Sewer Drainage Basin #4	Yes		2	3	1	6	1	3.90	1974	46	29	4	0	1	1	3.9
1428	1427	PE	12	7.3	7.95	196.0	Sewer Drainage Basin #1B	Yes		1	2	3	6	1	3.90	2011	9	66	1		0	1	3.9
2922	2324	PE	8	0	0	240.0	Sewer Drainage Basin #2	No		1	1	3	1	1	1.30	2015	5	70	1	2C00	3	3	3.9
2155	2154	CP	8	8.95	9.33	221.1	Sewer Drainage Basin #2	No		2	2	5	1	1	1.90	1941	79	-4	6	2200	2	2	3.8
3468	3451	CP	10	10.8	5.58	209.4	Sewer Drainage Basin #3	No		3	3	3	1	1	1.90	1969	51	24	4	2300	2	2	3.8
2266	2229	CP	10	12.25	11	29.5	Sewer Drainage Basin #2	No		3	3	3	1	1	1.90	1941	79	-4	6	2500	2	2	3.8
2184	2149	CP	8	8.5	8.7	411.1	Sewer Drainage Basin #2	No	Root-X	2	2	5	1	1	1.90	1941	79	-4	6	1.00E+00	2.00E+00	2	3.8
2158	2300	CP	8	7.58	7.83	207.5	Sewer Drainage Basin #2	No		2	2	5	1	1	1.90	1941	79	-4	6	2500	2	2	3.8
3362	3361	CP	8	8.08	8	72.8	Sewer Drainage Basin #3	No		2	2	5	1	1	1.90	1969	51	24	4	2100	2	2	3.8
2238	2219	PE	8	9	13	215.8	Sewer Drainage Basin #2	No		2	3	4	1	2	1.90	2015	5	70	1	2100	2	2	3.8
3459	3458	CP	8	14.67	21.83	272.4	Sewer Drainage Basin #3	No		2	5	3	1	1	1.90	1969	51	24	4	2400	2	2	3.8
2097	2096	CP	8	5.25	8.5	102.0	Sewer Drainage Basin #2	Yes		2	2	1	6	1	3.80	1941	79	-4	6	0	1	1	3.8
2909	2096	CP	8	5.58	8.5	32.3	Sewer Drainage Basin #2	Yes		2	2	1	6	1	3.80	1941	79	-4	6	0	1	1	3.8
4070	4069	CP	8	8.25	8.6	48.0	Sewer Drainage Basin #4	Yes		2	2	1	6	1	3.80	1974	46	29	4	0	1	1	3.8
3192	3191	CP	8	11	11.75	376.4	Sewer Drainage Basin #3	No		2	3	4	1	1	1.85	1969	51	24	4	2300	2	2	3.7
3185	3184	CP	8	12	13.58	333.1	Sewer Drainage Basin #3	No		2	3	4	1	1	1.85	1976	44	31	4	2400	2	2	3.7
3188	3912	CP	8	13.83	11.33	313.6	Sewer Drainage Basin #3	No		2	3	4	1	1	1.85	1969	51	24	4	2400	2	2	3.7
3913	3188	CP	8	7.67	13.6	329.1	Sewer Drainage Basin #3	No		2	3	4	1	1	1.85	1969	51	24	4	2100	2	2	3.7
2072	2071	CP	8	8.08	12.5	301.6	Sewer Drainage Basin #2	No		2	3	4	1	1	1.85	1941	79	-4	6	2400	2	2	3.7
3123	3122	CP	8	10.08	7.25	248.8	Sewer Drainage Basin #3	No		2	3	4	1	1	1.85	1969	51	24	4	2311	2	2	3.7
3245	3244	CP	8	12.42	8.9	389.7	Sewer Drainage Basin #3	No		2	3	4	1	1	1.85	1969	51	24	4	2400	2	2	3.7
1153	1154	PVC	8	5.5	4.9	41.4	Sewer Drainage Basin #1	No		3	1	4	1	1	1.85	1963	57	18	5	2100	2	2	3.7
2098	2097	CP	8	0	5.25	205.4	Sewer Drainage Basin #2	Yes		2	1	1	6	1	3.70	1941	79	-4	6	0	1	1	3.7
3101	3080	CP	8	6.25	6.08	311.8	Sewer Drainage Basin #3	No		2	2	4	1	3	1.85	1969	51	24	4	2311	2	2	3.7
4080	4079	PVC	8	6.9	7.6	303.5	Sewer Drainage Basin #4	No		2	2	3	1	6	1.85	1974	46	29	4	2211	2	2	3.7
4081	4526	CP	8	7.7	7.3	194.1	Sewer Drainage Basin #4	No		2	2	3	1	6	1.85	1974	46	29	4	2312	2	2	3.7
4526	4080	CP	8	7.3	6.95	112.1	Sewer Drainage Basin #4	No		2	2	3	1	6	1.85	1974	46	29	4	2100	2	2	3.7
2042	2918	PE	8	8.75	8.62	230.0	Sewer Drainage Basin #2	No		3	2	3	1	2	1.85	2013	7	68	1	2200	2	2	3.7
2182	2146	PE	8	0	0	303.0	Sewer Drainage Basin #2	No		2	1	5	1	1	1.80	2018	2	73	1	1C00	2	2	3.6
PRCL082	VLT6022	XXX	0	0	0	11.0	Sewer Drainage Basin #6	No		2	1	1	1	1	1.20	1988	32	43	3		0	3	3.6
VLT6022	PRCL080	PVC	8	10.9	0	10.7	Sewer Drainage Basin #6	No		1	3	1	1	1	1.20	1988	32	43	3		0	3	3.6
6001-CO	CB6023	DIP	4	0	0	70.0	Sewer Drainage Basin #6	No		2	1	1	1	1	1.20	1988	32	43	3		0	3	3.6
6000-CO	N6000-CO	DIP	4	0	0	28.6	Sewer Drainage Basin #6	No		2	1	1	1	1	1.20	1988	32	43	3		0	3	3.6
3127	3048	CP	8	14.33	14.42	119.7	Sewer Drainage Basin #3	No		2	4	3	1	1	1.80	1969	51	24	4	2100	2	2	3.6
2207	2206	CP	8	11.83	14.42	229.5	Sewer Drainage Basin #2	No		2	4	3	1	1	1.80	1941	79	-4	6	2100	2	2	3.6
2206	2306	CP	8	14.42	10.33	182.9	Sewer Drainage Basin #2	No		2	4	3	1	1	1.80	1941	79	-4	6	2311	2	2	3.6
2210	2206	CP	8	9.58	14.42	137.7	Sewer Drainage Basin #2	No		2	4	3	1	1	1.80	1941	79	-4	6	2300	2	2	3.6
3278	3156	CP	8	11.9	14.25	292.2	Sewer Drainage Basin #3	No		2	4	3	1	1	1.80	1969	51	24	4	2100	2	2	3.6
3463	3462	CP	8	15.92	10.67	140.9	Sewer Drainage Basin #3	No		2	4	3	1	1	1.80	1969	51	24	4	2111	2	2	3.6
2324	2253	PE	8	7.58	9.08	75.6	Sewer Drainage Basin #2	No		2	2	4	1	1	1.75	2015	5	70	1	2100	2	2	3.5
1178	1177	CP	8	4.25	3.67	136.2	Sewer Drainage Basin #1	No		2	1	3	1	6	1.75	1963	57	18	5	2200	2	2	3.5
4044	4043	CP	8	10	10.85	128.3	Sewer Drainage Basin #4	No		2	3	3	1	2	1.75	1974	46	29	4	2100	2	2	3.5
2034	2033	PE	8	8.43	8	138.2	Sewer Drainage Basin #2	No		2	2	4	1	1	1.75	2013	7	68	1	2200	2	2	3.5
2325	2224	VCP	8	9.08	9.33	30.1	Sewer Drainage Basin #2	No		2	2	4	1	1	1.75	1941	79	-4	6	2400	2	2	3.5
2045	2044	CP	8	6.83	6.33	196.5	Sewer Drainage Basin #2	No		2	2	4	1	1	1.75	1941	79	-4	6	1F00	2	2	3.5
2246	2251	CP	10	6.33	6.33	148.0	Sewer Drainage Basin #2	No		2	2	4	1	1	1.75	1941	79	-4	6	2400	2	2	3.5
4012	4011	CP	8	7	9.3	73.3	Sewer Drainage Basin #4	No		2	2	3	1	4	1.75	1974	46	29	4	2300	2	2	3.5
3244	3243	CP	8	10.25	12.75	341.5	Sewer Drainage Basin #3	No		2	3	3	1	1	1.70	1969	51	24	4	2300	2	2	3.4
3452	3468	CP	8	10.17	10.8	50.0	Sewer Drainage Basin #3	No		2	3	3	1	1	1.70	1969	51	24	4	2300	2	2	3.4
3471	3470	CP	8	10.92	11.83	456.8	Sewer Drainage Basin #3	No		2	3	3	1	1	1.70	1969	51	24	4	2200	2	2	3.4
3493	3411	CP	8	11.58	11	63.7	Sewer Drainage Basin #3	No		2	3	3	1	1	1.70	1969	51	24	4	2400	2	2	3.4
2169	2168	PE	8	12.16	9.91	192.5	Sewer Drainage Basin #2	No		2	3	3	1	1	1.70	2013	7	68	1	2200	2	2	3.4
2101	2100	CP	8	9.5	10	248.2	Sewer Drainage Basin #2	No		2	3	3	1	1	1.70	1941	79	-4	6	2200	2	2	3.4
2305	2304	PVC	8	6.67	12	78.1	Sewer Drainage Basin #2	No		2	3	3	1	1	1.70	1941	79	-4	6	2200	2	2	3.4
2208	2207	CP	8	9.91	11	86.7	Sewer Drainage Basin #2	No		2	3	3	1	1	1.70	1941	79	-4	6	2300	2	2	3.4
3279	3278	CP	8	11.3	11.9	101.7	Sewer Drainage Basin #3	No		2	3	3	1	1	1.70	1969	51	24	4	2400	2	2	3.4
3263	3909	CP	8	10.25	7	304.8	Sewer Drainage Basin #3	No		2	3	3	1	1	1.70	1969	51	24	4	2111	2	2	3.4
3199	3198	CP	8	10.58	8.6	252.4	Sewer Drainage Basin #3	No		2	3	3	1	1	1.70	1969	51	24	4	2400	2	2	3.4
3436	3415	CP	8	10.17	5	123.6	Sewer Drainage Basin #3	No		2	3	3	1	1	1.70	1969	51	24	4	2100	2	2	3.4
4105	4104	CP	8	12.3	10	176.3	Sewer Drainage Basin #4	No		2	3	3	1	1	1.70	1974	46	29	4	2100	2	2	3.4
4039	4038	CP	8	11	9.5	138.7	Sewer Drainage Basin #4	No		2	3	3	1	1	1.70	1974	46	29	4	2300	2	2	3.4
3072	3027	CP	8	11.4	11.83	133.7	Sewer Drainage Basin #3	No		2	3	3	1	1	1.70	1969	51	24	4	2100	2	2	3.4
3121	3120	CP	8	9.17	10.42	452.3	Sewer Drainage Basin #3	No		2	3	3	1	1	1.70	1969	51	24	4	2500	2	2	3.4
2245	2244	CP	8	9.5	11.08	169.2	Sewer Drainage Basin #2	No		2	3	3	1	1	1.70	1941	79	-4	6	2300	2	2	3.4
4091	4090	CP	8	9	10.2	270.7	Sewer Drainage Basin #4	No		2	3	3	1	1	1.70	1974	46	29	4	2200	2	2	3.4
3335	3315	CP	8	8.33	12.33	199.6	Sewer Drainage Basin #3	No		2	3	3											

UNITID	UNITID2	MATERIAL	DIAMETER	UP DEPTH	DOWN DEPTH	PIPE LENGTH	Drainage Basin	Backbone Pipe	Quarterly Maintenance	Pipe Diameter COF	Pipe Depth COF	Road Type COF	Seismic Backbone COF	Impact on Water Bodies COF	Weighted COF	Estimated Install Year	Estimated Pipe Age	Estimated Remaining Useful Life	LOF Based on Remaining Useful Life	PACP Quick Score (Overall)	PACP Based LOF (Rounded)	Final LOF	Risk
3419-CO	3418	CP	8	0	7	168.4	Sewer Drainage Basin #3	No		2	2	3	1	1	1.60	1969	51	24	4	2400	2	2	3.2
3437-CO	3418	CP	8	0	7	165.3	Sewer Drainage Basin #3	No		2	2	3	1	1	1.60	1969	51	24	4	2100	2	2	3.2
3387	3373	CP	8	8.2	8.25	234.5	Sewer Drainage Basin #3	No		2	2	3	1	1	1.60	1969	51	24	4	2200	2	2	3.2
3424	3423	CP	8	7.67	6.92	102.0	Sewer Drainage Basin #3	No		2	2	3	1	1	1.60	1969	51	24	4	2200	2	2	3.2
2250	2326	PE	8	8.5	9	446.8	Sewer Drainage Basin #2	No		2	2	3	1	1	1.60	2015	5	70	1	2200	2	2	3.2
2170	2168	CP	8	9.33	9.75	45.0	Sewer Drainage Basin #2	No		2	2	3	1	1	1.60	2013	7	68	1	2500	2	2	3.2
5076	5075	CP	8	7.3	8	231.8	Sewer Drainage Basin #5	No		2	2	3	1	1	1.60	1973	47	28	4	1600	2	2	3.2
2194	2193	CP	8	8.67	9.75	467.3	Sewer Drainage Basin #2	No		2	2	3	1	1	1.60	1941	79	-4	6	2311	2	2	3.2
2233	2232	CP	8	8.2	5	178.4	Sewer Drainage Basin #2	No		2	2	3	1	1	1.60	1941	79	-4	6	2100	2	2	3.2
2235	2234	CP	8	8.67	6.35	266.7	Sewer Drainage Basin #2	No		2	2	3	1	1	1.60	1941	79	-4	6	2100	2	2	3.2
3102	3101	CP	8	8.92	6.25	181.0	Sewer Drainage Basin #3	No		2	2	3	1	1	1.60	1969	51	24	4	2400	2	2	3.2
3282	3281	CP	8	8	9.75	181.9	Sewer Drainage Basin #3	No		2	2	3	1	1	1.60	1969	51	24	4	2400	2	2	3.2
3283-CO	3282	CP	8	0	8	92.4	Sewer Drainage Basin #3	No		2	2	3	1	1	1.60	1969	51	24	4	2500	2	2	3.2
3259	3909	CP	8	6.5	7	44.4	Sewer Drainage Basin #3	No		2	2	3	1	1	1.60	1969	51	24	4	2100	2	2	3.2
4108	4097	CP	8	8.5	8.5	290.2	Sewer Drainage Basin #4	No		2	2	3	1	1	1.60	1974	46	29	4	2200	2	2	3.2
2053	2052	CP	8	7.33	8.83	202.2	Sewer Drainage Basin #2	No		2	2	3	1	1	1.60	1941	79	-4	6	1700	2	2	3.2
2054	2053	CP	8	7	7.33	174.0	Sewer Drainage Basin #2	No		2	2	3	1	1	1.60	1941	79	-4	6	1700	2	2	3.2
3099	3098	CP	8	8.08	8	85.3	Sewer Drainage Basin #3	No		2	2	3	1	1	1.60	1969	51	24	4	2300	2	2	3.2
2270	2233	CP	8	8.4	8.2	207.5	Sewer Drainage Basin #2	No		2	2	3	1	1	1.60	1941	79	-4	6	2100	2	2	3.2
4106	4910	CP	8	4.5	9.7	237.6	Sewer Drainage Basin #4	No		2	2	3	1	1	1.60	1974	46	29	4	2200	2	2	3.2
3277	3276	CP	8	5	9.58	146.0	Sewer Drainage Basin #3	No		2	2	3	1	1	1.60	1969	51	24	4	2300	2	2	3.2
3228	3227	CP	8	6.25	8.33	159.8	Sewer Drainage Basin #3	No		2	2	3	1	1	1.60	1969	51	24	4	2411	2	2	3.2
3522-CO	3095	CP	8	0	8.42	106.1	Sewer Drainage Basin #3	No		2	2	3	1	1	1.60	1969	51	24	4	2400	2	2	3.2
3294	3293	CP	8	8.5	8.83	97.1	Sewer Drainage Basin #3	No		2	2	3	1	1	1.60	1969	51	24	4	2500	2	2	3.2
3270	3269	CP	8	8.7	8	149.8	Sewer Drainage Basin #3	No		2	2	3	1	1	1.60	1969	51	24	4	2500	2	2	3.2
3262	3261	CP	8	5.58	7	155.1	Sewer Drainage Basin #3	No		2	2	3	1	1	1.60	1969	51	24	4	2100	2	2	3.2
2203	2202	CP	8	10.67	8.5	333.9	Sewer Drainage Basin #2	No		2	3	2	1	1	1.55	1941	79	-4	6	2411	2	2	3.1
3417	3416	CP	8	5.83	5	346.5	Sewer Drainage Basin #3	No		2	1	3	1	1	1.50	1969	51	24	4	2300	2	2	3.0
4067	4918	CP	8	14.5	8	167.3	Sewer Drainage Basin #4	No		2	4	1	1	1	1.50	1974	46	29	4	2500	2	2	3.0
2050	2049	PVC	10	8.83	8.25	174.4	Sewer Drainage Basin #2	No		3	2	1	1	1	1.50	1941	79	-4	6	2500	2	2	3.0
6010	6012	PVC	6	3	3.5	10.8	Sewer Drainage Basin #6	No		1	1	1	1	1	1.00	1988	32	43	3		0	3	3.0
VLT6020	6010	PVC	6	2.5	3	30.7	Sewer Drainage Basin #6	No		1	1	1	1	1	1.00	1988	32	43	3		0	3	3.0
PRCL080	VLT6020	XXX	0	0	0	11.4	Sewer Drainage Basin #6	No		1	1	1	1	1	1.00	1988	32	43	3		0	3	3.0
N6001B	N6001-CO	DIP	4	0	0	26.4	Sewer Drainage Basin #6	No		1	1	1	1	1	1.00	1988	32	43	3		0	3	3.0
4008	4007	CP	8	7.5	10	36.8	Sewer Drainage Basin #4	No		2	3	1	1	1	1.40	1974	46	29	4	2300	2	2	2.8
4918	4066	CP	8	8	10.2	194.4	Sewer Drainage Basin #4	No		2	3	1	1	1	1.40	1974	46	29	4	2200	2	2	2.8
3921-CO	3335	CP	6	0	8.5	66.7	Sewer Drainage Basin #3	No		1	2	3	1	1	1.40	1969	51	24	4	2100	2	2	2.8
4017	4099	CP	8	7	7.33	101.6	Sewer Drainage Basin #4	No		1	2	3	1	1	1.40	1974	46	29	4	2211	2	2	2.8
1992	1991	PVC	18	22.28	21.43	29.9		No		6	5	1	1	6	2.65	2018	2	73	1		0	1	2.7
2313-CO	2914	CP	6	0	5.42	360.2	Sewer Drainage Basin #2	No		1	1	3	1	1	1.30	1941	79	-4	6	2211	2	2	2.6
2135	2379	PVC	8	9.5	9.3	19.2	Sewer Drainage Basin #2	No		6	2	3	1	1	2.40	2009	11	64	1	0	1	1	2.4
3036	3077	CP	10	16.9	13.5	127.4	Sewer Drainage Basin #3	No		3	4	4	1	6	2.40	1969	51	24	4	0	1	1	2.4
2142	2065	PE	12	10.41	10	265.1	Sewer Drainage Basin #2	No		3	3	5	1	4	2.35	2018	2	73	1	0	1	1	2.4
3059	3015	CP	12	10.4	21.25	270.1	Sewer Drainage Basin #3	No		3	5	3	1	6	2.35	1969	51	24	4	0	1	1	2.4
4034	4033	CP	8	16.5	8	398.2	Sewer Drainage Basin #4	No		2	4	5	1	6	2.35	1974	46	29	4	0	1	1	2.4
3037	3036	CP	10	10.2	16.9	86.7	Sewer Drainage Basin #3	No		3	4	4	1	5	2.35	1969	51	24	4	0	1	1	2.4
2040	2011	CP	8	7.75	13.93	288.0	Sewer Drainage Basin #2	No		2	3	5	1	5	2.20	1941	79	-4	6	0	1	1	2.2
2038	2009	PE	8	10.39	8.9	249.6	Sewer Drainage Basin #2	No		2	3	5	1	5	2.20	2013	7	68	1	0	1	1	2.2
6033	6035	PVC	8	14.6	11.2	402.1	Sewer Drainage Basin #6	No		2	4	4	1	6	2.20	2010	10	65	1		0	1	2.2
6028	6027	PVC	8	8	12.8	455.7	Sewer Drainage Basin #6	No		2	3	5	1	5	2.20	2010	10	65	1		0	1	2.2
6024	6025	PVC	8	12.5	8.8	219.4	Sewer Drainage Basin #6	No		3	3	5	1	1	2.20	2010	10	65	1		0	1	2.2
2049	2047	CP	8	8.25	10.33	145.4	Sewer Drainage Basin #2	No		2	3	6	1	1	2.15	1941	79	-4	6	0	1	1	2.2
3067	3066	CP	8	9.25	10.83	212.4	Sewer Drainage Basin #3	No		2	3	6	1	1	2.15	1969	51	24	4	0	1	1	2.2
4033	4032	CP	8	8	4.2	42.0	Sewer Drainage Basin #4	No		2	2	5	1	6	2.15	1974	46	29	4	0	1	1	2.2
3912	3187	CP	8	111.33	12	166.6	Sewer Drainage Basin #3	No		2	6	4	1	1	2.15	1969	51	24	4	0	1	1	2.2
1421	1420	PE	12	10.45	9	145.4	Sewer Drainage Basin #1B	No		3	3	3	1	6	2.15	2011	9	66	1		0	1	2.2
2065	2141	PE	12	10	6.33	184.9	Sewer Drainage Basin #2	No		2	3	5	1	4	2.15	2018	2	73	1	0	1	1	2.2
6034	6033	PVC	8	12.2	14.6	145.0	Sewer Drainage Basin #6	No		2	4	4	1	5	2.15	2010	10	65	1		0	1	2.2
6032	6031	PVC	8	10.2	14	379.7	Sewer Drainage Basin #6	No		2	4	4	1	5	2.15	2010	10	65	1		0	1	2.2
3332	3904	CP	8	11.17	14.17	232.8	Sewer Drainage Basin #3	No		2	4	5	1	1	2.10	1969	51	24	4	0	1	1	2.1
3904	3314	CP	8	14.17	9.2	251.7	Sewer Drainage Basin #3	No		2	4	5	1	1	2.10	1969	51	24	4	0	1	1	2.1
3357	3356	CP	10	6	7.5	148.7	Sewer Drainage Basin #3	No		3	2	5	1	1	2.10	1968	52	23	5	0	1	1	2.1
3451	3361	CP	10	5.67	8	263.4	Sewer Drainage Basin #3	No		3	2	5	1	1	2.10	1969	51	24	4	0	1	1	2.1
4038	4034	CP	8	9.5	16.5	482.4	Sewer Drainage Basin #4	No		2	4	5	1	1	2.10	1974	46	29	4	0	1	1	2.1
4035	4034	CP	8	8.6	16.5	366.5	Sewer Drainage Basin #4	No		2	4	5	1	1	2.10	1974	46	29	4	0	1	1	2.1
2378	2376	PVC	10	12.25	14.75	273.4	Sewer Drainage Basin #2	No		2	4	5	1	1	2.10	1941	79	-4	6	0	1	1	2.1
2377	2376	PVC	8	12.5	14.75	131.5	Sewer Drainage Basin #2	No		2	4	5	1	1	2.10	2010	10	65	1	0	1	1	2.1
1701	1702	PVC	8	17	16.4	478.3	Sewer Drainage Basin #1B	No		2	4	5	1	1	2.10	2010	10	65	1		0	1	2.1
6037	6038	PVC	8	11.8	8.8	25																	



UNITID	UNITID2	MATERIAL	DIAMETER	UP DEPTH	DOWN DEPTH	PIPE LENGTH	Drainage Basin	Backbone Pipe	Quarterly Maintenance	Pipe Diameter COF	Pipe Depth COF	Road Type COF	Seismic Backbone COF	Impact on Water Bodies COF	Weighted COF	Estimated Install Year	Estimated Pipe Age	Estimated Remaining Useful Life	LOF Based on Remaining Useful Life	PACP Quick Score (Overall)	PACP Based LOF (Rounded)	Final LOF	Risk
3079	3078	CP	10	7.67	6.75	382.6	Sewer Drainage Basin #3	No		3	2	4	1	3	2.05	1969	51	24	4	0	1	1	2.1
2036	2343	PVC	8	9.8	6.97	181.4	Sewer Drainage Basin #2	No		2	2	5	1	4	2.05	2013	7	68	1	0	1	1	2.1
3194	3183	CP	8	7	11.17	153.8	Sewer Drainage Basin #3	No		2	3	4	1	5	2.05	1969	51	24	4	0	1	1	2.1
3054	3006	DIP	8	8.91	19.25	167.5	Sewer Drainage Basin #3	No		4	5	1	1	2	2.05	1969	51	24	4	0	1	1	2.1
3081	3513	CP	10	8.08	7.75	112.6	Sewer Drainage Basin #3	No		3	2	4	1	3	2.05	1969	51	24	4	0	1	1	2.1
2195	2154	CP	8	12	9.33	504.8	Sewer Drainage Basin #2	No		2	3	5	1	1	2.00	1941	79	-4	6	0	1	1	2.0
6005	6004	PVC	8	7.33	10	325.0	Sewer Drainage Basin #6	No		2	3	5	1	1	2.00	2010	10	65	1		0	1	2.0
2181	2900	PE	8	5.2	8.5	261.1	Sewer Drainage Basin #2	No		2	2	4	1	6	2.00	2015	5	70	1	0	1	1	2.0
3333	3332	CP	8	11.17	11.17	158.9	Sewer Drainage Basin #3	No		2	3	5	1	1	2.00	1969	51	24	4	0	1	1	2.0
3331	3330	CP	8	10.83	10.83	251.5	Sewer Drainage Basin #3	No		2	3	5	1	1	2.00	1969	51	24	4	0	1	1	2.0
3083	3082	CP	10	6.83	7.5	21.0	Sewer Drainage Basin #3	No		3	2	4	1	2	2.00	1969	51	24	4	0	1	1	2.0
3084	3083	CP	10	6.33	6.33	212.1	Sewer Drainage Basin #3	No		3	2	4	1	2	2.00	1969	51	24	4	0	1	1	2.0
2021	2908	CP	8	10.4	9.33	392.1	Sewer Drainage Basin #2	No		2	3	5	1	1	2.00	1941	79	-4	6	0	1	1	2.0
2022	2021	CP	8	10.42	10.4	465.6	Sewer Drainage Basin #2	No		2	3	5	1	1	2.00	1941	79	-4	6	0	1	1	2.0
2317	2020	CP	8	8.75	10.17	63.7	Sewer Drainage Basin #2	No		2	3	5	1	1	2.00	1941	79	-4	6	0	1	1	2.0
3034	3510	CP	12	15.5	10.58	177.0	Sewer Drainage Basin #3	No		3	4	3	1	1	2.00	1969	51	24	4	0	1	1	2.0
3364	3363	CP	8	10.75	7.83	251.2	Sewer Drainage Basin #3	No		2	3	5	1	1	2.00	1969	51	24	4	0	1	1	2.0
3366	3365	CP	8	13.17	13.25	402.0	Sewer Drainage Basin #3	No		2	3	5	1	1	2.00	1969	51	24	4	0	1	1	2.0
3367	3366	CP	8	10	13.17	369.2	Sewer Drainage Basin #3	No		2	3	5	1	1	2.00	1969	51	24	4	0	1	1	2.0
3826	3825	CP	8	10.67	13.051	413.0	Sewer Drainage Basin #3	No		2	3	5	1	1	2.00	1969	51	24	4	0	1	1	2.0
2214	2029	PVC	8	4.75	9.58	83.2	Sewer Drainage Basin #2	No		2	2	5	1	3	2.00	1941	79	-4	6	0	1	1	2.0
1726	1725	PVC	8	5	8	169.1	Sewer Drainage Basin #1B	No		2	2	4	1	6	2.00	2010	10	65	1		0	1	2.0
6031	6033	PVC	8	14	14.6	74.6	Sewer Drainage Basin #6	No		2	4	4	1	2	2.00	2010	10	65	1		0	1	2.0
6027	6030	PVC	8	12.8	13.2	50.7	Sewer Drainage Basin #6	No		2	3	5	1	1	2.00	2010	10	65	1		0	1	2.0
6001	6027	PVC	8	12.1	12.8	53.4	Sewer Drainage Basin #6	No		2	3	5	1	1	2.00	2010	10	65	1		0	1	2.0
2916	2014	PE	8	11.16	11.58	298.0	Sewer Drainage Basin #2	No		2	3	5	1	1	2.00	2013	7	68	1	0	1	1	2.0
3929-CO	3933	PVC	8	5.84	7.45	104.0		No		4	2	3	1	1	2.00	2014	6	69	1	0	1	1	2.0
4927	4926	PVC	8	8.81	14.85	241.4		No		3	4	3	1	1	2.00	2019	1	74	1		0	1	2.0
3901-CO	3085	CP	10	5.58	4.75	250.3	Sewer Drainage Basin #3	No		3	1	4	1	3	1.95	1969	51	24	4	0	1	1	2.0
2373	2372	PVC	8	12	15.9	151.4	Sewer Drainage Basin #2	No		2	4	4	1	1	1.95	1941	79	-4	6	0	1	1	2.0
1925	1924	PVC	8	0	0	290.6		No		2	1	6	1	1	1.95	2017	3	72	1	0	1	1	2.0
1926	1925	PVC	8	0	0	39.4		No		2	1	6	1	1	1.95	2017	3	72	1	0	1	1	2.0
1927	1925	PVC	8	0	0	130.2		No		2	1	6	1	1	1.95	2017	3	72	1	0	1	1	2.0
3076	3037	CP	8	9.58	9.83	12.2	Sewer Drainage Basin #3	No		2	2	4	1	5	1.95	1969	51	24	4	0	1	1	2.0
3039	3113	CP	8	0	7.6	150.0	Sewer Drainage Basin #3	No		2	2	4	1	5	1.95	1969	51	24	4	0	1	1	2.0
4413	4510	PVC	8	11	4.55	142.0	Sewer Drainage Basin #4	No		2	3	3	1	6	1.95	1974	46	29	4	0	1	1	2.0
3175	3136	CP	10	7.75	7.42	187.8	Sewer Drainage Basin #3	No		3	2	4	1	1	1.95	1969	51	24	4	0	1	1	2.0
3038	3037	CP	8	7.25	9.83	276.6	Sewer Drainage Basin #3	No		2	2	4	1	5	1.95	1969	51	24	4	0	1	1	2.0
3114	3113	PVC	8	3.3	7.6	31.5	Sewer Drainage Basin #3	No		2	2	4	1	5	1.95	1969	51	24	4	0	1	1	2.0
3113	3038	CP	8	7.6	0	152.0	Sewer Drainage Basin #3	No		2	2	4	1	5	1.95	1969	51	24	4	0	1	1	2.0
4042	CCMH048	CP	8	12.2	0	265.0	Sewer Drainage Basin #4	No		2	3	3	1	6	1.95	1974	46	29	4	0	1	1	2.0
4697	4600	PVC	8	7.33	8	51.2	Sewer Drainage Basin #4	No		3	2	3	1	4	1.95	1974	46	29	4	0	1	1	2.0
1725	1717	PVC	8	8	11.2	248.8	Sewer Drainage Basin #1B	No		2	3	4	1	3	1.95	2010	10	65	1		0	1	2.0
6038	6039	PVC	8	8.8	11.3	121.9	Sewer Drainage Basin #6	No		2	3	4	1	3	1.95	2010	10	65	1		0	1	2.0
2048	2030	PE	8	8	8.4	305.0	Sewer Drainage Basin #2	No		3	2	4	1	1	1.95	2012	8	67	1	1100	1	1	2.0
3940	3939	PVC	8	7.59	8.5	34.5		No		3	2	4	1	1	1.95	2018	2	73	1		0	1	2.0
2064	2065	PVC	8	10.5	8.25	157.0		No		1	3	5	1	4	1.95	2018	2	73	1	0	1	1	2.0
2190	2152	CP	8	8.5	9.2	292.0	Sewer Drainage Basin #2	No		2	2	5	1	1	1.90	1941	79	-4	6	0	1	1	1.9
5052	5051	CP	8	6.4	6.2	305.1	Sewer Drainage Basin #5	No		2	2	5	1	1	1.90	1973	47	28	4	0	1	1	1.9
2202	2156	CP	8	8.67	8	382.2	Sewer Drainage Basin #2	No		2	2	5	1	1	1.90	1941	79	-4	6	0	1	1	1.9
2301	2300	PVC	8	7	7.58	90.2	Sewer Drainage Basin #2	No		2	2	5	1	1	1.90	1941	79	-4	6	0	1	1	1.9
2908	2317	CP	8	9.33	8.75	322.6	Sewer Drainage Basin #2	No		2	2	5	1	1	1.90	1941	79	-4	6	0	1	1	1.9
2156	2339	CP	8	8	8.25	101.8	Sewer Drainage Basin #2	No		2	2	5	1	1	1.90	1941	79	-4	6	0	1	1	1.9
2338	2156	CP	8	7.9	7.83	10.3	Sewer Drainage Basin #2	No		2	2	5	1	1	1.90	1941	79	-4	6	0	1	1	1.9
2339	2155	CP	8	9	8.95	240.0	Sewer Drainage Basin #2	No		2	2	5	1	1	1.90	1941	79	-4	6	1100	1	1	1.9
3363	3362	CP	8	7.83	8.08	280.3	Sewer Drainage Basin #3	No		2	2	5	1	1	1.90	1969	51	24	4	0	1	1	1.9
1197	1211	CP	10	9.75	11.41	258.6	Sewer Drainage Basin #1	No		3	3	3	1	1	1.90	1963	57	18	5	0	1	1	1.9
1211	1037	CP	10	11.41	13.2	264.5	Sewer Drainage Basin #1	No		3	3	3	1	1	1.90	1963	57	18	5	0	1	1	1.9
3486	3149	CP	6	7.67	11.33	245.4	Sewer Drainage Basin #3	No		3	3	3	1	1	1.90	1969	51	24	4	0	1	1	1.9
3091	3076	CP	8	8.17	9.5	449.4	Sewer Drainage Basin #3	No		2	2	4	1	4	1.90	1969	51	24	4	0	1	1	1.9
1593	1592	PVC	8	9.83	4.33	168.0	Sewer Drainage Basin #1	No		2	2	5	1	1	1.90	1963	57	18	5	0	1	1	1.9
3057	3056	CP	8	9	8.8	98.0	Sewer Drainage Basin #3	No		2	2	5	1	1	1.90	1969	51	24	4	1100	1	1	1.9
N3476	3460	CP	8	0	10.42	111.1	Sewer Drainage Basin #3	No		3	3	3	1	1	1.90	1969	51	24	4	0	1	1	1.9
6040	6039	PVC	8	7.6	11.3	147.7	Sewer Drainage Basin #6	No		2	3	4	1	2	1.90	2010	10	65	1		0	1	1.9
6039	SV1020	PVC	8	11.3	0	42.8	Sewer Drainage Basin #6	No		2	3	4	1	2	1.90	2010	10	65	1		0	1	1.9
IG_LAUNCH	N6041PIG	XXX	0	0	0	1.8	Sewer Drainage Basin #6	No		3	1	4	1	2	1.90	2010	10	65	1		0	1	1.9
5122	5035	PVC	8	6.44	8.6	64.7		No		3	2	3	1	3	1.90	2017	3	72	1		0	1	1.9
3457	3456	CP	8	22.16	18	267.7	Sewer Drainage Basin #3	No		2	5	3	1	1	1.90	1969	51	24	4	0	1	1	1.9
3458	3457	CP	8	22.83	22.16	107.0	Sewer Drainage Basin #3	No		2	5	3	1	1	1.90	1969	51	24	4	0	1	1	1.9
3																							



UNITID	UNITID2	MATERIAL	DIAMETER	UP DEPTH	DOWN DEPTH	PIPE LENGTH	Drainage Basin	Backbone Pipe	Quarterly Maintenance	Pipe Diameter COF	Pipe Depth COF	Road Type COF	Seismic Backbone COF	Impact on Water Bodies COF	Weighted COF	Estimated Install Year	Estimated Pipe Age	Estimated Remaining Useful Life	LOF Based on Remaining Useful Life	PACP Quick Score (Overall)	PACP Based LOF (Rounded)	Final LOF	Risk	
3198	3917	CP	8	9.75	12.25	434.1	Sewer Drainage Basin #3	No		2	3	4	1	1	1.85	1976	44	31	4	0	1	1	1.9	
4045	4044	CP	8	15.7	10	107.0	Sewer Drainage Basin #4	No		2	4	3	1	2	1.85	1974	46	29	4	0	1	1	1.9	
3195	3185	CP	8	9.75	12	79.0	Sewer Drainage Basin #3	No		2	3	4	1	1	1.85	1976	44	31	4	0	1	1	1.9	
2030	2004	PVC	8	8.8	11.91	269.2	Sewer Drainage Basin #2	No		2	3	4	1	1	1.85	1941	79	-4	6	0	1	1	1.9	
2043	2920	PE	8	11.18	11.09	284.8	Sewer Drainage Basin #2	No		2	3	4	1	1	1.85	2013	7	68	1	0	1	1	1.9	
3193	3192	CP	8	11.25	11	170.3	Sewer Drainage Basin #3	No		2	3	4	1	1	1.85	1969	51	24	4	0	1	1	1.9	
3204	3191	CP	8	7	11.25	199.8	Sewer Drainage Basin #3	No		2	3	4	1	1	1.85	1969	51	24	4	0	1	1	1.9	
3246	3245	CP	8	11.42	12.67	216.6	Sewer Drainage Basin #3	No		2	3	4	1	1	1.85	1969	51	24	4	0	1	1	1.9	
3266	3247	CP	8	11.58	11	392.3	Sewer Drainage Basin #3	No		2	3	4	1	1	1.85	1969	51	24	4	0	1	1	1.9	
3190	3189	CP	8	11.25	11.17	300.2	Sewer Drainage Basin #3	No		2	3	4	1	1	1.85	1969	51	24	4	0	1	1	1.9	
3191	3190	CP	8	11.75	11.25	326.7	Sewer Drainage Basin #3	No		2	3	4	1	1	1.85	1969	51	24	4	0	1	1	1.9	
2035	2031	PE	8	10.33	7.88	396.0	Sewer Drainage Basin #2	No		2	3	4	1	1	1.85	2013	7	68	1	0	1	1	1.9	
3097	3096	CP	8	9	10	312.9	Sewer Drainage Basin #3	No		2	3	4	1	1	1.85	1969	51	24	4	1100	1	1	1	1.9
2046	2043	PE	8	10.25	11.18	183.7	Sewer Drainage Basin #2	No		2	3	4	1	1	1.85	2013	7	68	1	0	1	1	1.9	
3908-CO	3266	CP	8	0	11.58	125.7	Sewer Drainage Basin #3	No		2	3	4	1	1	1.85	1969	51	24	4	0	1	1	1.9	
4202	CCMH050	CP	8	5.25	0	20.7	Sewer Drainage Basin #4	No		4	1	1	1	6	1.85	1974	46	29	4	0	1	1	1.9	
2375	2374	PVC	8	9.75	10.6	141.5	Sewer Drainage Basin #2	No		2	3	4	1	1	1.85	2009	11	64	1	0	1	1	1.9	
1707	1708	PVC	8	10.7	10	477.8	Sewer Drainage Basin #1B	No		2	3	4	1	1	1.85	2010	10	65	1		0	1	1.9	
1708	1710	PVC	8	10	10.2	232.6	Sewer Drainage Basin #1B	No		2	3	4	1	1	1.85	2010	10	65	1		0	1	1.9	
1710	1718	PVC	8	10.2	11.8	209.3	Sewer Drainage Basin #1B	No		2	3	4	1	1	1.85	2010	10	65	1		0	1	1.9	
1718	1503	PVC	8	11.8	8.83	300.2	Sewer Drainage Basin #1B	No		2	3	4	1	1	1.85	2010	10	65	1		0	1	1.9	
1717	1718	PVC	8	11.2	11.8	35.2	Sewer Drainage Basin #1B	No		2	3	4	1	1	1.85	2010	10	65	1		0	1	1.9	
1716	1717	PVC	8	11	11.2	452.4	Sewer Drainage Basin #1B	No		2	3	4	1	1	1.85	2010	10	65	1		0	1	1.9	
1736	1519	PVC	8	12.8	10.5	336.3	Sewer Drainage Basin #1B	No		2	3	4	1	1	1.85	2010	10	65	1		0	1	1.9	
1083	1992	PVC	18	11.1	22.08	213.0		No		2	5	1	1	6	1.85	2018	2	73	1		0	1	1.9	
4203	4202	PVC	8	8.4	5.25	150.6	Sewer Drainage Basin #4	No		2	2	3	1	6	1.85	1974	46	29	4	0	1	1	1.9	
3104	3081	CP	8	7.08	8.25	178.9	Sewer Drainage Basin #3	No		2	2	4	1	3	1.85	1969	51	24	4	0	1	1	1.9	
4414-CO	4413	PVC	8	0	10.5	70.2	Sewer Drainage Basin #4	No		2	3	3	1	4	1.85	1974	46	29	4	0	1	1	1.9	
3180	3179	CP	8	6.67	8.75	368.7	Sewer Drainage Basin #3	No		2	2	3	1	6	1.85	1969	51	24	4	0	1	1	1.9	
3064	3013	CP	8	7.17	7.25	158.8	Sewer Drainage Basin #3	No		2	2	3	1	6	1.85	1969	51	24	4	0	1	1	1.9	
3507	3013	CP	8	9	7.25	57.0	Sewer Drainage Basin #3	No		2	2	3	1	6	1.85	1969	51	24	4	0	1	1	1.9	
1126	1125	PVC	8	6.25	5.17	77.3	Sewer Drainage Basin #1	No		2	2	3	1	6	1.85	1963	57	18	5	0	1	1	1.9	
4527	4526	PVC	8	5.5	7.5	69.5	Sewer Drainage Basin #4	No		2	2	3	1	6	1.85	1974	46	29	4	0	1	1	1.9	
4530	4529	PVC	8	7.5	5.5	221.9	Sewer Drainage Basin #4	No		2	2	3	1	6	1.85	1974	46	29	4	0	1	1	1.9	
4699-CO	4697	PVC	8	0	7.33	116.9	Sewer Drainage Basin #4	No		2	2	3	1	6	1.85	1974	46	29	4	0	1	1	1.9	
4075	4074	CP	8	9	9.23	31.0	Sewer Drainage Basin #4	No		2	2	3	1	6	1.85	1974	46	29	4	0	1	1	1.9	
1720	1721	PVC	8	6.5	5.9	204.1	Sewer Drainage Basin #1B	No		2	2	3	1	6	1.85	2010	10	65	1		0	1	1.9	
1134	1133	CP	8	4.15	5.42	38.5	Sewer Drainage Basin #1	No		2	1	5	1	1	1.80	1963	57	18	5	0	1	1	1.8	
1135	1134	CP	8	4	4.15	134.2	Sewer Drainage Basin #1	No		2	1	5	1	1	1.80	1963	57	18	5	0	1	1	1.8	
1592	1591	PVC	8	4.75	4	393.4	Sewer Drainage Basin #1	No		2	1	5	1	1	1.80	1963	57	18	5	0	1	1	1.8	
2180	2181	PE	8	8	5.2	255.0	Sewer Drainage Basin #2	No		2	2	3	1	5	1.80	2015	5	70	1	0	1	1	1.8	
3040	3039	CP	8	6.75	6.75	58.1	Sewer Drainage Basin #3	No		2	2	4	1	2	1.80	1969	51	24	4	0	1	1	1.8	
3074	3073	CP	8	12.42	11.08	469.8	Sewer Drainage Basin #3	No		2	3	3	1	3	1.80	1969	51	24	4	0	1	1	1.8	
3066	3022	CP	8	10.67	8.3	241.6	Sewer Drainage Basin #3	No		2	3	3	1	3	1.80	1969	51	24	4	0	1	1	1.8	
4076	4075	CP	8	9.65	9	126.0	Sewer Drainage Basin #4	No		2	2	3	1	5	1.80	1974	46	29	4	0	1	1	1.8	
4600	4601	PVC	8	11.25	9	123.8	Sewer Drainage Basin #4	No		2	3	3	1	3	1.80	1974	46	29	4	0	1	1	1.8	
2316-CO	2130	CP	8	0	8.92	23.7	Sewer Drainage Basin #2	No		3	2	3	1	1	1.80	1941	79	-4	6	0	1	1	1.8	
5084-CO	5122	PVC	8	1.71	6.24	187.4		No		2	2	3	1	5	1.80	2017	3	72	1		0	1	1.8	
1212	1211	CP	8	15	8.4	414.2	Sewer Drainage Basin #1	No	Root-X	2	4	3	1	1	1.80	1963	57	18	5	0	1	1	1.8	
5064	5063	CP	8	10.5	15	230.3	Sewer Drainage Basin #5	No		2	4	3	1	1	1.80	1973	47	28	4	0	1	1	1.8	
4010-CO	4009	CP	8	0	16.6	162.0	Sewer Drainage Basin #4	No		2	4	3	1	1	1.80	1974	46	29	4	0	1	1	1.8	
4009	4008	CP	8	16.6	7.58	209.3	Sewer Drainage Basin #4	No		2	4	3	1	1	1.80	1974	46	29	4	0	1	1	1.8	
2304	2303	PVC	8	12	16	222.6	Sewer Drainage Basin #2	No		2	4	3	1	1	1.80	1941	79	-4	6	0	1	1	1.8	
3479	3463	CP	8	6.25	14.5	106.0	Sewer Drainage Basin #3	No		2	4	3	1	1	1.80	1969	51	24	4	0	1	1	1.8	
3478	3462	CP	8	14.08	10.75	88.9	Sewer Drainage Basin #3	No		2	4	3	1	1	1.80	1969	51	24	4	0	1	1	1.8	
3273	3151	CP	8	7.5	15.33	309.0	Sewer Drainage Basin #3	No		2	4	3	1	1	1.80	1969	51	24	4	0	1	1	1.8	
3056	3529	CP	8	8.8	14	107.0	Sewer Drainage Basin #3	No		2	4	3	1	1	1.80	1969	51	24	4	0	1	1	1.8	
2925	2038	PE	8	14.1	10.39	134.0	Sewer Drainage Basin #2	No		2	4	3	1	1	1.80	2018	2	73	1		0	1	1.8	
1702	1703	PVC	8	16.4	9.5	481.8	Sewer Drainage Basin #1B	No		2	4	3	1	1	1.80	2010	10	65	1		0	1	1.8	
1703	1704	PVC	8	9.5	16	492.7	Sewer Drainage Basin #1B	No		2	4	3	1	1	1.80	2010	10	65	1		0	1	1.8	
1705	1704	PVC	8	7.5	16	221.9	Sewer Drainage Basin #1B	No		2	4	3	1	1	1.80	2010	10	65	1		0	1	1.8	
1704	1706	PVC	8	16	12.8	469.3	Sewer Drainage Basin #1B	No		2	4	3	1	1	1.80	2010	10	65	1		0	1	1.8	
2093	2082	CP	8	5.67	9.25	336.5	Sewer Drainage Basin #2	No		2	2	4	1	1	1.75	1941	79	-4	6	0	1	1	1.8	
4011	4022	CP	8	9.3	10.7	48.8	Sewer Drainage Basin #4	No		2	3	3	1	2	1.75	1974	46	29	4	0	1	1	1.8	
3119	3042	CP	8	8.67	8.92	268.7	Sewer Drainage Basin #3	No		2	2	4	1	1	1.75	1969	51	24	4	0	1	1	1.8	
3168	3133	CP	8	6.8	9.4	113.5	Sewer Drainage Basin #3	No		2	2	4	1	1	1.75	1969	51	24	4	0	1	1	1.8	
3117	3116	CP	8	9.08	9.33	300.7	Sewer Drainage Basin #3	No		2	2	4	1	1	1.75	1969	51	24	4	1100	1	1	1	1.8
3498	3919	CP	8	7.83	4.25	214.2	Sewer Drainage Basin #3	No		2	2	4	1	1	1.75	1969	51	24	4	0	1	1	1.8	
3178	3177	CP	8	11	7.58	213.6	Sewer Drainage Basin #3	No		2	3													

UNITID	UNITID2	MATERIAL	DIAMETER	UP DEPTH	DOWN DEPTH	PIPE LENGTH	Drainage Basin	Backbone Pipe	Quarterly Maintenance	Pipe Diameter COF	Pipe Depth COF	Road Type COF	Seismic Backbone COF	Impact on Water Bodies COF	Weighted COF	Estimated Install Year	Estimated Pipe Age	Estimated Remaining Useful Life	LOF Based on Remaining Useful Life	PACP Quick Score (Overall)	PACP Based LOF (Rounded)	Final LOF	Risk
4528	4527	PVC	8	5.67	5.5	68.7	Sewer Drainage Basin #4	No		2	1	3	1	6	1.75	1974	46	29	4	0	1	1	1.8
4529	4528	PVC	8	5.5	5.67	71.4	Sewer Drainage Basin #4	No		2	1	3	1	6	1.75	1974	46	29	4	0	1	1	1.8
3096	3079	CP	8	9	7.67	206.1	Sewer Drainage Basin #3	No		2	2	4	1	1	1.75	1969	51	24	4	0	1	1	1.8
2253	2224	PE	8	9	9.33	66.9	Sewer Drainage Basin #2	No		2	2	4	1	1	1.75	2015	5	70	1	0	1	1	1.8
3269	3144	CP	8	8.6	8.5	170.8	Sewer Drainage Basin #3	No		2	2	4	1	1	1.75	1969	51	24	4	0	1	1	1.8
3527	3526	PVC	8	13.5	14	139.0	Sewer Drainage Basin #3	No		2	4	1	1	6	1.75	1969	51	24	4	0	1	1	1.8
1709	1708	PVC	8	9.3	9.5	100.8	Sewer Drainage Basin #1B	No		2	2	4	1	1	1.75	2010	10	65	1		0	1	1.8
1722	1723	PVC	8	0	0	138.0	Sewer Drainage Basin #1B	No		2	1	3	1	6	1.75	2010	10	65	1		0	1	1.8
1723	1725	PVC	8	0	0	512.7	Sewer Drainage Basin #1B	No		2	1	4	1	3	1.75	2010	10	65	1		0	1	1.8
2345-CO	2029	PVC	8	9.91	9.91	109.9	Sewer Drainage Basin #2	No		1	2	5	1	2	1.75	2013	7	68	1	0	1	1	1.8
3939	3900	CP	10	8.66	7.6	373.2	Sewer Drainage Basin #3	No		2	2	4	1	1	1.75	1969	51	24	4	0	1	1	1.8
3943	3944	PVC	8	8.63	8.17	63.3		No		2	2	4	1	1	1.75	2018	2	73	1		0	1	1.8
3944	3079	CP	10	0	8.75	516.4	Sewer Drainage Basin #3	No		2	2	4	1	1	1.75	1969	51	24	4	0	1	1	1.8
4930	CCMH083	PVC	8	11.46	7.6	412.9		No		2	3	3	1	2	1.75	2019	1	74	1		0	1	1.8
4935	CCMH055	CP	8	1	0	24.0		No		2	1	3	1	6	1.75	#N/A	#N/A	#N/A	#N/A	0	1	1	1.8
4412	4413	PVC	8	9.5	6	194.0	Sewer Drainage Basin #4	No		2	2	3	1	4	1.75	1974	46	29	4	0	1	1	1.8
1713	1714	PVC	8	7.5	9.6	384.9	Sewer Drainage Basin #1B	No		2	2	3	1	4	1.75	2010	10	65	1		0	1	1.8
3528	3527	CP	8	14.9	13.5	349.0	Sewer Drainage Basin #3	No		2	4	1	1	5	1.70	1969	51	24	4	0	1	1	1.7
1719	1720	PVC	8	0	0	157.8	Sewer Drainage Basin #1B	No		2	1	3	1	5	1.70	2010	10	65	1		0	1	1.7
SV1015	6041	PVC	4	0	0	269.8	Sewer Drainage Basin #6	No		2	1	4	1	2	1.70	2010	10	65	1		0	1	1.7
SV1017	SV1018	XXX	4	0	0	2.9	Sewer Drainage Basin #1	No		2	1	4	1	2	1.70	2011	9	66	1		0	1	1.7
4079	4078	CP	8	7.6	6.4	102.1	Sewer Drainage Basin #4	No		2	2	3	1	3	1.70	1974	46	29	4	1100	1	1	1.7
3453	3452	CP	8	9.58	10.17	126.0	Sewer Drainage Basin #3	No		2	3	3	1	1	1.70	1969	51	24	4	0	1	1	1.7
3413	3412	PVC	8	10.67	11.58	250.2	Sewer Drainage Basin #3	No		2	3	3	1	1	1.70	1969	51	24	4	0	1	1	1.7
3494	3413	CP	8	7.25	10.17	168.7	Sewer Drainage Basin #3	No		2	3	3	1	1	1.70	1969	51	24	4	0	1	1	1.7
3414	3413	CP	8	7.17	10.17	146.0	Sewer Drainage Basin #3	No		2	3	3	1	1	1.70	1969	51	24	4	1100	1	1	1.7
2271	2270	CP	8	11.2	8.4	115.5	Sewer Drainage Basin #2	No		2	3	3	1	1	1.70	1941	79	-4	6	0	1	1	1.7
2255	2254	PE	8	9.92	12.05	472.7	Sewer Drainage Basin #2	No		2	3	3	1	1	1.70	2015	5	70	1	0	1	1	1.7
2326	2249	PE	8	9	11.42	448.1	Sewer Drainage Basin #2	No		2	3	3	1	1	1.70	2015	5	70	1	0	1	1	1.7
4023	4022	CP	8	10.3	10.6	248.3	Sewer Drainage Basin #4	No		2	3	3	1	1	1.70	1974	46	29	4	0	1	1	1.7
4024	4023	CP	8	10	10.3	275.9	Sewer Drainage Basin #4	No		2	3	3	1	1	1.70	1974	46	29	4	0	1	1	1.7
4112	4041	PVC	8	10.2	7.5	275.4	Sewer Drainage Basin #4	No		2	3	3	1	1	1.70	1974	46	29	4	0	1	1	1.7
2100	2087	CP	8	10	8.58	329.2	Sewer Drainage Basin #2	No		2	3	3	1	1	1.70	1941	79	-4	6	0	1	1	1.7
2196	2195	CP	8	7.25	12	122.0	Sewer Drainage Basin #2	No		2	3	3	1	1	1.70	1941	79	-4	6	1100	1	1	1.7
3075	3070	CP	8	12.33	7.08	281.9	Sewer Drainage Basin #3	No		2	3	3	1	1	1.70	1969	51	24	4	0	1	1	1.7
2302	2301	PVC	8	11.58	7	203.5	Sewer Drainage Basin #2	No		2	3	3	1	1	1.70	1941	79	-4	6	0	1	1	1.7
2306	2205	CP	8	10.33	9.33	72.0	Sewer Drainage Basin #2	No		2	3	3	1	1	1.70	1941	79	-4	6	0	1	1	1.7
3107	3106	CP	8	12.58	13.17	208.7	Sewer Drainage Basin #3	No		2	3	3	1	1	1.70	1969	51	24	4	0	1	1	1.7
3106	3105	CP	8	13.17	6.92	449.3	Sewer Drainage Basin #3	No		2	3	3	1	1	1.70	1969	51	24	4	0	1	1	1.7
3087	3086	CP	8	7.4	11.5	353.5	Sewer Drainage Basin #3	No		2	3	3	1	1	1.70	1969	51	24	4	0	1	1	1.7
3089	3088	CP	8	10	7.8	173.6	Sewer Drainage Basin #3	No		2	3	3	1	1	1.70	1969	51	24	4	0	1	1	1.7
3249	3248	CP	8	10.08	9.58	325.3	Sewer Drainage Basin #3	No		2	3	3	1	1	1.70	1969	51	24	4	0	1	1	1.7
3264	3260	CP	8	13.25	7.92	349.3	Sewer Drainage Basin #3	No		2	3	3	1	1	1.70	1969	51	24	4	0	1	1	1.7
3265-CO	3264	CP	8	0	13.25	116.5	Sewer Drainage Basin #3	No		2	3	3	1	1	1.70	1969	51	24	4	0	1	1	1.7
3216	3215	CP	8	9.25	8.25	254.6	Sewer Drainage Basin #3	No		2	2	3	1	3	1.70	1969	51	24	4	0	1	1	1.7
3224	3223	CP	8	12.5	10.92	138.6	Sewer Drainage Basin #3	No		2	3	3	1	1	1.70	1976	44	31	4	0	1	1	1.7
3340	3339	CP	8	13.5	11.17	286.5	Sewer Drainage Basin #3	No		2	3	3	1	1	1.70	1969	51	24	4	0	1	1	1.7
3922	3340	CP	8	12.25	13.5	115.6	Sewer Drainage Basin #3	No		2	3	3	1	1	1.70	1969	51	24	4	0	1	1	1.7
3927	3922	CP	8	12.67	12.25	347.5	Sewer Drainage Basin #3	No		2	3	3	1	1	1.70	1969	51	24	4	0	1	1	1.7
3464	3463	CP	8	11.92	10.5	194.6	Sewer Drainage Basin #3	No		2	3	3	1	1	1.70	1969	51	24	4	0	1	1	1.7
3287	3286	CP	8	6.83	11.4	167.1	Sewer Drainage Basin #3	No		2	3	3	1	1	1.70	1969	51	24	4	0	1	1	1.7
3928	3927	CP	8	7.67	11.75	247.9	Sewer Drainage Basin #3	No		2	3	3	1	1	1.70	1969	51	24	4	0	1	1	1.7
3497	3478	PVC	8	9.58	12.5	201.3	Sewer Drainage Basin #3	No		2	3	3	1	1	1.70	1969	51	24	4	0	1	1	1.7
3098	3506	CP	8	8	10	132.5	Sewer Drainage Basin #3	No		2	3	3	1	1	1.70	1969	51	24	4	0	1	1	1.7
3172	3171	CP	8	5.75	6.17	270.3	Sewer Drainage Basin #3	No		2	2	3	1	3	1.70	1969	51	24	4	0	1	1	1.7
3173	3172	CP	8	6	5.75	147.8	Sewer Drainage Basin #3	No		2	2	3	1	3	1.70	1969	51	24	4	0	1	1	1.7
4047	4042	CP	8	9.3	12.2	98.8	Sewer Drainage Basin #4	No		2	3	3	1	1	1.70	1974	46	29	4	0	1	1	1.7
3206	3222	CP	8	10.42	11.17	258.0	Sewer Drainage Basin #3	No		2	3	3	1	1	1.70	1969	51	24	4	0	1	1	1.7
3225	3222	CP	8	11.67	11.17	118.0	Sewer Drainage Basin #3	No		2	3	3	1	1	1.70	1969	51	24	4	0	1	1	1.7
3268	3249	CP	8	7	10.08	373.8	Sewer Drainage Basin #3	No		2	3	3	1	1	1.70	1969	51	24	4	0	1	1	1.7
2039	2038	PE	8	8.83	10.39	268.8	Sewer Drainage Basin #2	No		2	3	3	1	1	1.70	2018	2	73	1	0	1	1	1.7
3197	3196	CP	8	11.25	7.83	304.2	Sewer Drainage Basin #3	No		2	3	3	1	1	1.70	1976	44	31	4	0	1	1	1.7
3475	3459	CP	8	8.75	12.5	244.8	Sewer Drainage Basin #3	No		2	3	3	1	1	1.70	1969	51	24	4	0	1	1	1.7
2211-CO	2207	CP	8	11.83	10.83	59.3	Sewer Drainage Basin #2	No		2	3	3	1	1	1.70	1941	79	-4	6	0	1	1	1.7
1127	1126	CP	8	4.55	6.25	227.3	Sewer Drainage Basin #1	No		2	2	3	1	3	1.70	1963	57	18	5	0	1	1	1.7
3274	3153	CP	8	7.33	11.33	109.8	Sewer Drainage Basin #3	No		2	3	3	1	1	1.70	1969	51	24	4	0	1	1	1.7
4404	4403	PVC	8	8	10.83	72.9	Sewer Drainage Basin #4	No		2	3	3	1	1	1.70	1974	46	29	4	0	1	1	1.7
3344	3340	CP	8	8.5	13.5	326.9	Sewer Drainage Basin #3	No		2	3	3	1	1	1.70	1969	51	24	4	0	1	1	1.7
3508	3075	CP	8	8.42	12.33	59.9	Sewer Drainage Basin #3	No		2	3	3	1</										

UNITID	UNITID2	MATERIAL	DIAMETER	UP DEPTH	DOWN DEPTH	PIPE LENGTH	Drainage Basin	Backbone Pipe	Quarterly Maintenance	Pipe Diameter COF	Pipe Depth COF	Road Type COF	Seismic Backbone COF	Impact on Water Bodies COF	Weighted COF	Estimated Install Year	Estimated Pipe Age	Estimated Remaining Useful Life	LOF Based on Remaining Useful Life	PACP Quick Score (Overall)	PACP Based LOF (Rounded)	Final LOF	Risk
3329	3328	CP	8	7.17	10.67	279.3	Sewer Drainage Basin #3	No		2	3	3	1	1	1.70	1969	51	24	4	0	1	1	1.7
3328	3312	CP	8	10.67	8.1	281.9	Sewer Drainage Basin #3	No		2	3	3	1	1	1.70	1969	51	24	4	0	1	1	1.7
3324	3323	CP	8	8.5	11.5	409.5	Sewer Drainage Basin #3	No		2	3	3	1	1	1.70	1969	51	24	4	0	1	1	1.7
3902	3308	CP	8	9.58	10.5	297.3	Sewer Drainage Basin #3	No		2	3	3	1	1	1.70	1969	51	24	4	0	1	1	1.7
3308	3307	CP	8	10.5	12.25	302.8	Sewer Drainage Basin #3	No		2	3	3	1	1	1.70	1969	51	24	4	0	1	1	1.7
3907-CO	3284	CP	8	9.11	11.3	203.2	Sewer Drainage Basin #3	No		2	3	3	1	1	1.70	1969	51	24	4	0	1	1	1.7
3218-CO	3216	CP	6	0	7.4	125.9	Sewer Drainage Basin #3	No		2	2	3	1	3	1.70	1969	51	24	4	0	1	1	1.7
1706	1707	PVC	8	12.8	10.7	496.0	Sewer Drainage Basin #1B	No		2	3	3	1	1	1.70	2010	10	65	1		0	1	1.7
1721	1722	PVC	8	5.9	7	147.1	Sewer Drainage Basin #1B	No		2	2	2	1	6	1.70	2010	10	65	1		0	1	1.7
1715	1716	PVC	8	9.5	10.6	295.2	Sewer Drainage Basin #1B	No		2	3	3	1	1	1.70	2010	10	65	1		0	1	1.7
1712	1711	PVC	8	7	10.2	240.2	Sewer Drainage Basin #1B	No		2	3	3	1	1	1.70	2010	10	65	1		0	1	1.7
1730	1729	PVC	8	8.8	10.3	360.5	Sewer Drainage Basin #1B	No		2	3	3	1	1	1.70	2010	10	65	1		0	1	1.7
1729	1731	PVC	8	10.3	9.4	367.7	Sewer Drainage Basin #1B	No		2	3	3	1	1	1.70	2010	10	65	1		0	1	1.7
1734-CO	1732	PVC	8	0	11.6	180.0	Sewer Drainage Basin #1B	No		2	3	3	1	1	1.70	2010	10	65	1		0	1	1.7
1732	1733	PE	8	11.6	8.5	486.2	Sewer Drainage Basin #1B	No		2	3	3	1	1	1.70	2010	10	65	1		0	1	1.7
6042	6043	PVC	8	10.5	9.3	91.0	Sewer Drainage Basin #6	No		2	3	3	1	1	1.70	2010	10	65	1		0	1	1.7
6043	6044	PVC	8	9.3	12	50.7	Sewer Drainage Basin #6	No		2	3	3	1	1	1.70	2010	10	65	1		0	1	1.7
6044	6005	PVC	8	12	7.3	80.7	Sewer Drainage Basin #6	No		2	3	3	1	1	1.70	2010	10	65	1		0	1	1.7
6022	6023	PVC	8	11.5	10.2	122.9	Sewer Drainage Basin #6	No		2	3	3	1	1	1.70	2010	10	65	1		0	1	1.7
1728	1729	PVC	8	9.6	10.3	18.5	Sewer Drainage Basin #1B	No		2	3	3	1	1	1.70	2010	10	65	1		0	1	1.7
2047	2916	PE	8	10.65	11.13	244.3	Sewer Drainage Basin #2	No		2	3	3	1	1	1.70	2013	7	68	1	0	1	1	1.7
3928-CO	3107	PVC	6	0	12.58	88.1	Sewer Drainage Basin #3	No		2	3	3	1	1	1.70	2013	7	68	1	0	1	1	1.7
3936	3937	PVC	8	9.52	10.97	58.0		No		2	3	3	1	1	1.70	#N/A	#N/A	#N/A	#N/A	0	1	1	1.7
4934	CCMH082	PVC	8	9.71	12.09	96.0		No		2	3	3	1	1	1.70	2019	1	74	1		0	1	1.7
4932	4930	PVC	8	5.63	11.58	467.6		No		2	3	3	1	1	1.70	2019	1	74	1		0	1	1.7
1080	1301	PVC	8	9.63	10.17	0.0		No		2	3	3	1	1	1.70	2019	1	74	1		0	1	1.7
3300	3299	CP	8	0	0	406.0	Sewer Drainage Basin #3	No		2	1	4	1	1	1.65	1969	51	24	4	0	1	1	1.7
2379	2378	PVC	8	9.5	12.25	132.0	Sewer Drainage Basin #2	No		1	3	4	1	1	1.65	1941	79	-4	6	0	1	1	1.7
1711	1710	PVC	8	0	0	449.9	Sewer Drainage Basin #1B	No		2	1	4	1	1	1.65	2010	10	65	1		0	1	1.7
6035	6036	PVC	8	11.2	10.5	106.0	Sewer Drainage Basin #6	No		2	3	1	1	6	1.65	2010	10	65	1		0	1	1.7
6036	6037	PVC	8	10.5	11.8	264.1	Sewer Drainage Basin #6	No		2	3	1	1	6	1.65	2010	10	65	1		0	1	1.7
3941	3940	PVC	8	0	0	138.0		No		2	1	4	1	1	1.65	2018	2	73	1		0	1	1.7
3174	3924	CP	8	6.42	6.58	182.0	Sewer Drainage Basin #3	No		2	2	3	1	2	1.65	1969	51	24	4	0	1	1	1.7
4205	4204	PVC	8	9.42	6.25	268.9	Sewer Drainage Basin #4	No		2	2	3	1	2	1.65	1974	46	29	4	0	1	1	1.7
3177	3176	CP	8	7.5	9	103.3	Sewer Drainage Basin #3	No		2	2	3	1	2	1.65	1969	51	24	4	0	1	1	1.7
3179	3178	CP	8	8.75	9.9	111.5	Sewer Drainage Basin #3	No		2	2	3	1	2	1.65	1969	51	24	4	1100	1	1	1.7
3176	3175	CP	8	9	7.5	82.8	Sewer Drainage Basin #3	No		2	2	3	1	2	1.65	1969	51	24	4	0	1	1	1.7
2239	2238	PE	8	9.3	9	190.8	Sewer Drainage Basin #2	No		2	2	3	1	2	1.65	2015	5	70	1	0	1	1	1.7
1724	1723	PVC	8	9	9.7	90.0	Sewer Drainage Basin #1B	No		2	2	3	1	2	1.65	2010	10	65	1		0	1	1.7
2121	2214	PVC	8	4.75	5	65.3	Sewer Drainage Basin #2	No		2	1	3	1	3	1.60	1941	79	-4	6	0	1	1	1.6
1746	1700	PVC	8	0	0	434.7	Sewer Drainage Basin #1B	No		1	1	5	1	1	1.60	2010	10	65	1		0	1	1.6
4926	CCMH081	PVC	8	15.06	6.41	53.5		No		1	4	3	1	1	1.60	2019	1	74	1		0	1	1.6
4050	4049	CP	8	8.9	9.5	102.7	Sewer Drainage Basin #4	No		2	2	3	1	1	1.60	1974	46	29	4	0	1	1	1.6
4051	4050	CP	8	5.4	8.9	66.0	Sewer Drainage Basin #4	No		2	2	3	1	1	1.60	1974	46	29	4	0	1	1	1.6
2277-CO	2250	PVC	8	4	8.25	106.4	Sewer Drainage Basin #2	No		2	2	3	1	1	1.60	1941	79	-4	6	0	1	1	1.6
3415	3414	CP	8	5	7.17	354.9	Sewer Drainage Basin #3	No		2	2	3	1	1	1.60	1969	51	24	4	0	1	1	1.6
3397	3396	CP	8	9.25	7.75	123.8	Sewer Drainage Basin #3	No		2	2	3	1	1	1.60	1969	51	24	4	0	1	1	1.6
3439	3395	CP	8	5.83	6.83	160.7	Sewer Drainage Basin #3	No		2	2	3	1	1	1.60	1969	51	24	4	0	1	1	1.6
3422	3421	CP	8	7.42	7.92	342.8	Sewer Drainage Basin #3	No		2	2	3	1	1	1.60	1969	51	24	4	0	1	1	1.6
3425-CO	3424	CP	8	4.5	7.67	179.4	Sewer Drainage Basin #3	No		2	2	3	1	1	1.60	1969	51	24	4	0	1	1	1.6
3356	3355	CP	8	7.5	8.8	322.5	Sewer Drainage Basin #3	No		2	2	3	1	1	1.60	1969	51	24	4	0	1	1	1.6
3448	3356	CP	8	9.25	7.5	303.9	Sewer Drainage Basin #3	No		2	2	3	1	1	1.60	1969	51	24	4	0	1	1	1.6
3427	3426	CP	8	8.75	8.83	126.8	Sewer Drainage Basin #3	No		2	2	3	1	1	1.60	1969	51	24	4	0	1	1	1.6
3435	3434	CP	8	5.7	6.8	169.4	Sewer Drainage Basin #3	No		2	2	3	1	1	1.60	1969	51	24	4	0	1	1	1.6
2256	2255	PE	8	9.83	9.92	370.7	Sewer Drainage Basin #2	No		2	2	3	1	1	1.60	2015	5	70	1	0	1	1	1.6
2327	2242	CP	8	9.08	7.75	70.1	Sewer Drainage Basin #2	No		2	2	3	1	1	1.60	1941	79	-4	6	0	1	1	1.6
3353	3352	CP	8	9	8	215.7	Sewer Drainage Basin #3	No		2	2	3	1	1	1.60	1969	51	24	4	0	1	1	1.6
3354	3353	CP	8	8.83	9	143.0	Sewer Drainage Basin #3	No		2	2	3	1	1	1.60	1969	51	24	4	0	1	1	1.6
2114	2113	CP	8	7.67	6.83	133.6	Sewer Drainage Basin #2	No		2	2	3	1	1	1.60	1941	79	-4	6	0	1	1	1.6
2276-CO	2275	CP	8	0	6.83	139.2	Sewer Drainage Basin #2	No		2	2	3	1	1	1.60	1941	79	-4	6	0	1	1	1.6
2197	2196	CP	8	7.33	7.25	152.9	Sewer Drainage Basin #2	No		2	2	3	1	1	1.60	1941	79	-4	6	0	1	1	1.6
2269	2231	CP	8	7.5	5	198.7	Sewer Drainage Basin #2	No	Flushing Lines	2	2	3	1	1	1.60	1941	79	-4	6	0	1	1	1.6
3088	3087	CP	8	7.8	7.4	246.4	Sewer Drainage Basin #3	No		2	2	3	1	1	1.60	1969	51	24	4	1100	1	1	1.6
3229	3228	CP	8	6.25	6.25	37.2	Sewer Drainage Basin #3	No		2	2	3	1	1	1.60	1969	51	24	4	0	1	1	1.6
3200	3198	CP	8	6.92	8.6	176.6	Sewer Drainage Basin #3	No		2	2	3	1	1	1.60	1969	51	24	4	0	1	1	1.6
3915	3200	PVC	8	8	6.92	178.5	Sewer Drainage Basin #3	No		2	2	3	1	1	1.60	1969	51	24	4	0	1	1	1.6
3169	3168	CP	8	5.92	6.52	227.4	Sewer Drainage Basin #3	No		2	2	3	1	1	1.60	1969	51	24	4	0	1	1	1.6
3477	3461	CP	8	6.67	7.65	254.7	Sewer Drainage Basin #3	No		2	2	3	1	1	1.60	1969	51	24	4	0	1	1	1.6
3051	3050	CP	8	7.42	5.5	270.4	Sewer Drainage Basin #3	No		2	2	3	1	1	1.60	1969	51	24	4	0	1	1	1.6
4206																							

UNITID	UNITID2	MATERIAL	DIAMETER	UP DEPTH	DOWN DEPTH	PIPE LENGTH	Drainage Basin	Backbone Pipe	Quarterly Maintenance	Pipe Diameter COF	Pipe Depth COF	Road Type COF	Seismic Backbone COF	Impact on Water Bodies COF	Weighted COF	Estimated Install Year	Estimated Pipe Age	Estimated Remaining Useful Life	LOF Based on Remaining Useful Life	PACP Quick Score (Overall)	PACP Based LOF (Rounded)	Final LOF	Risk	
3209	3208	CP	8	7.83	7.83	64.2	Sewer Drainage Basin #3	No		2	2	3	1	1	1.60	1969	51	24	4	0	1	1	1.6	
3210	3209	CP	8	7.92	7.83	65.6	Sewer Drainage Basin #3	No		2	2	3	1	1	1.60	1969	51	24	4	0	1	1	1.6	
3211	3210	CP	8	9.42	7.92	237.1	Sewer Drainage Basin #3	No		2	2	3	1	1	1.60	1969	51	24	4	0	1	1	1.6	
4109	4108	CP	8	5.5	8.5	281.2	Sewer Drainage Basin #4	No		2	2	3	1	1	1.60	1974	46	29	4	0	1	1	1.6	
4098	4097	CP	8	7.5	8.5	315.2	Sewer Drainage Basin #4	No		2	2	3	1	1	1.60	1974	46	29	4	0	1	1	1.6	
3215	3207	CP	8	8.25	7.75	229.4	Sewer Drainage Basin #3	No		2	2	3	1	1	1.60	1969	51	24	4	0	1	1	1.6	
3068	3067	CP	8	8.08	9.25	207.9	Sewer Drainage Basin #3	No		2	2	3	1	1	1.60	1969	51	24	4	0	1	1	1.6	
3069	3068	CP	8	9.83	8.08	249.0	Sewer Drainage Basin #3	No		2	2	3	1	1	1.60	1969	51	24	4	0	1	1	1.6	
4099	4098	CP	8	7.2	7.5	209.8	Sewer Drainage Basin #4	No		2	2	3	1	1	1.60	1974	46	29	4	0	1	1	1.6	
4016	4500	CP	8	9	9.33	24.7	Sewer Drainage Basin #4	No		2	2	3	1	1	1.60	1974	46	29	4	0	1	1	1.6	
4500	4017	CP	8	9.33	6.33	174.5	Sewer Drainage Basin #4	No		2	2	3	1	1	1.60	1974	46	29	4	0	1	1	1.6	
3170	3925	CP	8	6.08	8.17	101.1	Sewer Drainage Basin #3	No		2	2	3	1	1	1.60	1969	51	24	4	0	1	1	1.6	
3490-CO	3489	PVC	8	0	6.33	192.5	Sewer Drainage Basin #3	No		2	2	3	1	1	1.60	1969	51	24	4	0	1	1	1.6	
4040	4039	CP	8	8.5	9.6	149.7	Sewer Drainage Basin #4	No		2	2	3	1	1	1.60	1974	46	29	4	0	1	1	1.6	
4041	4040	CP	8	7.5	8.5	174.3	Sewer Drainage Basin #4	No		2	2	3	1	1	1.60	1974	46	29	4	0	1	1	1.6	
4046-CO	4045	CP	8	0	8.42	229.2	Sewer Drainage Basin #4	No		2	2	3	1	1	1.60	1974	46	29	4	0	1	1	1.6	
3275	3155	CP	8	5.58	8.67	160.0	Sewer Drainage Basin #3	No		2	2	3	1	1	1.60	1969	51	24	4	0	1	1	1.6	
3071	3070	CP	8	8.75	7.25	432.0	Sewer Drainage Basin #3	No		2	2	3	1	1	1.60	1969	51	24	4	0	1	1	1.6	
3267	3248	CP	8	8.42	9.58	232.1	Sewer Drainage Basin #3	No		2	2	3	1	1	1.60	1969	51	24	4	1100	1	1	1	1.6
4421	4420	CP	8	9.5	9.6	109.8	Sewer Drainage Basin #4	No		2	2	3	1	1	1.60	1974	46	29	4	0	1	1	1.6	
2274-CO	2273	CP	8	0	8.33	149.8	Sewer Drainage Basin #2	No		2	2	3	1	1	1.60	1941	79	-4	6	0	1	1	1.6	
3234	3233	CP	8	8.08	7.35	327.3	Sewer Drainage Basin #3	No		2	2	3	1	1	1.60	1969	51	24	4	0	1	1	1.6	
3196	3195	CP	8	7.83	9.75	144.8	Sewer Drainage Basin #3	No		2	2	3	1	1	1.60	1976	44	31	4	0	1	1	1.6	
2340	2205	CP	8	5.75	9.33	119.1	Sewer Drainage Basin #2	No		2	2	3	1	1	1.60	1941	79	-4	6	0	1	1	1.6	
4409	4404	PVC	8	8.4	8	88.5	Sewer Drainage Basin #4	No		2	2	3	1	1	1.60	1974	46	29	4	0	1	1	1.6	
4401	4400	PVC	8	7	5.7	152.5	Sewer Drainage Basin #4	No		2	2	3	1	1	1.60	1974	46	29	4	0	1	1	1.6	
4402	4401	PVC	8	6.5	7	157.3	Sewer Drainage Basin #4	No		2	2	3	1	1	1.60	1974	46	29	4	0	1	1	1.6	
4403	4402	PVC	8	8	6.33	303.7	Sewer Drainage Basin #4	No		2	2	3	1	1	1.60	1974	46	29	4	0	1	1	1.6	
4405	4404	PVC	8	6.33	8	76.6	Sewer Drainage Basin #4	No		2	2	3	1	1	1.60	1974	46	29	4	0	1	1	1.6	
4406	4405	PVC	8	7	6.33	283.3	Sewer Drainage Basin #4	No		2	2	3	1	1	1.60	1974	46	29	4	0	1	1	1.6	
4407	4406	PVC	8	8.5	7	256.2	Sewer Drainage Basin #4	No		2	2	3	1	1	1.60	1974	46	29	4	0	1	1	1.6	
4408-CO	4407	PVC	8	0	8.5	120.8	Sewer Drainage Basin #4	No		2	2	3	1	1	1.60	1974	46	29	4	0	1	1	1.6	
4410-CO	4409	PVC	8	0	8.25	142.2	Sewer Drainage Basin #4	No		2	2	3	1	1	1.60	1974	46	29	4	0	1	1	1.6	
3094	3093	CP	8	9.17	9.42	298.4	Sewer Drainage Basin #3	No	Root-X	2	2	3	1	1	1.60	1969	51	24	4	1200	1	1	1.6	
1204	1203	CP	8	8.83	8.33	362.1	Sewer Drainage Basin #1	No	Root-X	2	2	3	1	1	1.60	1963	57	18	5	0	1	1	1.6	
4602	4601	PVC	8	7.75	9	74.2	Sewer Drainage Basin #4	No		2	2	3	1	1	1.60	1974	46	29	4	0	1	1	1.6	
4603	4602	PVC	8	7	7.75	77.3	Sewer Drainage Basin #4	No		2	2	3	1	1	1.60	1974	46	29	4	0	1	1	1.6	
4607	4603	PVC	8	8.33	7	172.4	Sewer Drainage Basin #4	No		2	2	3	1	1	1.60	1974	46	29	4	0	1	1	1.6	
3203	3202	CP	8	7.53	8.17	173.6	Sewer Drainage Basin #3	No		2	2	3	1	1	1.60	1969	51	24	4	0	1	1	1.6	
4083	4200	CP	8	9.58	7.33	129.8	Sewer Drainage Basin #4	No		2	2	3	1	1	1.60	1974	46	29	4	0	1	1	1.6	
4201-CO	4200	PVC	8	0	7.33	120.9	Sewer Drainage Basin #4	No		2	2	3	1	1	1.60	1974	46	29	4	0	1	1	1.6	
4604	4603	PVC	8	7.17	7	207.1	Sewer Drainage Basin #4	No		2	2	3	1	1	1.60	1974	46	29	4	0	1	1	1.6	
4605	4604	PVC	8	7.33	7.17	137.2	Sewer Drainage Basin #4	No		2	2	3	1	1	1.60	1974	46	29	4	0	1	1	1.6	
4606-CO	4605	PVC	8	0	7.33	108.3	Sewer Drainage Basin #4	No		2	2	3	1	1	1.60	1974	46	29	4	0	1	1	1.6	
4608-CO	4605	PVC	8	0	7.33	150.4	Sewer Drainage Basin #4	No		2	2	3	1	1	1.60	1974	46	29	4	0	1	1	1.6	
4089	4088	CP	8	8.5	8.1	347.0	Sewer Drainage Basin #4	No		2	2	3	1	1	1.60	1974	46	29	4	0	1	1	1.6	
4092	4091	CP	8	7.9	9	250.8	Sewer Drainage Basin #4	No		2	2	3	1	1	1.60	1974	46	29	4	0	1	1	1.6	
4093	4092	CP	8	7.3	7.9	293.0	Sewer Drainage Basin #4	No		2	2	3	1	1	1.60	1974	46	29	4	0	1	1	1.6	
2175	2901	PE	8	7.16	7.83	330.8	Sewer Drainage Basin #2	No		2	2	3	1	1	1.60	2018	2	73	1	0	1	1	1.6	
2926	2175	PE	8	4.5	7.2	340.7	Sewer Drainage Basin #2	No		2	2	3	1	1	1.60	2018	2	73	1	0	1	1	1.6	
4601	4530	PVC	8	9	7.5	138.0	Sewer Drainage Basin #4	No		2	2	3	1	1	1.60	1974	46	29	4	0	1	1	1.6	
4531	4530	PVC	8	6.58	7.5	354.3	Sewer Drainage Basin #4	No		2	2	3	1	1	1.60	1974	46	29	4	0	1	1	1.6	
4532	4531	PVC	8	6.67	6.58	159.9	Sewer Drainage Basin #4	No		2	2	3	1	1	1.60	1974	46	29	4	0	1	1	1.6	
4053	4052	CP	8	8.2	5.33	126.2	Sewer Drainage Basin #4	No		2	2	3	1	1	1.60	1974	46	29	4	0	1	1	1.6	
3905-CO	3316	CP	8	0	8.2	122.7	Sewer Drainage Basin #3	No		2	2	3	1	1	1.60	1969	51	24	4	0	1	1	1.6	
3502-CO	3234	PVC	8	0	8.08	50.5	Sewer Drainage Basin #3	No		2	2	3	1	1	1.60	1969	51	24	4	0	1	1	1.6	
3326	3312	CP	8	6.25	8	249.2	Sewer Drainage Basin #3	No		2	2	3	1	1	1.60	1969	51	24	4	0	1	1	1.6	
3327	3326	CP	8	5.75	6.25	249.3	Sewer Drainage Basin #3	No		2	2	3	1	1	1.60	1969	51	24	4	0	1	1	1.6	
3293	3292	CP	8	8.83	9	134.5	Sewer Drainage Basin #3	No		2	2	3	1	1	1.60	1969	51	24	4	0	1	1	1.6	
3260	3259	CP	8	7.92	6.5	240.9	Sewer Drainage Basin #3	No		2	2	3	1	1	1.60	1969	51	24	4	0	1	1	1.6	
3491-CO	3271	PVC	8	0	7.8	196.2	Sewer Drainage Basin #3	No		2	2	3	1	1	1.60	1969	51	24	4	0	1	1	1.6	
3271	3270	CP	8	7.8	8.7	111.5	Sewer Drainage Basin #3	No		2	2	3	1	1	1.60	1969	51	24	4	0	1	1	1.6	
3272	3269	CP	8	5.4	8.6	270.0	Sewer Drainage Basin #3	No		2	2	3	1	1	1.60	1969	51	24	4	0	1	1	1.6	
3499	3260	CP	8	7.67	7.92	227.7	Sewer Drainage Basin #3	No		2	2	3	1	1	1.60	1969	51	24	4	0	1	1	1.6	
3261	3499	CP	8	7	7.67	150.8	Sewer Drainage Basin #3	No		2	2	3	1	1	1.60	1969	51	24	4	0	1	1	1.6	
3125	3124	CP	8	7	7.58	186.6	Sewer Drainage Basin #3	No		2	2	3	1	1	1.60	1969	51	24	4	0	1	1	1.6	
3051-CO	3051	CP	8	0	7.42	100.5	Sewer Drainage Basin #3	No		2	2	3	1	1	1.60	1969	51	24	4	0	1	1	1.6	
2332-CO	2260	CP	6	0	7.5	85.2	Sewer Drainage Basin #2	No		2	2	3	1	1	1.60	1941	79	-4	6	0	1	1	1.6	
2380	2379	PVC	8	8.75	9.5	47.9	Sewer Drainage Basin #2	No		2	2	3</												



UNITID	UNITID2	MATERIAL	DIAMETER	UP DEPTH	DOWN DEPTH	PIPE LENGTH	Drainage Basin	Backbone Pipe	Quarterly Maintenance	Pipe Diameter COF	Pipe Depth COF	Road Type COF	Seismic Backbone COF	Impact on Water Bodies COF	Weighted COF	Estimated Install Year	Estimated Pipe Age	Estimated Remaining Useful Life	LOF Based on Remaining Useful Life	PACP Quick Score (Overall)	PACP Based LOF (Rounded)	Final LOF	Risk
4912	4911	CP	8	9.67	9.4	77.7	Sewer Drainage Basin #4	No		2	2	1	1	6	1.55	1974	46	29	4	1100	1	1	1.6
4909	CCMH057	CP	8	6	0	109.4	Inaccessible For Maintenance	No		2	2	1	1	6	1.55	#N/A	#N/A	#N/A	#N/A	0	1	1	1.6
4911	4028	CP	8	9.4	6	47.0	Inaccessible For Maintenance	No		2	2	1	1	6	1.55	#N/A	#N/A	#N/A	#N/A	0	1	1	1.6
5-PUMP1_C	SV1016	XXX	4	0	0	19.4	Sewer Drainage Basin #1	No		1	1	4	1	3	1.55	2011	9	66	1		0	1	1.6
SV1019	CB-LS-WELL	XXX	0	0	0	15.3	Sewer Drainage Basin #1	No		1	1	4	1	3	1.55	2011	9	66	1		0	1	1.6
4415-CO	4109	CP	8	0	5.5	200.1	Sewer Drainage Basin #4	No		2	1	3	1	1	1.50	1974	46	29	4	0	1	1	1.5
3485	3484	CP	8	4.67	4.83	86.7	Sewer Drainage Basin #3	No		2	1	3	1	1	1.50	1969	51	24	4	0	1	1	1.5
2128	2127	CP	8	5.42	5.5	151.9	Sewer Drainage Basin #2	No		2	1	3	1	1	1.50	1941	79	-4	6	0	1	1	1.5
3503	3316	PVC	6	8.5	11.5	150.7	Sewer Drainage Basin #3	No	Flushing Lines	1	3	3	1	1	1.50	1969	51	24	4	0	1	1	1.5
4919	4067	CP	8	12.2	14.5	165.9	Sewer Drainage Basin #4	No		2	4	1	1	1	1.50	1974	46	29	4	1100	1	1	1.5
4400	4109	PVC	8	5.7	5.5	30.2	Sewer Drainage Basin #4	No		2	1	3	1	1	1.50	1974	46	29	4	0	1	1	1.5
1136	1135	CP	8	4	4	100.4	Sewer Drainage Basin #1	No		2	1	3	1	1	1.50	1963	57	18	5	0	1	1	1.5
1137	1136	CP	8	4.4	4	128.3	Sewer Drainage Basin #1	No		2	1	3	1	1	1.50	1963	57	18	5	0	1	1	1.5
1138	1137	CP	8	4.67	4.17	56.8	Sewer Drainage Basin #1	No		2	1	3	1	1	1.50	1963	57	18	5	0	1	1	1.5
1139	1138	CP	8	4.66	4.69	68.7	Sewer Drainage Basin #1	No		2	1	3	1	1	1.50	1963	57	18	5	0	1	1	1.5
1140-CO	1139	CP	8	0	4.66	70.4	Sewer Drainage Basin #1	No		2	1	3	1	1	1.50	1963	57	18	5	0	1	1	1.5
3833	CCMH060	CP	8	0	0	118.3	Sewer Drainage Basin #3	No		2	1	3	1	1	1.50	1969	51	24	4	0	1	1	1.5
3529	3528	PVC	8	14	15	138.5	Sewer Drainage Basin #3	No		2	4	1	1	1	1.50	1969	51	24	4	0	1	1	1.5
3472-CO	3471	CP	8	0	10.92	116.7	Sewer Drainage Basin #3	No		1	3	3	1	1	1.50	1969	51	24	4	0	1	1	1.5
2912	2913	CP	6	0	0	177.6	Sewer Drainage Basin #2	No		2	1	3	1	1	1.50	1941	79	-4	6	0	1	1	1.5
2311-CO	2912	PVC	8	0	5.5	312.2	Sewer Drainage Basin #2	No		2	1	3	1	1	1.50	1941	79	-4	6	0	1	1	1.5
1731	1732	PVC	8	0	0	166.0	Sewer Drainage Basin #1B	No		2	1	3	1	1	1.50	2010	10	65	1		0	1	1.5
1727	1728	PVC	8	0	0	484.1	Sewer Drainage Basin #1B	No		2	1	3	1	1	1.50	2010	10	65	1		0	1	1.5
6023	6024	PVC	8	10.2	12.5	199.7	Sewer Drainage Basin #6	No		1	3	3	1	1	1.50	2010	10	65	1		0	1	1.5
5-PUMP2_C	SV1017	XXX	4	0	0	15.4	Sewer Drainage Basin #1	No		1	1	4	1	2	1.50	2011	9	66	1		0	1	1.5
SV1018	N6041V	XXX	4	0	0	3.1	Sewer Drainage Basin #1	No		1	1	4	1	2	1.50	2011	9	66	1		0	1	1.5
SV1016	SV1015	XXX	4	0	0	3.0	Sewer Drainage Basin #1	No		1	1	4	1	2	1.50	2011	9	66	1		0	1	1.5
3927-CO	3197	PVC	8	0	11.25	98.4	Sewer Drainage Basin #3	No		1	3	3	1	1	1.50	1900	120	-45	6	0	1	1	1.5
3934	3936	PVC	8	11.37	9.3	172.6		No		1	3	3	1	1	1.50	#N/A	#N/A	#N/A	#N/A	0	1	1	1.5
4018-CO	4094	XXX	8	0	5.3	33.6	Sewer Drainage Basin #4	No		2	1	2	1	3	1.45	1974	46	29	4	0	1	1	1.5
4037	4511	CP	8	4	7	88.0	Sewer Drainage Basin #4	No		2	2	1	1	4	1.45	1974	46	29	4	0	1	1	1.5
4030	4029	CP	8	7.58	9.67	267.8	Sewer Drainage Basin #4	No		2	2	2	1	1	1.45	1974	46	29	4	1100	1	1	1.5
3926-CO	3171	CP	6	0	6.17	146.3	Sewer Drainage Basin #3	No		1	2	3	1	2	1.45	1969	51	24	4	0	1	1	1.5
3053	3004	DIP	8	6	10.5	157.7	Sewer Drainage Basin #3	No		2	3	1	1	1	1.40	1969	51	24	4	0	1	1	1.4
4929	4930	PVC	8	8.47	11.58	365.2		No		2	3	1	1	1	1.40	2019	1	74	1		0	1	1.4
4052	4051	CP	8	7.2	5.5	103.7	Sewer Drainage Basin #4	No		2	2	1	1	1	1.30	1974	46	29	4	0	1	1	1.3
4928	4927	PVC	8	9.31	8.58	258.5		No		2	2	1	1	1	1.30	2019	1	74	1		0	1	1.3
4933	4934	PVC	8	5.2	9.56	179.0		No		2	2	1	1	1	1.30	2019	1	74	1		0	1	1.3
3906-CO	3115	CP	0	0	0	93.4	Sewer Drainage Basin #3	No		1	1	3	1	1	1.30	1969	51	24	4	0	1	1	1.3
3920-CO	3275	CP	8	0	5.58	60.3	Sewer Drainage Basin #3	No		2	1	1	1	1	1.20	1969	51	24	4	0	1	1	1.2
6016-CO	6016	PVC	8	0	0	140.6	Sewer Drainage Basin #6	No		2	1	1	1	1	1.20	2011	9	66	1		0	1	1.2
DBC8-5	NDBC824	PVC	8	0	0	14.2	Sewer Drainage Basin #6	No		2	1	1	1	1	1.20	2011	9	66	1		0	1	1.2
DBC8-4	NDBC820	PVC	8	0	0	14.1	Sewer Drainage Basin #6	No		2	1	1	1	1	1.20	2011	9	66	1		0	1	1.2
DBC8-3	NDBC814	PVC	8	0	0	13.7	Sewer Drainage Basin #6	No		2	1	1	1	1	1.20	2011	9	66	1		0	1	1.2
DBC8-2	NDBC888	PVC	8	0	0	13.6	Sewer Drainage Basin #6	No		2	1	1	1	1	1.20	2011	9	66	1		0	1	1.2
DBC8-1	NDBC848	PVC	8	0	0	13.5	Sewer Drainage Basin #6	No		2	1	1	1	1	1.20	2011	9	66	1		0	1	1.2
6016	WQVLT-1	PVC	8	0	0	13.9	Sewer Drainage Basin #6	No		2	1	1	1	1	1.20	2011	9	66	1		0	1	1.2
WQVLT-1	6011	XXX	0	0	0	16.9	Sewer Drainage Basin #6	No		2	1	1	1	1	1.20	2011	9	66	1		0	1	1.2
4923	4932	PVC	8	4.27	5.4	61.4		No		2	1	1	1	1	1.20	2019	1	74	1		0	1	1.2
DBC8-6	NDBC818	PVC	8	0	0	14.3	Sewer Drainage Basin #6	No		1	1	1	1	1	1.00	2011	9	66	1		0	1	1.0



# Appendix H. Level of Service Technical Memorandum



**WASTEWATER SYSTEM MASTER PLAN  
ANALYSIS OF SYSTEM SEISMIC RESILIENCE**

**CITY OF MILWAUKIE PUBLIC WORKS DEPARTMENT  
MILWAUKIE, OREGON**

---

**Final Technical Memorandum: Level of Service Goals, Performance  
Objectives, and Wastewater System Backbone**

September 9<sup>th</sup>, 2020  
SEFT Project Number: B19013.00

# Table of Contents

<b>List of Figures .....</b>	<b>ii</b>
<b>List of Tables.....</b>	<b>iii</b>
<b>1.0 Introduction and Background .....</b>	<b>1</b>
1.1 City of Milwaukie Wastewater System Description.....	1
1.2 Analysis of Wastewater System Seismic Resilience .....	1
1.3 Resilience Planning by Other Metro Region Agencies .....	2
<b>2.0 Community Resilience.....</b>	<b>3</b>
2.1 Definition .....	4
2.2 Planning Process .....	4
2.3 Seismic Hazard .....	4
<b>3.0 Level of Service Goals .....</b>	<b>8</b>
3.1 SPUR Resilient City .....	8
3.2 Oregon Resilience Plan .....	8
3.3 NIST Community Resilience Planning Guide .....	10
3.4 San Francisco Public Utilities Commission .....	11
3.5 Community Needs Following a Major Earthquake .....	11
3.6 City of Milwaukie Wastewater System Level of Service Goals.....	13
<b>4.0 City of Milwaukie Backbone System Supporting Short-Term Community Needs.....</b>	<b>15</b>
<b>5.0 Translation of Level of Service Goals into System Performance Requirements .....</b>	<b>17</b>
5.1 Considerations .....	17
5.1.1 Geotechnical Hazards.....	17
5.1.2 Effects of Aftershocks .....	17
5.1.3 Repair Difficulty .....	17
5.1.4 Availability of Public Works Department Staff .....	18
5.1.5 Availability of Design Professionals and Contractors .....	18
5.1.6 Availability of Repair Materials or Replacement Equipment. 18	
5.1.7 Infrastructure Dependencies .....	18
5.2 Wastewater System Facilities .....	20
<b>6.0 Limitations .....</b>	<b>25</b>
<b>References .....</b>	<b>26</b>

## List of Figures

Figure 2.1 – Six-Step Process to Planning for Community Resilience.....	6
Figure 2.2 – Oregon and Northern Japan Mirror Image Subduction Zones .....	7
Figure 2.3 – Historic Cascadia Subduction Zone Earthquake Timeline .....	7
Figure 4.1 – City of Milwaukie Wastewater System Backbone .....	16

## List of Tables

Table 3.1 – ORP Wastewater System Recovery Goals: Valley Zone .....	10
Table 3.2 – City of Milwaukie Recovery Goals During Short-Term Recovery Phase.....	13
Table 3.3 – City of Milwaukie Wastewater System Recovery Goals .....	14



## 1.0 Introduction and Background

### 1.1 City of Milwaukie Wastewater System Description

The City of Milwaukie wastewater system provides wastewater collection for City of Milwaukie residents and business, and small portions of the surrounding communities. The City service area is divided into seven collection basins with a total area of approximately 5 square miles. Larger diameter conveyance pipelines and wastewater treatment for the City of Milwaukie is primarily provided by Water Environment Services (WES). The City of Portland Bureau of Environmental Services (BES) provides conveyance and treatment services for wastewater collected in the Johnson Creek Basin at the northern end of the City service area.

The City owns and maintains approximately 80 miles of gravity pipelines and 1,700 manholes. These gravity pipelines range in diameter from 4 inches to 27 inches, with 81 percent of the gravity pipelines being 8 inches or less in diameter. The gravity system is augmented by five lift stations and approximately 3,500 lineal feet of force mains. The City wastewater system also includes two parallel inverted siphons (each constructed of 12-inch diameter ductile iron pipe) that cross Johnson Creek near Milwaukie Bay Park.

### 1.2 Analysis of Wastewater System Seismic Resilience

As part of the update process for the City of Milwaukie Wastewater Master Plan, the City of Milwaukie is conducting an analysis of the seismic resilience of the existing wastewater system. This project will evaluate the expected performance of selected components of the City wastewater system following a Magnitude 9.0 (M9.0) Cascadia Subduction Zone (CSZ) earthquake and identify preliminary recommendations for improvements that should be implemented to enable the City to more rapidly restore wastewater service after a major earthquake, to meet community social and economic needs. SEFT's scope of work for this wastewater system seismic resilience analysis includes:

1. Establishing Level of Service (LOS) goals for wastewater collection and conveyance following a M9.0 CSZ earthquake, based on supporting community social and economic needs;
2. Developing facility structural and nonstructural performance objectives to support achievement of LOS goals;
3. Working with the WSC team to identify the wastewater collection and conveyance system backbone required to support short-term community social and economic needs;
4. Reviewing as-built construction drawings and any available retrofit drawings, calculations, and reports for two critical lift stations that are to be evaluated as part of this project;

5. Conducting a site visit to perform visual observation of the two critical lift stations;
6. Performing structural and nonstructural seismic evaluation of two critical lift stations using the Tier 1 checklist-based screening procedure of ASCE 41-17 *Seismic Evaluation and Retrofit of Existing Buildings* (ASCE, 2017b) supplemented by TCLEE Monograph 22 *Seismic Screening Checklists for Water and Wastewater Facilities* (Heubach, 2003);
7. Developing preliminary recommendations to mitigate the structural and nonstructural deficiencies identified for the two critical lift stations; and
8. Coordinating with WSC to discuss potential consequence of failure of the two critical lift stations on collection and conveyance system operability.

This Technical Memorandum (TM) presents SEFT’s recommendations related to scope items 1 through 3.

### **1.3 Resilience Planning by Other Metro Region Agencies**

The resilience planning effort being undertaken by the City of Milwaukie is similar to the planning activities undertaken by several Portland metro region agencies. Additionally, numerous other agencies on the west coast of the United States and Canada are actively conducting resilience planning and resilience-based capital improvement projects.

#### ***Clean Water Services***

Clean Water Services has developed treatment process-based level of service goals for their Rock Creek Advanced Wastewater Treatment Facility, performed a preliminary assessment of the expected seismic performance of the facility, and developed a long-term strategy for implementing seismic resilience improvements.

#### ***City of Portland***

The Portland Water Bureau has completed a water system resilience planning project and is beginning to incorporate recommendations from the plan into their capital improvement projects. The Bureau of Environmental Services has completed a wastewater system seismic resilience master plan and has already begun to incorporate early action item recommendations into practice.

#### ***City of Gresham***

The City of Gresham has completed resilience planning projects for both their water and wastewater systems and are beginning to incorporate recommendations from these plans into their capital improvement projects. They have successfully leveraged their water system resilience plan to obtain Federal Emergency Management Agency pre-disaster mitigation grant funding to implement seismic improvements at one of their water reservoirs.

## 2.0 Community Resilience

Events like Hurricane Katrina in 2005, the Great East Japan M9.0 Earthquake and Tsunami in 2011, and Hurricane Sandy in 2012 have underscored the devastating impacts that natural disasters can inflict at a local, regional, state, and multi-state level. The Federal government has defined the National Preparedness Goal as: “A secure and resilient Nation with the capabilities required across the whole community to prevent, protect against, mitigate, respond to, and recover from the threats and hazards that pose the greatest risk” (FEMA, 2015).

One strategy to achieve this National Preparedness Goal is to plan for and implement programs and strategies to improve disaster resilience at the local, regional, state, and national level. Oregon is a national leader in community resilience. In February of 2013, the Oregon Seismic Safety Policy Advisory Commission submitted a report to the 77<sup>th</sup> Legislative Assembly entitled the *Oregon Resilience Plan: Reducing Risk and Improving Recovery for the Next Cascadia Earthquake and Tsunami* (OSSPAC, 2013). The report discussed the risk that is faced by the citizens of Oregon from an impending Cascadia Subduction Zone earthquake and accompanying tsunami, and the gaps that exist between the current state of Oregon’s infrastructure and where it needs to be. In addition to life safety impacts, the report also highlighted the economic vulnerabilities to individuals and communities from such an event. The *ORP* went on to outline steps that can be taken over the next 50 years to bring the state closer to resilient performance through a systematic program of vulnerability assessments, capital investments in public infrastructure, new incentives to engage the private sector, and policy changes that reflect current understanding of the Cascadia threat. While the *ORP* specifically addresses improving resilience in the aftermath of a major earthquake, implementation of the plan is also expected to improve resilience for other hazards.

A primary focus of the *ORP* goals is to minimize the long-term economic damage associated with the potential out-migration of businesses and population that would be expected to occur following a major disaster, if basic services cannot be restored rapidly enough to meet the communities social and economic needs. Resilience of the wastewater system will be key to the region’s economic recovery. For example, the fundamental goal of rapidly controlling threats to public health and safety by containing and routing raw sewage away from the public will help to enable residents to shelter-in-place and businesses to resume operation as quickly as possible after the event. Small businesses are particularly vulnerable to being closed for an unplanned amount of time and many may not be able to re-open if closed for more than a month. Each business closing negatively impacts employment, tax revenue, and the long-term economic and social viability of the City. The more rapidly that businesses are able to reopen, the quicker revenue will normalize, and money will circulate within the region’s economy. At a fundamental level, the wastewater system must be functioning at a certain level for service fees to be collected to provide revenue for the City of Milwaukie to sustain everyday functions and to help fund the recovery process.

## 2.1 Definition

In the field of community disaster planning, a common definition of “resilience” has been put forth by Presidential Policy Directive (PPD). PPD-8 (2011) defines resilience as “the ability to adapt to changing conditions and withstand and rapidly recover from disruption due to emergencies.” PPD-21 (2013) refined the definition to “...the ability to prepare for and adapt to changing conditions and to withstand and recover rapidly from disruptions. Resilience includes the ability to withstand and recover from deliberate attacks, accidents, or naturally occurring threats or incidents.”

## 2.2 Planning Process

While varied forms of community disaster preparedness planning have been taking place for decades, a specific focus on community resilience has developed over about the last 10 years. In 2015, the National Institute of Standards and Technology (NIST) published NIST Special Publication 1190, *Community Resilience Planning Guide for Buildings and Infrastructure Systems* (NIST, 2015). The *Guide* outlines a consistent framework for a six-step resilience planning process (see Figure 2.1) that is designed to be conducted at a community level, involving broad representation from local and regional government, building owners, infrastructure system owner/operators, and community representatives. The *Guide* process can also be adapted to resilience planning for a specific infrastructure system (e.g. wastewater system), with some limitations. One of the main limitations of an individual infrastructure system planning approach is that it requires assumptions to be made that can’t be tested with community stakeholders and other infrastructure system providers. For instance, operation of wastewater lift stations requires commercial electrical power or emergency generators with adequate fuel supplies. The timeline for restoration of commercial electrical power or availability of fuel for generators is largely controlled by stakeholders that aren’t involved in a wastewater system only planning scenario.

## 2.3 Seismic Hazard

One of the initial steps in the resilience planning process involves determining the specific hazards to be safeguarded against. As indicated in the City’s addendum to the Clackamas County Multi-Jurisdictional Natural Hazard Mitigation Plan (City of Milwaukie, 2020), the City of Milwaukie has identified a CSZ earthquake as their top hazard. Therefore, consistent with the *ORP*, the City of Milwaukie has selected a M9.0 CSZ scenario earthquake as the hazard to be explicitly considered for this seismic resilience study.

The geologic and seismologic information available for identifying the potential seismicity throughout the State of Oregon is continually evolving, and large uncertainties are associated with estimates of the probable magnitude, location, and frequency of occurrence of earthquakes. The available information indicates the potential seismic sources that may affect the state can be grouped into three categories:

- Subduction zone events related to sudden slip between the upper surface of the Juan de Fuca plate and the lower surface of the North American plate,
- Subcrustal events related to deformation and volume changes within the subducted mass of the Juan de Fuca plate, and
- Local crustal events associated with movement on shallow, local faults.

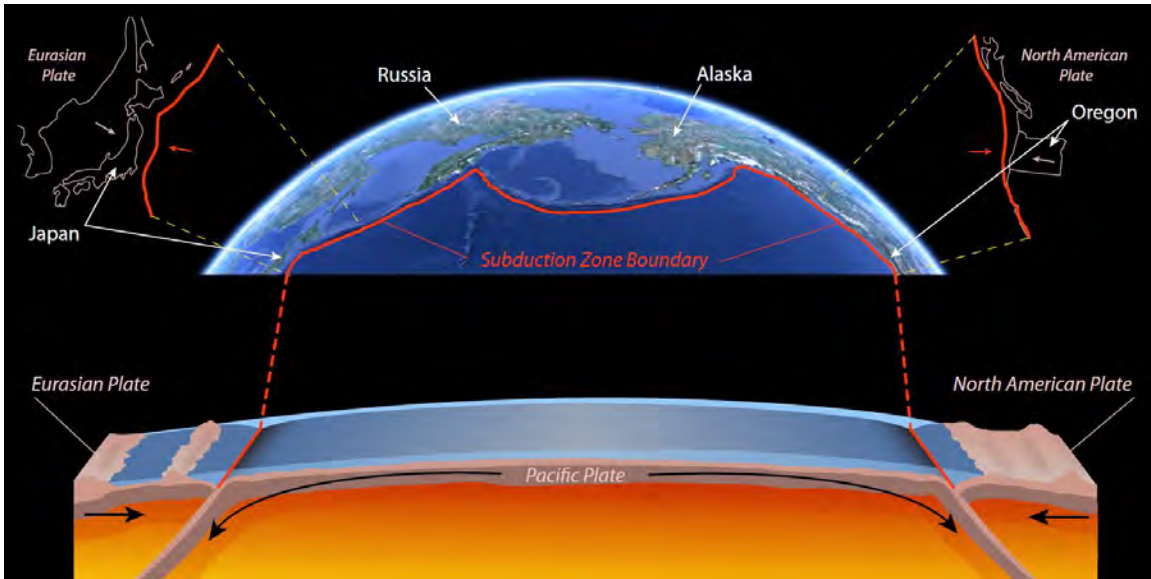
A major contributor to the seismic hazard in western Oregon is the Cascadia Subduction Zone (CSZ) that lies off the coast of Oregon, Washington, Northern California, and British Columbia. The CSZ is an active plate boundary along which the remnants of the Farallon Plate (the Gorda, Juan de Fuca and Explorer plates) are being subducted beneath the western edge of the North American continent. Figure 2.2 shows that the subduction zone off the coast of Oregon is a mirror image of the subduction zone off the coast of Northern Japan that produced the deadly Magnitude 9.0 Tohoku earthquake in 2011. Seismologists anticipate that the strong shaking from a CSZ earthquake will last from 3 to 5 minutes, much longer than the 30-second strong shaking experienced in a typical California earthquake.

Seismologists' understanding of the damaging earthquakes produced by the CSZ has steadily increased over the past 25 years. Research by the Oregon Department of Geology and Mineral Industries (DOGAMI), Oregon State University, and others has provided evidence of the timeline of historic great CSZ earthquakes. The timeline of these 41 earthquakes over the last 10,000 years is provided in Figure 2.3, showing that past earthquakes have occurred at highly variable intervals, and can range widely in size and in which parts of the Pacific Northwest they affected. The rupture distance for these CSZ earthquakes varies from a short rupture along the Northern California and Southern Oregon Coast, to a rupture along the entire length of the subduction zone from Northern California to British Columbia. There is about a 37 percent chance in the next 50 years of a Magnitude 8+ earthquake originating on the southern portion of the CSZ and up to a 15 percent chance in the next 50 years of a great earthquake affecting the entire Pacific Northwest. The scenario involving rupture of the Northern Oregon portion would significantly impact all of Western Oregon, including Milwaukie.

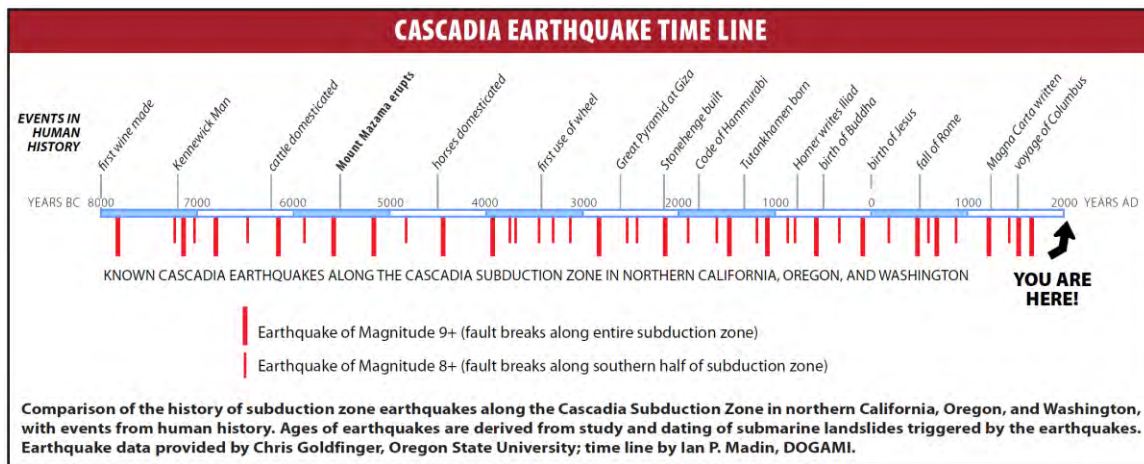




Figure 2.1 – Six-Step Process to Planning for Community Resilience (NIST, 2015)



**Figure 2.2 – Oregon and Northern Japan Mirror Image Subduction Zones (OSSPAC, 2013)**



**Figure 2.3 – Historic Cascadia Subduction Zone Earthquake Timeline (DOGAMI, 2010)**

### 3.0 Level of Service Goals

Resilience planning involves establishing level of service (LOS) goals to define system performance expectations after being impacted by the hazard under consideration. These LOS goals could be simple, such as maintain service for 100 percent of customers during a routine winter storm that disrupts commercial electrical power for 24 hours, or they may be more complex for more damaging hazards like major earthquakes. This section presents examples of LOS goals included in other plans and then describes the LOS goals suggested for adoption by the City of Milwaukie for the wastewater system.

#### 3.1 SPUR Resilient City

In one of the first studies of its kind, the San Francisco Planning + Urban Research Association (SPUR) developed a series of policy papers aimed at raising awareness of how San Francisco’s buildings and lifeline infrastructure are likely to perform in an expected earthquake and identifying actions that could be implemented before an earthquake to improve the City’s resilience. The report outlined the importance of how the restoration timeline for water, wastewater, electrical power, and other lifeline systems impacts the speed with which a community can return to normal after a major disruption (SPUR, 2009). The report established the goals of restoring lifeline services to: 1) 90 percent of customers within 72 hours, 2) 95 percent of customers within one month, and 3) 100 percent of customers within four months after an expected level earthquake. It is assumed that critical facilities (e.g., hospitals, emergency operations centers, etc.) would be included in the 90 percent of customers restored within 72 hours. For buildings, the SPUR report defines the expected level earthquake as one having a 10 percent probability of occurring in a 50-year period and compares it to a magnitude 7.2 earthquake on the peninsula segment of the San Andreas Fault. The SPUR report also indicated that for lifeline systems, that typically have a longer design life than buildings, a larger expected level earthquake should be considered.

#### 3.2 Oregon Resilience Plan

The threat of a Cascadia earthquake is a significant enough physical, economic, and social risk in the Pacific Northwest that in 2012 and 2013, at the request of the State of Oregon Legislative Assembly, the Oregon Seismic Safety Policy Advisory Commission (OSSPAC) and a team of volunteer professionals developed the *Oregon Resilience Plan: Reducing Risk and Improving Recovery for the Next Cascadia Earthquake and Tsunami* (OSSPAC, 2013). The *ORP* outlines steps that can be taken over a 50-year period to bring the state closer to resilient performance through a systematic program of vulnerability assessments, capital investments in buildings and infrastructure systems, new incentives to engage the private sector, and policy changes that reflect current understanding of the Cascadia threat to our community and economy.

OSSPAC assembled eight task groups, comprising over 160 volunteer subject-matter experts from government, universities, the private sector, and the general public. Task Groups included: (1) Cascadia earthquake scenario, (2) business and workforce continuity, (3) coastal communities, (4) critical and essential buildings, (5) transportation, (6) energy, (7) information and communications, and (8) water and wastewater. Task Group activities were overseen by OSSPAC and an Advisory Group. Each Task Group was charged to:

- Determine the likely impacts of a Magnitude 9.0 Cascadia earthquake and tsunami on its assigned sector, and estimate the time required to restore functions in that sector if the earthquake were to strike under present conditions;
- Define acceptable timeframes to restore functions after a future Cascadia earthquake to fulfill expected resilient performance; and
- Recommend changes in practice and policies that, if implemented during the next 50 years, will allow Oregon to reach the desired resilience targets.

The various task groups used estimates of the seismic hazard and expected ground motions developed by the Cascadia Earthquake Scenario Task Group in combination with knowledge of the construction era and condition of existing infrastructure to estimate the expected performance and service restoration times if the scenario event were to occur at the time the *ORP* was being developed.

The *ORP* used the SPUR model as a starting point for developing LOS goals (target timelines for restoration of services) after a Cascadia earthquake. These restoration targets were established assuming system resilience enhancements would be implemented over the following 50 years. These targets were set for three levels of service:

- Minimal level of service restored for the use of emergency response;
- Functional level of service up to 50 percent of capacity that is sufficient to get the economy moving again, and an
- Operational level of service where restoration is up to 90 percent of capacity (which may still rely on temporary fixes).

Table 3.1 summarizes the *ORP*'s goals for the restoration of wastewater service for the Willamette Valley (after 50 years of resilience improvements) and compares it to the expected performance if the earthquake were to have occurred at the time the *ORP* was written. The time differences between the *ORP* restoration target (LOS) goal and expected performance illustrates the resilience gaps that require investment in infrastructure improvements, and public policy enhancements over the coming years.

**Table 3.1 – ORP Wastewater System Recovery Goals: Valley Zone  
 (adapted from OSSPAC 2013)**

	0-24 hours	1-3 days	3-7 days	1-2 weeks	2-4 weeks	1-3 months	3-6 months	6-12 months	1-3 years	3+ years
Threats to public health & safety controlled		R	Y		G			X		
Raw sewage contained & routed away from population	R		Y			G		X		
Treatment plants operational to meet regulatory requirements				R			Y	G		X
Major trunk lines and pump stations operational				R		Y	G			X
Collection system operational						R	Y	G	X	

**Key to Table**

*Target Timeframe for Recovery:*

Desired time to restore components to 20-30% operational



Desired time to restore components to 50-60% operational



Desired time to restore components to 80-90% operational



Current state (90% operational)



### 3.3 NIST Community Resilience Planning Guide

The authors of the NIST *Guide* built upon the framework established by SPUR and the *ORP* in developing recommendations for community resilience planning. The categories, for which restoration timeline goals should be set, were further expanded to consider additional system components and to clarify that restoration timelines will likely vary based on the building cluster that is being supported (critical facilities, emergency housing, housing/neighborhoods, etc.). The *Guide* does not make recommendations for recovery timelines but provides a framework that communities can use to collectively establish these recovery timeline goals. The expanded *Guide* performance goal table along with the restoration timeline goals established by the *ORP* have been used in developing level of service goals for this project. Further description of the recommended City of Milwaukie wastewater system level of service goals developed as part of this project is provided in Section 3.6.



### 3.4 San Francisco Public Utilities Commission

The San Francisco Public Utilities Commission (SFPUC) outlines seismic design requirements in an agency specific engineering standard, *General Seismic Requirements for Design of New Facilities and Upgrade of Existing Facilities* (SFPUC, 2014). The purpose of the Standard is “to set forth consistent criteria for the seismic design and retrofit of San Francisco’s water and wastewater infrastructures. These systems comprise buildings, aboveground and underground piping, retaining walls, underground structures, tanks and basins, dams and reservoirs, special structures, and equipment under the jurisdiction of the SFPUC.”

The SFPUC standard establishes that the wastewater treatment basic level of service goal is to re-establish dry-weather primary treatment levels within 72 hours after a major earthquake. For critical and non-redundant structures and components, this major earthquake is defined as having a 5 percent probability of exceedance in 50 years (975-year return period). The basic level of service goal also considers several supplemental criteria that include (SFPUC, 2014):

- **Redundancy:** Critical functions are built with 100 percent redundant infrastructure. Strengthening critical structures and providing alternative flow routing will minimize possible impacts to public health and receiving waters in the immediate aftermath of a significant earthquake;
- **Regulatory Requirements:** Full compliance with state and federal regulatory requirements applicable to the treatment and disposal of sewage and storm water;
- **Storm Management:** Control and manage flows from a storm of 3-hour duration that delivers 1.3 inches of rain; and
- **Sea Level Rise:** New infrastructure must accommodate expected sea level rise within the service life of the asset (i.e., 16 inches by 2050, 25 inches by 2070, and 55 inches by 2100).

### 3.5 Community Needs Following a Major Earthquake

To support the region’s economic and community recovery after a major disaster, infrastructure services are required to be restored as the building clusters that rely on these services come back online (i.e., a building that will take six months to reopen due to repair of structural damage doesn’t need wastewater service until the end of that six months). In some cases, like that for smaller businesses, an outage of critical services like wastewater for more than a few weeks may mean a business cannot return to operation. The current expectation of many Oregonians is that wastewater service will be restored within one month after a major earthquake (City Club, 2017). The wastewater system recovery goals suggested in the *ORP* propose a longer duration for recovery to the 80-90% operational level than this public expectation. However, the *ORP* also sets goals for partial recovery in the initial days and weeks after a major earthquake with the aim of supporting rapid economic and social recovery.

Given that it would be cost prohibitive to eliminate all earthquake damage, a fundamental short-term community need will be to provide wastewater collection for hospitals, emergency shelters, and other similar facilities. Immediately after the event, it is anticipated that the City of Milwaukie will focus on repairing any damage to the wastewater system supporting these critical customers and then quickly transition to restoring wastewater service to other customers. The goal for rapidly controlling threats to public health and safety by containing and routing raw sewage away from the public will help support the Milwaukie Community’s desire that residents will be able to shelter-in-place in their homes immediately after a major earthquake and that they will be able to resume a semi-normal daily routine after two to four weeks by returning to school/work, shopping at their local grocery store, receiving medical care at their local clinic, etc. All these normal activities involve the generation of wastewater. At first, it is expected that temporary measures will be required for wastewater collection, but as the weeks progress, more permanent fixes will be implemented and the temporary measures will slowly disappear.

Table 3.2 provides a breakdown of restoration priorities for City customers that was jointly developed in a collaborative workshop conducted with the WSC team and City of Milwaukie staff, based upon the critical and essential community facilities identified in the City’s addendum to the Clackamas County Multi-Jurisdictional Natural Hazard Mitigation Plan (City of Milwaukie, 2020). The table links social/economic needs to restoration timeline goals within the short-term recovery phase [short-term (no disruption), short-term (1-3 days), and short-term (3-7 days)]. Note that these restoration timeline goals have been established based on our current understanding of the community’s social and economic needs, without consideration or knowledge of the current expected seismic performance of these existing community facilities. In order to support community social and economic needs on a timeline that is similar to that proposed for the wastewater system, many of these community facilities may need to be seismically retrofit or replaced with new buildings designed with a higher structural and nonstructural performance objective. If a facility that is critical to supporting short-term community social/economic needs is relocated, site selection criteria for the new location should consider proximity to the wastewater system backbone or the wastewater system backbone should be appropriately modified to include the location of the new facility.

**Table 3.2 – City of Milwaukie Recovery Goals During Short-Term Recovery Phase**

Response/Recovery Phase	Social/Economic Needs
<p align="center"><b>Short-Term (no disruption)</b></p>	<ul style="list-style-type: none"> <li>• Providence Milwaukie Hospital</li> </ul>
<p align="center"><b>Short-Term (1-3 days)</b></p>	<ul style="list-style-type: none"> <li>• Public Safety Building                             <ul style="list-style-type: none"> <li>○ Clackamas Fire District Station 2</li> <li>○ City of Milwaukie Police Station</li> <li>○ City EOC</li> </ul> </li> <li>• Milwaukie City Hall</li> <li>• Johnson Creek Building (Public Works)</li> </ul>
<p align="center"><b>Short-Term (3-7 days)</b></p>	<ul style="list-style-type: none"> <li>• Emergency Shelters                             <ul style="list-style-type: none"> <li>○ Rowe Middle School</li> <li>○ Milwaukie High School</li> <li>○ Milwaukie Center</li> <li>○ Eagles Wings Ministries</li> <li>○ Milwaukie Presbyterian Church</li> </ul> </li> <li>• Vulnerable Populations                             <ul style="list-style-type: none"> <li>○ Annie Ross House</li> <li>○ Hillside Manor</li> <li>○ Johnson Creek Treatment Facility</li> <li>○ Lockdown Facility (9200 SE McBrod Ave.)</li> <li>○ Prestige Post-Acute and Rehab Center</li> <li>○ Royal Marc Retirement Residence</li> <li>○ Senior Center (Rusk Rd. near North Clackamas Park)</li> </ul> </li> </ul>

### 3.6 City of Milwaukie Wastewater System Level of Service Goals

The *ORP* was developed assuming a three-tiered LOS goal approach to implement a phased restoration of services and help define the speed of recovery for a community’s infrastructure systems. The *ORP* recommended a timeline for these three-tiered LOS goals but provided the flexibility for an individual utility to define how the levels of functional restoration are to be achieved for their specific system. The LOS (i.e., restoration timeline) goals proposed for adoption by the City of Milwaukie align with those presented in the *ORP* and are augmented by additional considerations suggested by the *NIST Guide*. Table 3.3 summarizes these goals for the City of Milwaukie wastewater system, including information about the recommended definition of 30%, 60%, and 90% operational for City of Milwaukie wastewater system infrastructure. For example, the 90% operational goal for hospital facilities has been defined to mean that the City of Milwaukie wastewater system is capable of routing 90% of the flow generated by hospitals to a wastewater treatment plant.

**Table 3.3 – City of Milwaukie Wastewater System Recovery Goals  
(adapted from OSSPAC 2013 and NIST 2015)**

Wastewater Systems	Target Timeframe for Recovery								
	Phase 1: Short-Term			Phase 2: Intermediate			Phase 3: Long-Term		
	Days			Weeks			Months		
	0-1	1-3	3-7	1-2	2-4	4-12	3-6	6-9	9-12
<b>Major Trunk Lines and Associated Lift Stations</b>									
Backbone conveyance facilities (major trunk line, lift station, etc.)			Backbone Capable of Routing 30% AWWF <sup>1</sup> to Treatment Plants			Backbone Capable of Routing 60% AWWF to Treatment Plants		Backbone Capable of Routing 90% AWWF to Treatment Plants	
<b>Control Systems</b>									
SCADA and other control systems								90% Operational	
<b>Collection Lines and Associated Lift Stations</b>									
<b>Critical Facilities</b>									
Hospitals, EOC, Police Stations, Fire Stations		90% of Generated Flow Routed to Treatment Plants							
<b>Emergency Housing</b>									
Emergency Shelters			90% of Generated Flow Routed to Treatment Plants						
<b>Housing/Neighborhoods</b>									
Threats to public health and safety controlled by containing and routing raw sewage away from public		30% of Generated Flow Routed to Treatment Plants	60% of Generated Flow Routed to Treatment Plants		90% of Generated Flow Routed to Treatment Plants				
<b>Community Recovery Infrastructure</b>									
All other clusters							30% of Customer Connections Restored	60% of Customer Connections Restored	90% of Customer Connections Restored

<sup>1</sup>AWWF = Average Wet Weather Flow

**Key to Table**

Desired time to restore components to 30% operational

R

Desired time to restore components to 60% operational

Y

Desired time to restore components to 90% operational

G

## 4.0 City of Milwaukie Backbone System Supporting Short-Term Community Needs

Satisfying short-term LOS restoration timeline goals requires critical components of the City wastewater collection and conveyance system to remain operational or experience only minor damage after a major earthquake. These critical system components usually include: small diameter collection pipelines and associated lift stations that connect to critical and essential facilities (hospitals, emergency shelters, etc.), large diameter conveyance pipelines (12 inches and larger) and associated lift stations, and certain support facilities (maintenance shops, etc.). If an assessment of these critical system components reveals any gaps between the expected performance and that required to achieve the LOS goals, then these deficient components should be seismically retrofit or replaced, as appropriate.

The WSC team has collaborated with the City of Milwaukie to identify the proposed backbone for the City wastewater system shown in Figure 4.1. The backbone system provides a continuous wastewater collection system flow path between facilities that are required to meet short-term community needs (see Table 3.2) and the WES or BES wastewater conveyance systems, as appropriate. The backbone systems proposed for the City of Milwaukie wastewater system is consistent with that envisioned during the development of the *ORP*. The backbone includes elements of the wastewater system that are required to meet short-term LOS restoration timeframe goals in the initial days after a major earthquake. Since it would be challenging to implement any significant repairs to the backbone system in the initial days after an earthquake, the elements of the backbone system should be designed or retrofit such that they experience only minor or no geotechnical, structural, and nonstructural related damage during a major earthquake.



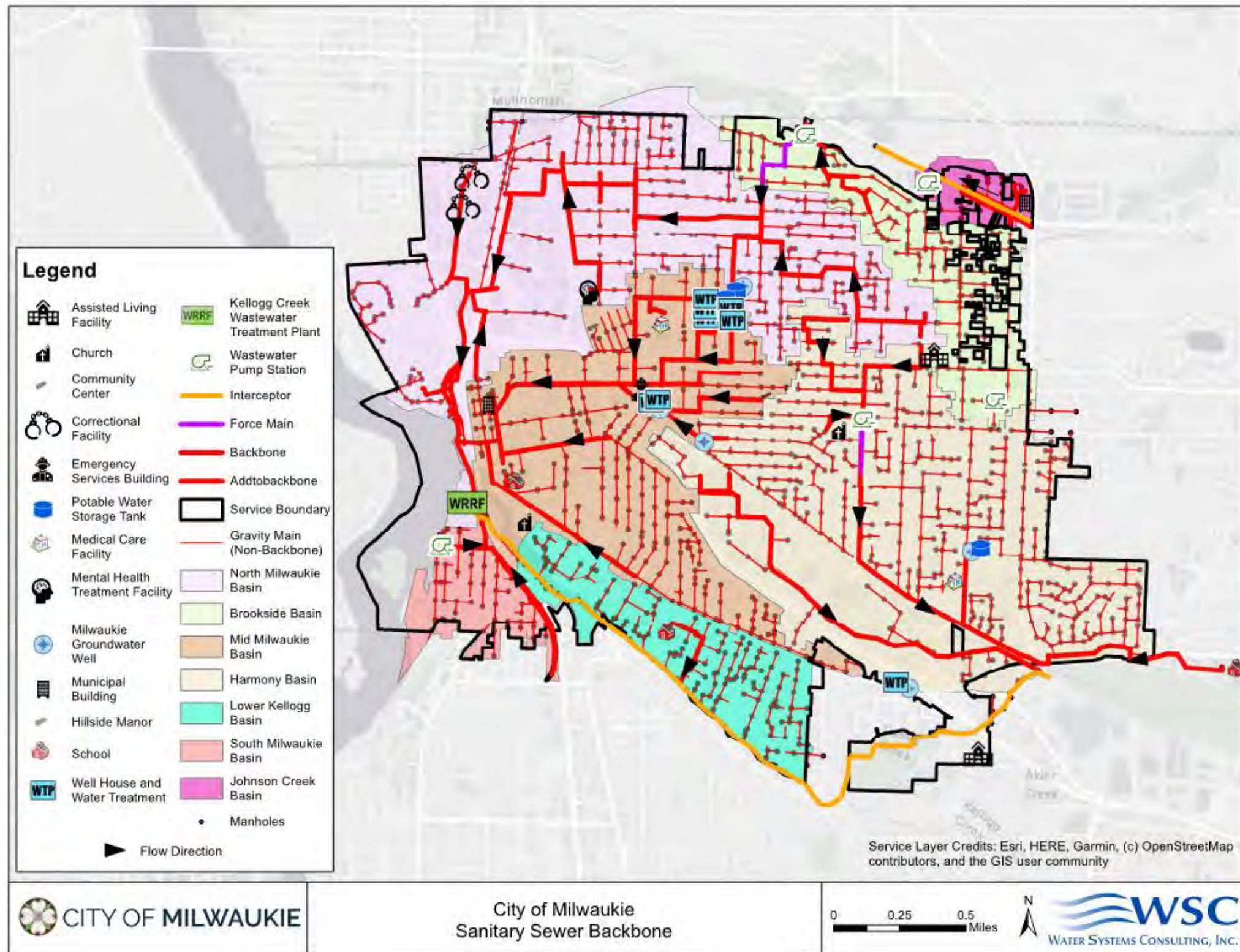


Figure 4.1 – City of Milwaukie Wastewater System Backbone

## **5.0 Translation of Level of Service Goals into System Performance Requirements**

Several factors need to be taken into consideration when translating the City of Milwaukie LOS goals into performance requirements for the seismic design or retrofit of wastewater system components. Section 5.1 describes several of the factors that have been considered in developing the recommended general performance requirements detailed in Section 5.2.

### **5.1 Considerations**

The following subsections describe factors considered in developing performance requirements for the various components of the City of Milwaukie wastewater system. For future wastewater system projects, these factors should also be evaluated on a project-specific basis to determine if there are any unique features of the project that require modification of the general seismic resilience-based performance requirements.

#### **5.1.1 Geotechnical Hazards**

Observations from past earthquakes have indicated that geotechnical hazards are a major contributing factor to the expected post-earthquake performance of wastewater systems. Infrastructure that is exposed to liquefaction, lateral spreading, or landslide geotechnical hazards requires special design considerations that include either mitigation measures to address the geotechnical hazard or predetermined work-arounds to bypass components that may fail during an earthquake. Wastewater collection and conveyance piping that crosses creeks or other low-lying areas can be particularly vulnerable to damage from earthquake-induced liquefaction and lateral spreading.

#### **5.1.2 Effects of Aftershocks**

Major earthquakes are often accompanied by numerous aftershocks. In the 2011 Tohoku Japan earthquake two major aftershocks caused additional damage to infrastructure systems, resulting in relapses in the number of customer outages (Nojima, 2012). It may be necessary to reevaluate system components and/or perform additional repairs after major aftershocks.

#### **5.1.3 Repair Difficulty**

Certain wastewater system components (like large diameter conveyance pipelines) may be very difficult to repair after an earthquake. If a component is anticipated to be difficult to repair and it is also important to system performance, then it should be designed to minimize any potential earthquake damage that would impact the functionality of the component. Other assets of this type could include pipes under railroad tracks or highways.



#### **5.1.4 Availability of Public Works Department Staff**

The first priority for many City of Milwaukie Public Works Department staff in the initial hours and days following a major earthquake will be to ensure the health and safety of their families. Once those critical needs are addressed, City of Milwaukie Public Works Department staff will, ideally, be available to report to work. However, even after they return to work, it is possible that the City Emergency Manager may assign Public Works Department staff to work on non-wastewater system related tasks that are deemed more critical to the City's disaster response activities. This scenario suggests that Public Works Department staff may have limited ability to perform repairs or implement predetermined work-arounds in the initial hours and days after an earthquake. Critical components of the wastewater system that are required to be operational within the first 3-7 days after an earthquake should be designed or seismically retrofitted to remain operational during and immediately after a major earthquake.

#### **5.1.5 Availability of Design Professionals and Contractors**

The restoration timeline goals and required repairs must be in line with the anticipated availability of qualified design professionals and contractors to design and implement the repairs. It is anticipated that the design and construction of major repairs to a lift station would take between 6-12 months. It is anticipated that the design and construction that replaces a lift station would take a minimum of 18 months. These timeframes may increase if the City decides to rebuild the lift stations to a higher standard of performance, i.e., a resilient design, which may require more planning and design time.

#### **5.1.6 Availability of Repair Materials or Replacement Equipment**

The City of Milwaukie maintains limited supplies of emergency repair materials, but these supplies are not anticipated to be adequate for the number of repairs that may be necessary after a major earthquake. For disasters that impact a relatively small geographic region, it is possible that other nearby utilities could lend repair supplies. However, a CSZ earthquake will impact the entire Pacific Northwest (from Northern California to British Columbia) and relying on neighboring utilities as a potential source for repair materials is likely impractical.

Additionally, some equipment used in lift stations is not available from manufacturer's stock and has a long lead time for production. Special consideration must be given to this difficult-to-source equipment to ensure that it is either not damaged during an earthquake, a predetermined work-around has been established, or the equipment manufacturing lead time aligns with restoration timeline goals.

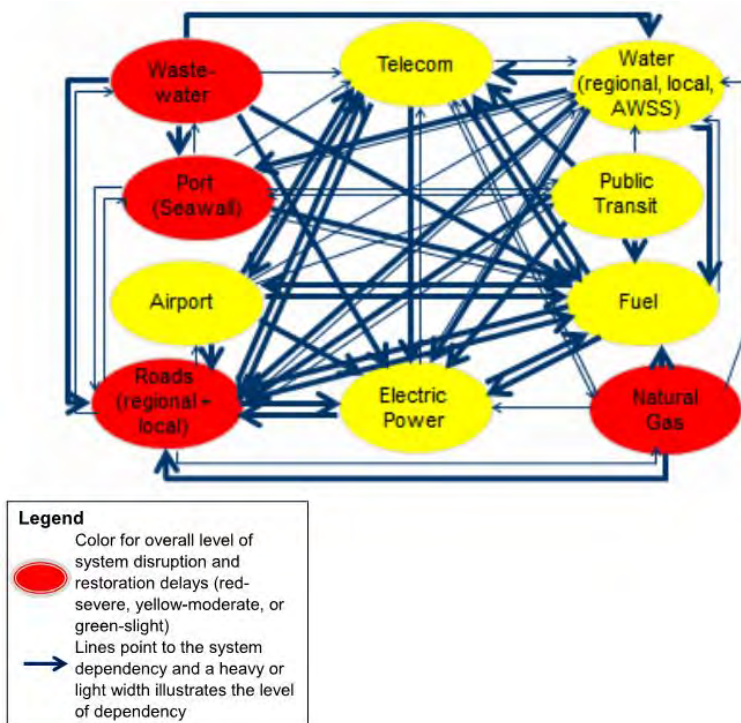
#### **5.1.7 Infrastructure Dependencies**

The restoration of wastewater system infrastructure is highly dependent on other infrastructure systems. Examples of these dependencies include:

- Co-location with and damage to other lifeline systems (roads, bridges, wastewater pipes, etc.);

- Liquid fuel availability for trucks, generators, and equipment;
- Commercial electrical power;
- Transportation system for delivery of repair materials and mutual aid assistance crews; and
- Cellular communications system for coordination of City of Milwaukie staff and contractors.

The level of service goals and performance requirements suggested in this report assume that all lifeline service providers will be making significant investments in the earthquake resilience of their systems in the next 45 years. If one or more lifeline sectors do not make these system improvements, then the speed of community recovery could be greatly impacted because of the dependencies between all infrastructure systems. Figure 5.1 shows an example of the complicated dependency relationships among lifelines in the San Francisco Bay Area (City and County of San Francisco Lifelines Council, 2014). Heavy and light lines widths depict the relative level of dependencies anticipated to occur between the various lifelines systems following a scenario M7.9 earthquake on the San Andreas fault.



**Figure 5.1 – Lifeline Interdependencies in the San Francisco Bay Area (City and County of San Francisco Lifelines Council, 2014)**

## 5.2 Wastewater System Facilities

Wastewater system facilities (lift stations, etc.) are designated as Risk Category III structures according to the requirements of the latest edition of the *Oregon Structural Specialty Code* (OSSC, 2019). These facilities are designed to a higher standard than typical commercial and residential structures that are designated as Risk Category II. Water system facilities that are required for fire suppression, hospitals, police and fire stations, and other essential facilities are designated at Risk Category IV and are designed for seismic performance that is one step above Risk Category III and two steps above Risk Category II. For new structures, the construction cost increase associated with elevating the design standard from Risk Category III to Risk Category IV is typically relatively minor. Therefore, it is recommended that all new wastewater system structures should be designed per the more stringent *Oregon Structural Specialty Code* seismic design requirements for Risk Category IV structures. Also, since geotechnical hazards (e.g., liquefaction and lateral spreading, etc.) can significantly impact the performance of wastewater system structures following a major earthquake, it is recommended that site-specific geotechnical investigations and analysis be conducted to characterize these potential hazards. Wastewater system structure designs should include appropriate measures to mitigate these potential site-specific geotechnical hazards. Equipment associated with wastewater system structures should be adequately braced and seismically certified, per the requirements of the latest edition of ASCE 7, *Minimum Design Loads for Buildings and Other Structures* (ASCE, 2017a), so that it could remain operational after a design level earthquake, as long as dependent systems are also functional [e.g., electrical power (emergency generator or commercial), etc.]. Piping entering or exiting wastewater system structures should be designed to accommodate the anticipated earthquake-induced relative movement between the structure and surrounding soil.

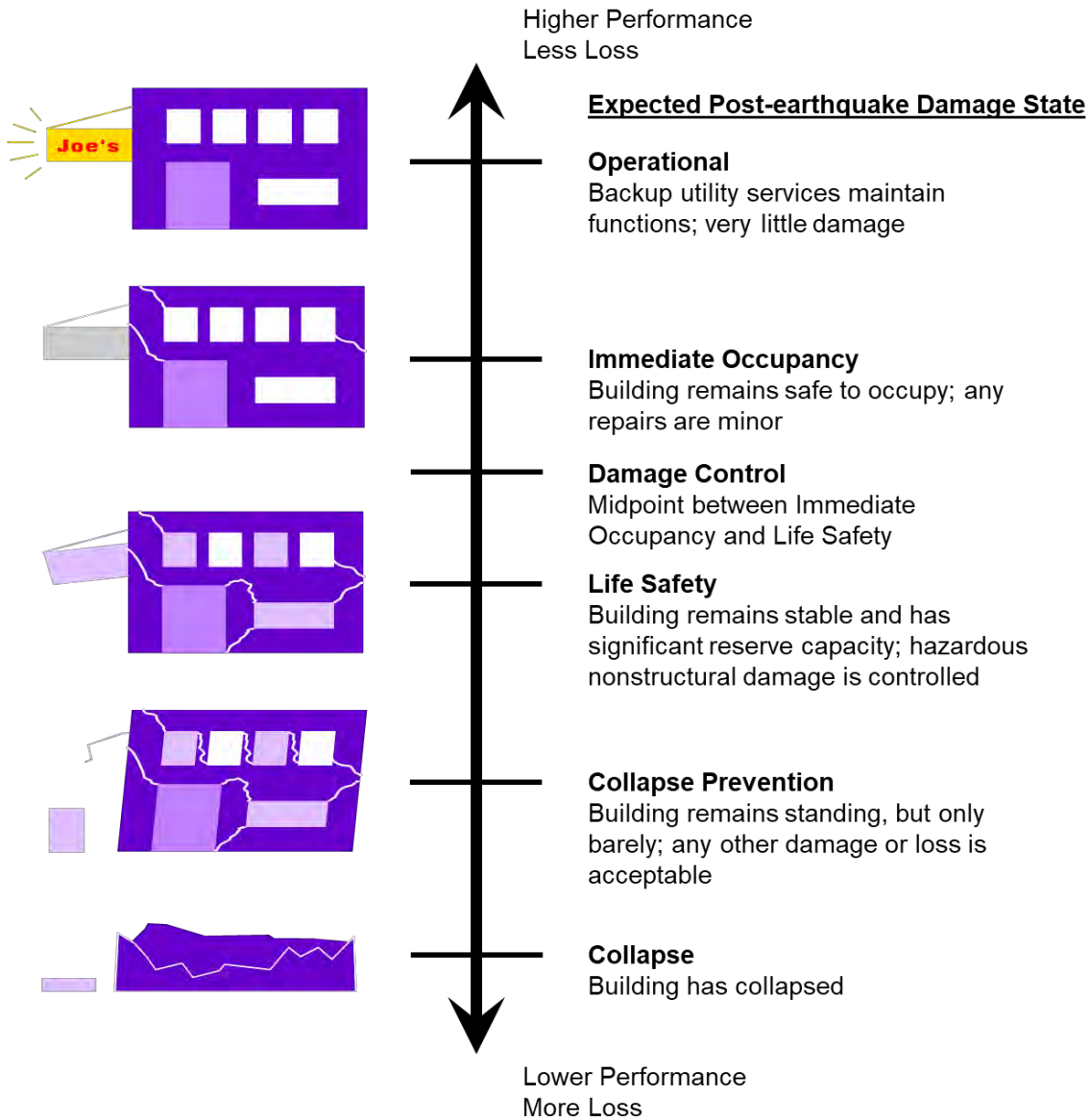
In order to meet the target LOS goals, wastewater system facilities need to meet or exceed defined levels of structural and nonstructural seismic performance. ASCE 41-17, *Seismic Evaluation and Retrofit of Existing Buildings* (ASCE, 2017b), presents several structural and nonstructural seismic performance objectives and describes the expected level of earthquake damage associated with each performance objective. Also included are expectations about the operability and reparability of earthquake damage for these various performance objectives. The ASCE 41-17 descriptions of these performance objectives are provided below and summarized in Figure 5.2. Table 5.1 provides a comparison between these performance objectives and the intended performance associated with *Oregon Structural Specialty Code* Risk Categories.



**Table 5.1 – Comparison of Seismic Performance Objectives with OSSC Risk Categories**

Risk Category	Performance Objective <sup>a</sup>	
	Structural	Nonstructural
IV	Immediate Occupancy	Operational
III	Damage Control	Position Retention
I & II	Life Safety	Position Retention

<sup>a</sup> For the BSE-1N seismic hazard level as defined by ASCE 41-17



**Figure 5.2 – Building Performance Objectives  
 (adapted from ASCE, 2017b)**

### *Structural Performance Objectives*

**Immediate Occupancy:** “Immediate Occupancy” refers to the post-earthquake damage state in which only very limited structural damage has occurred. The basic vertical- and lateral-force-resisting systems of the building retain almost all their pre-earthquake strength and stiffness. The risk of life-threatening injury from structural damage is very low, and although some minor structural repairs might be appropriate, these repairs would generally not be required before re-occupancy. Continued use of the building is not limited by its structural condition but might be limited by damage or disruption to nonstructural elements of the building, furnishings, or equipment and availability of external utility services.

**Damage Control:** “Damage Control” refers to a midway point between Life Safety (see next description) and Immediate Occupancy (see previous description). This performance objective is intended to provide a structure with a greater reliability of resisting collapse and being less damaged than a typical structure, but not to the extent required of a structure designed to meet the Immediate Occupancy Performance Level. Although this level is a numerically intermediate level between Life Safety and Immediate Occupancy, the two performance objectives are essentially different from each other. The primary consideration for Immediate Occupancy is that the damage is limited in such a manner as to permit reoccupation of the building, with limited repair work occurring while the building is occupied. The primary consideration for Life Safety is that a margin of safety against collapse be maintained and that consideration for occupants to return to the building is a secondary impact to the Life Safety objective being achieved. The Damage Control Performance Level provides for a greater margin of safety against collapse than the Life Safety Performance Level would. The level might control damage in such a manner as to permit return to function more quickly than the Life Safety Performance Level, but not as quickly as the Immediate Occupancy Performance Level does.

**Life Safety:** “Life Safety” refers to the post-earthquake damage state in which significant damage to the structure has occurred but some margin against either partial or total structural collapse remains. Some structural elements and components are severely damaged, but this damage has not resulted in large falling debris hazards, either inside or outside the building. Injuries might occur during the earthquake; however, the overall risk of life-threatening injury from structural damage is expected to be low. It should be possible to repair the structure; however, for economic reasons, this repair might not be practical. Although the damaged structure is not an imminent collapse risk, it would be prudent to implement structural repairs or install temporary bracing before re-occupancy.

### ***Nonstructural Performance Objectives***

**Operational:** “Operational” refers to the performance level where most nonstructural systems required for normal use of the building are functional, although minor cleanup and repair of some items might be required. Achieving the Operational nonstructural performance level requires considerations of many elements beyond those that are normally within the sole province of the structural engineer’s responsibilities. For Operational nonstructural performance, in addition to ensuring that nonstructural components are properly mounted and braced within the structure, it is often necessary to provide emergency standby equipment to provide utility services from external sources that might be disrupted. It might also be necessary to perform seismic qualification testing to ensure that all necessary equipment will function during or after strong shaking.

**Position Retention:** “Position Retention” refers to the nonstructural condition of a building after an event where, presuming that the building is structurally safe, occupants can occupy the building safely, with some limitations: normal use might be impaired, some cleanup might be needed, and some inspection might be warranted. In general, building equipment is secured in place and might be able to function if the necessary utility service is available. However, some components might experience misalignments or internal damage and be inoperable. Power, water, natural gas, communications lines, and other utilities required for normal building use might not be available. Cladding, glazing, ceilings, and partitions might be damaged but would not present safety hazards or un-occupiable conditions. For this performance level, the risk of life-threatening injury caused by nonstructural damage is very low.

Detailed geotechnical and structural seismic evaluations should be conducted for existing wastewater system facilities to determine if their anticipated seismic performance will enable LOS goals to be achieved. To satisfy the target wastewater system restoration timeline, structures that must be operational soon after a major earthquake should be evaluated and if required, seismically retrofit to a more stringent structural and nonstructural performance level than those that are not required until later in the recovery phase. Table 5.2 provides the seismic retrofit criteria proposed for adoption by the City of Milwaukie for wastewater system facilities in terms of the structural and nonstructural performance objectives presented in ASCE 41. These performance objectives are for the Basic Safety Earthquake-1 for use with the Basic Performance Objective Equivalent to New Building Standards (BSE-1N). This BSE-1N seismic hazard level is consistent with that used to design new structures per the *Oregon Structural Specialty Code*. Table 5.2 also includes alternative (less stringent) retrofit performance objectives for system components that might not be required to be returned to service until 1-6 months or 6-12 months after the earthquake. For example, the City of Milwaukie may decide that one or more of the lift stations are not required to achieve short- or intermediate-term LOS goals and may elect to relax the restoration timeline goals for that particular wastewater system structure.

**Table 5.2 – Wastewater System Seismic Retrofit Performance Objectives**

Restoration Timeline	Retrofit Performance Objective <sup>a</sup>	
	Structural	Nonstructural
0-1 months	Immediate Occupancy	Operational
1-6 months	Immediate Occupancy	Position Retention <sup>b</sup>
6-12 months	Damage Control <sup>c</sup>	Position Retention <sup>b</sup>

<sup>a</sup> For the BSE-1N seismic hazard level as defined by ASCE 41-17.

<sup>b</sup> Assumes lead time for delivery and installation of damaged equipment falls within restoration timeline goals, otherwise equipment should be seismically certified per the requirements of the latest edition of ASCE 7.

<sup>c</sup> Assumes that the structural damage can be repaired within restoration timeline goals. For earthquake damage that may be especially difficult to repair within the target timeline, structure should be retrofitted to satisfy the Immediate Occupancy performance objective.

## 6.0 Limitations

The opinions and recommendations presented in this report were developed with the care commonly used as the state of practice of the profession. No other warranties are included, either expressed or implied, as to the professional advice included in this report. This report has been prepared for the City of Milwaukie to be used solely in its evaluation of the seismic performance of the wastewater system referenced. This report has not been prepared for use by other parties and may not contain sufficient information for purposes of other parties or uses.



## References

- ASCE. (2017a) ASCE 7-16, *Minimum Design Loads for Buildings and Other Structures*, American Society of Civil Engineers, Reston, VA.
- ASCE. (2017b) ASCE 41-17, *Seismic Evaluation and Retrofit of Existing Buildings*, American Society of Civil Engineers, Reston, VA.
- City and County of San Francisco Lifelines Council. (2014) *Lifelines Interdependency Study I Report*, San Francisco, CA.
- City Club. (2017) *Big Steps Before the Big One: How the Portland area can bounce back after a major earthquake*, City Club of Portland, Portland, OR.
- City of Milwaukie. (2020) *Council Resolution No. 8-2020 A Resolution of the City Council of the City of Milwaukie, Oregon Adopting Updates to the City's Addendum to the Clackamas County Multi-Jurisdictional Natural Hazards Mitigation Plan*, Milwaukie, OR.
- DOGAMI. (2010) *Cascadia*, Winter 2010, Department of Geology and Mineral Industries, Salem, OR.
- FEMA. (2015) *National Preparedness Goal*, Federal Emergency Management Agency, Washington D.C.
- Heubach, W. (2003) *Seismic Screening Checklist for Water and Wastewater Facilities*, Technical Council on Lifeline Earthquake Engineering Monograph No. 22, American Society of Civil Engineers, Reston, VA.
- NIST. (2015) *Community Resilience Planning Guide for Building and Infrastructure Systems*, NIST Special Publication 1190, National Institute of Standards and Technology, Gaithersburg, MD.
- Nojima, N. (2012) Restorations and System Interactions of Lifelines in the Great East Japan Earthquake Disaster, 2011, *Proceedings of the International Symposium on Engineering Lessons Learned from the 2011 Great East Japan Earthquake*, Tokyo, Japan
- OSSC. (2019) *Oregon Structural Specialty Code*, International Code Council, Country Club Hills, IL.
- OSSPAC. (2013) *The Oregon Resilience Plan, Reducing Risk and Improving Recovery for the Next Cascadia Earthquake and Tsunami*, Oregon Seismic Safety Policy Advisory Commission, Salem, OR.

REFERENCES

CITY OF MILWAUKIE WASTEWATER – SEISMIC LOS GOALS, PERFORMANCE OBJECTIVES, AND BACKBONE

---

SFPUC. (2014) *General Seismic Requirements for Design of New Facilities and Upgrade of Existing Facilities*, San Francisco Public Utilities Commission, San Francisco, CA.

SPUR. (2009) *Lifelines: Upgrading Infrastructure to Enhance San Francisco's Earthquake Resilience*, San Francisco Planning + Urban Research Association, San Francisco, CA.

# Appendix I. Lift Station Evaluation Technical Memorandum

**WASTEWATER SYSTEM MASTER PLAN  
ANALYSIS OF SYSTEM SEISMIC RESILIENCE**

**CITY OF MILWAUKIE PUBLIC WORKS DEPARTMENT  
MILWAUKIE, OREGON**

---

**Draft Technical Memorandum: Lift Station Seismic Evaluation**

September 15<sup>th</sup>, 2020  
SEFT Project Number: B19013.00







## Table of Contents

<b>List of Figures .....</b>	<b>ii</b>
<b>List of Tables.....</b>	<b>iv</b>
<b>1.0 Introduction and Background .....</b>	<b>1</b>
1.1 City of Milwaukie Wastewater System Description.....	1
1.2 Analysis of Wastewater System Seismic Resilience .....	1
<b>2.0 Evaluation Methodology and Seismic Performance Objectives .....</b>	<b>4</b>
2.1 Seismic Hazard .....	4
2.2 Seismic Performance Objectives .....	4
2.2.1 Structural Performance Objective .....	4
2.2.2 Nonstructural Performance Objective .....	4
2.3 Lift Station Evaluation Methodology .....	5
<b>3.0 Expected Seismic Structural and Nonstructural Performance .....</b>	<b>6</b>
3.1 Home and Monroe Lift Station (S3).....	6
3.3 Brookside Lift Station (S5) .....	21
<b>4.0 Next Steps.....</b>	<b>35</b>
<b>5.0 Limitations .....</b>	<b>36</b>
<b>References .....</b>	<b>37</b>



## List of Figures

Figure 1.1 – Locations of Lift Stations Evaluated .....	3
Figure 3.1 – Home and Monroe Lift Station (S3) Components .....	10
Figure 3.2 – Traffic-Rated Cover for Dry Well Access Hatch .....	11
Figure 3.3 – Emergency Generator Hookup on Electrical Cabinet .....	12
Figure 3.4 – Precast Concrete Wet Well Joint between Adjacent Stacked Riser Sections .....	12
Figure 3.5 – Precast Riser Joint Strengthening Concept .....	13
Figure 3.6 – Precast Riser Joint at Foundation Strengthening Concept .....	14
Figure 3.7 – Resin Injection Performance .....	15
Figure 3.8 – Vertical Pipe in Wet Well not Seismically Braced .....	15
Figure 3.9 – Valves and Pipes not Seismically Braced .....	16
Figure 3.10 – Pipes/Valves Potentially Lacking Adequate Gravity Support .....	16
Figure 3.11 – Pump Assembly not Braced to Structure Above Center of Gravity .....	17
Figure 3.12 – Missing Anchors at the Base of Pump Assembly.....	17
Figure 3.13 – Unrestrained Dehumidifier Unit.....	18
Figure 3.14 – Missing Anchors for SCADA Cabinet and Backup Battery.....	18
Figure 3.15 – SCADA Antenna Mast .....	19
Figure 3.16 – Electrical Cabinet.....	19
Figure 3.17 – Utility Pole Mounted Electrical Transformers .....	20
Figure 3.18 – Brookside Lift Station (S5) Components .....	26
Figure 3.19 – Electrical Cabinet.....	26
Figure 3.20 – Emergency Generator Hookup on Electrical Cabinet.....	27
Figure 3.21 – Washdown Water and Storage Enclosure .....	27
Figure 3.22 – Wet Well Access .....	28
Figure 3.23 – Flowmeter Vault Access Hatch .....	28
Figure 3.24 – Flowmeter Vault.....	29
Figure 3.25 – Precast Concrete Wet Well Joint between Adjacent Stacked Riser Sections .....	29
Figure 3.26 – Inadequate Blocking Between Diaphragm and Shear Wall.....	30

Figure 3.27 – Narrow Vertical Piers of Shear Wall..... 30  
Figure 3.28 – Solid Blocking Between Diaphragm and Shear Wall ..... 31  
Figure 3.29 – Suction Pipes Only Seismically Braced in One Direction..... 31  
Figure 3.30 – Air Can does not Appear to be Adequately Seismically Braced.... 32  
Figure 3.31 – Large Diameter Conduit does not Appear to be Adequately Braced  
..... 33  
Figure 3.32 – Unrestrained Backup Battery in SCADA Cabinet..... 33  
Figure 3.33 – Long Slender SCADA Antenna Mast ..... 34  
Figure 3.34 – PGE Electrical Transformer ..... 34

## List of Tables

Table 1.1 – Summary of Wastewater Lift Stations Evaluated .....	2
Table 1.2 – Evaluation Documents .....	2
Table 3.1 – Home and Monroe Lift Station Structural Evaluation and Preliminary Retrofit Recommendation Summary .....	7
Table 3.2 – Home and Monroe Lift Station Nonstructural Evaluation and Preliminary Retrofit Recommendation Summary .....	7
Table 3.3 – Brookside Lift Station Structural Evaluation and Preliminary Retrofit Recommendation Summary .....	22
Table 3.4 – Brookside Lift Station Nonstructural Evaluation and Preliminary Retrofit Recommendation Summary .....	24





## 1.0 Introduction and Background

### 1.1 City of Milwaukie Wastewater System Description

The City of Milwaukie wastewater system provides wastewater collection for City of Milwaukie residents and business, and small portions of the surrounding communities. The City service area is divided into seven collection basins with a total area of approximately 5 square miles. Larger diameter conveyance pipelines and wastewater treatment for the City of Milwaukie are primarily provided by Water Environment Services (WES). The City of Portland Bureau of Environmental Services (BES) provides conveyance and treatment services for wastewater collected in the Johnson Creek Basin at the northern end of the City service area.

The City owns and maintains approximately 80 miles of gravity pipelines and 1,700 manholes. These gravity pipelines range in diameter from 4 inches to 27 inches, with 81 percent of the gravity pipelines being 8 inches or less in diameter. The gravity system is augmented by five lift stations and approximately 3,500 lineal feet of force mains. The City wastewater system also includes two parallel inverted siphons (each constructed of 12-inch diameter ductile iron pipe) that cross Johnson Creek near Milwaukie Bay Park.

### 1.2 Analysis of Wastewater System Seismic Resilience

As part of the update process for the City of Milwaukie Wastewater Master Plan, the City of Milwaukie is conducting an analysis of the seismic resilience of the existing wastewater system. This project will evaluate the expected performance of selected components of the City wastewater system following a Magnitude 9.0 (M9.0) Cascadia Subduction Zone (CSZ) earthquake and identify preliminary recommendations for improvements that should be implemented to enable the City to more rapidly restore wastewater service after a major earthquake, to meet community social and economic needs. SEFT's scope of work for this wastewater system seismic resilience analysis includes:

1. Establishing Level of Service (LOS) goals for wastewater collection and conveyance following a M9.0 CSZ earthquake, based on supporting community social and economic needs;
2. Developing facility structural and nonstructural performance objectives to support achievement of LOS goals;
3. Working with the Water Systems Consulting (WSC) team to identify the wastewater collection and conveyance system backbone required to support short-term community social and economic needs;
4. Reviewing as-built construction drawings and any available retrofit drawings, calculations, and reports for two critical lift stations that are to be evaluated as part of this project;

5. Conducting a site visit to perform visual observation of the two critical lift stations;
6. Performing structural and nonstructural seismic evaluation of two critical lift stations using the Tier 1 checklist-based screening procedure of ASCE 41-17 *Seismic Evaluation and Retrofit of Existing Buildings* (ASCE, 2017) supplemented by TCLEE Monograph 22 *Seismic Screening Checklists for Water and Wastewater Facilities* (Heubach, 2003);
7. Developing preliminary recommendations to mitigate the structural and nonstructural deficiencies identified for the two critical lift stations; and
8. Coordinating with WSC to discuss potential consequence of failure of the two critical lift stations on collection and conveyance system operability.

This Technical Memorandum (TM) presents SEFT’s observations and recommendations related to scope items 4 through 7. The lift stations that have been evaluated by SEFT as part of this effort are summarized in Table 1.1 and the locations of these lift stations are shown in Figure 1.1. To complete this scope of work, SEFT utilized the TM on “Level of Service Goals and Performance Objectives”, completed as part of this project (SEFT, 2020) and the as-built drawings indicated in Table 1.2.

**Table 1.1 – Summary of Wastewater Lift Stations Evaluated**

Lift Station	Structure Type	Year of Original Construction
Home and Monroe (S3)	Wet Well - Precast Concrete Dry Well - Steel Shell	1973
Brookside (S5)	Wet Well - Precast Concrete Pump Building - Light-Frame Wood	1999

**Table 1.2 – Evaluation Documents**

Lift Station	As-Built Drawings
Home and Monroe (S3)	1 sheet (No. 129) by Stevens, Thompson & Runyan (assumed to be dated June 1973 based on drawing No. 128/131 for station S1)
Brookside (S5)	1 sheet by Murry, Smith, and Associates (dated March 1999), note that this drawing does not include the pump station building



**Figure 1.1 – Locations of Lift Stations Evaluated**

## 2.0 Evaluation Methodology and Seismic Performance Objectives

### 2.1 Seismic Hazard

This evaluation considered a single seismic hazard level associated with a M9.0 scenario earthquake originating on the Cascadia Subduction Zone (CSZ). As part of this project, McMillen Jacobs Associates (MJA) conducted a geotechnical seismic hazard assessment (MJA, 2020). In their report, MJA provided estimates of the spectral acceleration and permanent ground deformation (PGD) for liquefaction-induced settlement, liquefaction-induced lateral spreading, and earthquake-induced landslide associated with the M9.0 CSZ scenario earthquake. This geotechnical data was used as the basis for SEFT’s structural evaluation.

### 2.2 Seismic Performance Objectives

In the initial phase of this project, the WSC/SEFT team worked with the City of Milwaukie to establish proposed level of service (LOS) goals for the City of Milwaukie wastewater system following a major earthquake and associated structural and nonstructural performance objectives that are required to support achieving these LOS goals. The structural and nonstructural performance objectives used for this evaluation of wastewater system lift station for the M9.0 CSZ scenario earthquake are described in Sections 2.2.1 and 2.2.2.

#### 2.2.1 Structural Performance Objective

**Immediate Occupancy:** “Immediate Occupancy” refers to the post-earthquake damage state in which only very limited structural damage has occurred. The basic vertical- and lateral-force-resisting systems of the building retain almost all their pre-earthquake strength and stiffness. The risk of life-threatening injury from structural damage is very low, and although some minor structural repairs might be appropriate, these repairs would generally not be required before re-occupancy. Continued use of the building is not limited by its structural condition but might be limited by damage or disruption to nonstructural elements of the building, furnishings, or equipment and availability of external utility services.

#### 2.2.2 Nonstructural Performance Objective

**Operational:** “Operational” refers to the performance level where most nonstructural systems required for normal use of the building are functional, although minor cleanup and repair of some items might be required. Achieving the Operational nonstructural performance level requires considerations of many elements beyond those that are normally within the sole province of the structural engineer’s responsibilities. For Operational nonstructural performance, in addition to ensuring that nonstructural components are properly mounted and braced within the structure, it is often necessary to provide emergency standby equipment to provide utility services from external sources



that might be disrupted. It might also be necessary to perform qualification testing to ensure that all necessary equipment will function during or after strong shaking.

### **2.3 Lift Station Evaluation Methodology**

The seismic structural evaluation of lift stations was completed using the Tier 1 procedure of the standard by the American Society of Civil Engineers (ASCE), *Seismic Evaluation and Retrofit of Existing Buildings*, ASCE 41-17 (ASCE, 2017). This Tier 1 preliminary evaluation procedure uses a checklist-based approach to identify potential seismic structural deficiencies that have been commonly observed in past earthquakes. The Tier 1 procedure also uses quick-check calculations to evaluate potential deficiencies in the primary components of the seismic lateral-force-resisting system.

The seismic nonstructural evaluation of lift stations was completed using the nonstructural seismic evaluation checklists presented in ASCE 41-17, supplemented by the ASCE Technical Council on Lifeline Earthquake Engineering (TCLEE) Monograph No. 22, *Seismic Screening Checklists for Water and Wastewater Facilities* (Heubach, 2003). Similar to the ASCE 41 Tier 1 structural evaluation procedure, this checklist-based evaluation approach is used to identify potential seismic nonstructural deficiencies that have been commonly observed in past earthquakes.

## 3.0 Expected Seismic Structural and Nonstructural Performance

The expected structural and nonstructural seismic performance of two City of Milwaukee's lift stations has been evaluated for a M9.0 CSZ scenario earthquake. Sections 3.1 and 3.2 provide a short narrative description of the lift stations evaluated, followed by tables that summarize the potential seismic structural and nonstructural deficiencies identified by the seismic evaluation using the ASCE 41-17 Tier 1 and TCLEE Monograph No. 22 checklist-based procedures. These tables also include recommendations for further evaluation and/or preliminary retrofit recommendations. These sections also include selected photos taken during a site visit to the two lift stations that was conducted on August 19, 2020.

### 3.1 Home and Monroe Lift Station (S3)

The Home and Monroe (S3) Lift Station was originally constructed in 1973 with two 25 horsepower (hp) pumps providing the station with a firm capacity (with one pump out of service) of 400 gallons per minute (gpm). The lift station (see Figure 3.1) consists of a circular, segmented, precast concrete wet well and a separate below grade, circular steel shell dry well with a vertical access shaft. The access hatch to the dry well is located beneath a traffic-rated cover, as shown in Figure 3.2. The wet well is approximately 7 ft in diameter and 35 ft deep, while the dry well is approximately 8 ft in diameter and 8 ft high and contains the pumps, pump controls, and SCADA system. The main electrical cabinet for the station is located at the edge of the parking lot as shown in Figure 3.1. This electrical cabinet also includes a plug connection to power the pump station using a City-owned portable generator (see Figure 3.3).

Table 3.1 presents a summary of potential seismic structural deficiencies identified by this evaluation and preliminary retrofit recommendations to mitigate these potential deficiencies. Similarly, Table 3.2 presents a summary of potential seismic nonstructural deficiencies and preliminary retrofit recommendations. Based on the potential deficiencies identified by this evaluation, the Home and Monroe Lift Station (S3) is not currently expected to achieve Immediate Occupancy structural performance and is not currently expected to achieve Operational nonstructural performance for a M9.0 CSZ earthquake.

**Table 3.1 – Home and Monroe Lift Station Structural Evaluation and Preliminary Retrofit Recommendation Summary**

Component	Description
Potential Deficiencies	<ul style="list-style-type: none"> <li>• Relative movement between the wet well, dry well, and adjacent soil may damage pipes.</li> <li>• Riser joints of stacked precast wet well construction may separate and shift due to seismic lateral earth pressures on face of wet well. See Figure 3.4.</li> <li>• Sand, silt, or groundwater may infiltrate and leak into the wet well at the precast concrete construction joints.</li> </ul>
Preliminary Retrofit Recommendations	<ul style="list-style-type: none"> <li>• Provide flexible joints where piping enters and exists the wet well and dry well.</li> <li>• Install stainless steel bent plates to connect riser sections above and below the riser joints. Refer to Figure 3.5 for additional information. The number of riser joints to be strengthened with the stainless-steel bent plates should be determined based on further investigation as part of a future project.</li> <li>• Install stainless steel rolled angles to connect the bottom riser section to the wet well reinforced concrete mat foundation base. Refer to Figure 3.6 for additional information. Similarly, connect the top riser section to the wet well reinforced concrete lid.</li> <li>• Repair any leaking precast joints with a polyurethane resin injection or other similar method after an earthquake, as required. Refer to Figure 3.7 for additional information.</li> </ul>

**Table 3.2 – Home and Monroe Lift Station Nonstructural Evaluation and Preliminary Retrofit Recommendation Summary**

Component	Description
Potential Deficiencies	<ul style="list-style-type: none"> <li>• Per the original drawings, some piping, fittings, and valves associated with the lift station may be cast-iron, which is a brittle material that may crack when subjected to earthquake shaking-induced forces and/or ground deformation.</li> <li>• A vertical pipe in the wet well is not adequately braced or anchored to resist seismic forces. See Figure 3.8</li> <li>• Piping and valves in the dry well are not independently braced to resist seismic forces. See Figure 3.9.</li> </ul>

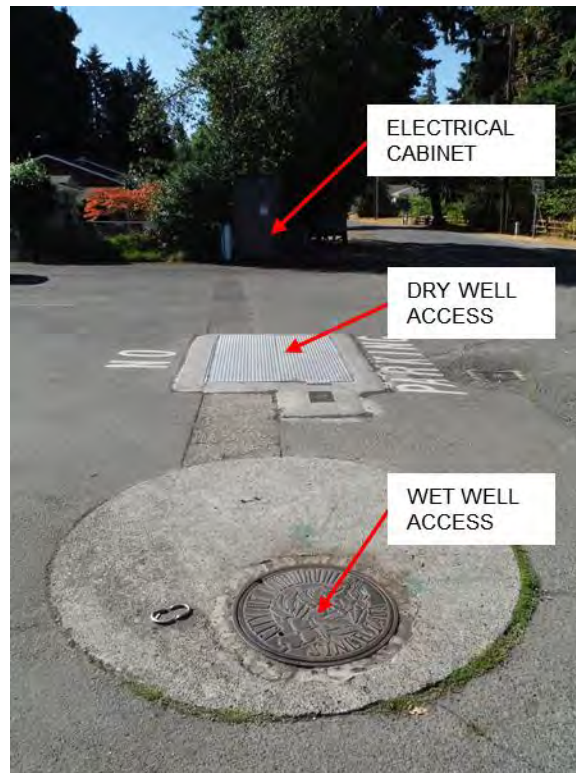
**Table 3.2 – Home and Monroe Lift Station Nonstructural Evaluation and Retrofit Recommendation Summary (cont.)**

Component	Description
Potential Deficiencies	<ul style="list-style-type: none"> <li>• The pump discharge pipe vertical support rod appears to be buckled, so it may not provide the intended gravity support and doesn't provide seismic bracing for the pipe. See Figure 3.10.</li> <li>• Pump assemblies are not braced to the structure above their center of gravity. See Figure 3.11.</li> <li>• The base of the east pump assembly appears to be missing an anchor bolt and may not be adequate to resist the expected seismic loads. See Figure 3.12.</li> <li>• The dry well dehumidifier unit is not adequately braced or anchored to resist seismic forces. See Figure 3.13.</li> <li>• The SCADA cabinet is anchored to its support bracket with two anchors near the front of the cabinet only. Without anchors near the back of the cabinet, it could potentially topple during an earthquake. See Figure 3.14.</li> <li>• The backup battery inside the SCADA cabinet is not restrained and could slide around inside the cabinet during an earthquake, damaging other components. See Figure 3.14.</li> <li>• Friction clips are used to attach the SCADA antenna mast to the electrical cabinet with steel strut, see Figure 3.15. However, friction clips are generally not considered to be reliable to resist earthquake-induced forces.</li> <li>• No anchors were visible between the electrical cabinet and its concrete support pad from the exterior of the cabinet. See Figure 3.16. Even if the cabinet is adequately anchored to the concrete pad, the size of the concrete pad may not be adequate to prevent the electrical cabinet from overturning during an earthquake.</li> <li>• The utility pole supporting the pole-mounted transformer providing power to the lift station is combustible and may not be designed for seismic forces generated by the transformer. See Figure 3.17.</li> </ul>
Preliminary Retrofit Recommendations	<ul style="list-style-type: none"> <li>• Verify that piping, fittings, and valve bodies are constructed of steel or ductile iron. Replace any components that are suspected to be cast iron.</li> <li>• Provide bracing/anchorage at approximately three points for the vertical pipe in the wet well.</li> </ul>

**Table 3.2 – Home and Monroe Lift Station Nonstructural Evaluation and Retrofit Recommendation Summary (cont.)**

Component	Description
Preliminary Retrofit Recommendations	<ul style="list-style-type: none"> <li>• Provide independent bracing for the piping and valves in the dry well or perform additional calculations to demonstrate that the piping, valves, and associated connections have adequate capacity to resist the expected seismic forces.</li> <li>• Provide adequate gravity support for the pump discharge pipe.</li> <li>• Perform additional analysis to evaluate the adequacy of the existing pump assembly and associated connections to resist the expected seismic forces, and provide bracing for the pump assembly above the center of gravity, as needed.</li> <li>• Add an anchor to the base of the east pump assembly at the location of the missing anchor.</li> <li>• Provide restraint for the dehumidifier unit (strap to support bracket, etc.).</li> <li>• Near the back of the SCADA cabinet, install two bolts between the cabinet and support bracket to provide adequate attachment for the cabinet.</li> <li>• Provide restraint in two perpendicular directions for the backup battery located in the SCADA cabinet.</li> <li>• Replace the existing friction clips with an appropriate attachment that provides a reliable connection between the antenna mast and the electrical cabinet.</li> <li>• Coordinate with an electrician for access to confirm if the electrical cabinet is anchored to the concrete support pad. Add anchors at the base of the electrical cabinet if anchors are not located inside the cabinet or are not adequate to resist the expected seismic forces. Also, evaluate the adequacy of the existing concrete support pad to resist overturning of the electrical cabinet and enlarge the existing pad, if necessary.</li> <li>• Coordinate with PGE to conduct further evaluation to validate seismic performance of pole-mounted transformer and utility pole. Potentially replace pole with one manufactured from a noncombustible material.</li> </ul>





**Figure 3.1 – Home and Monroe Lift Station (S3) Components**



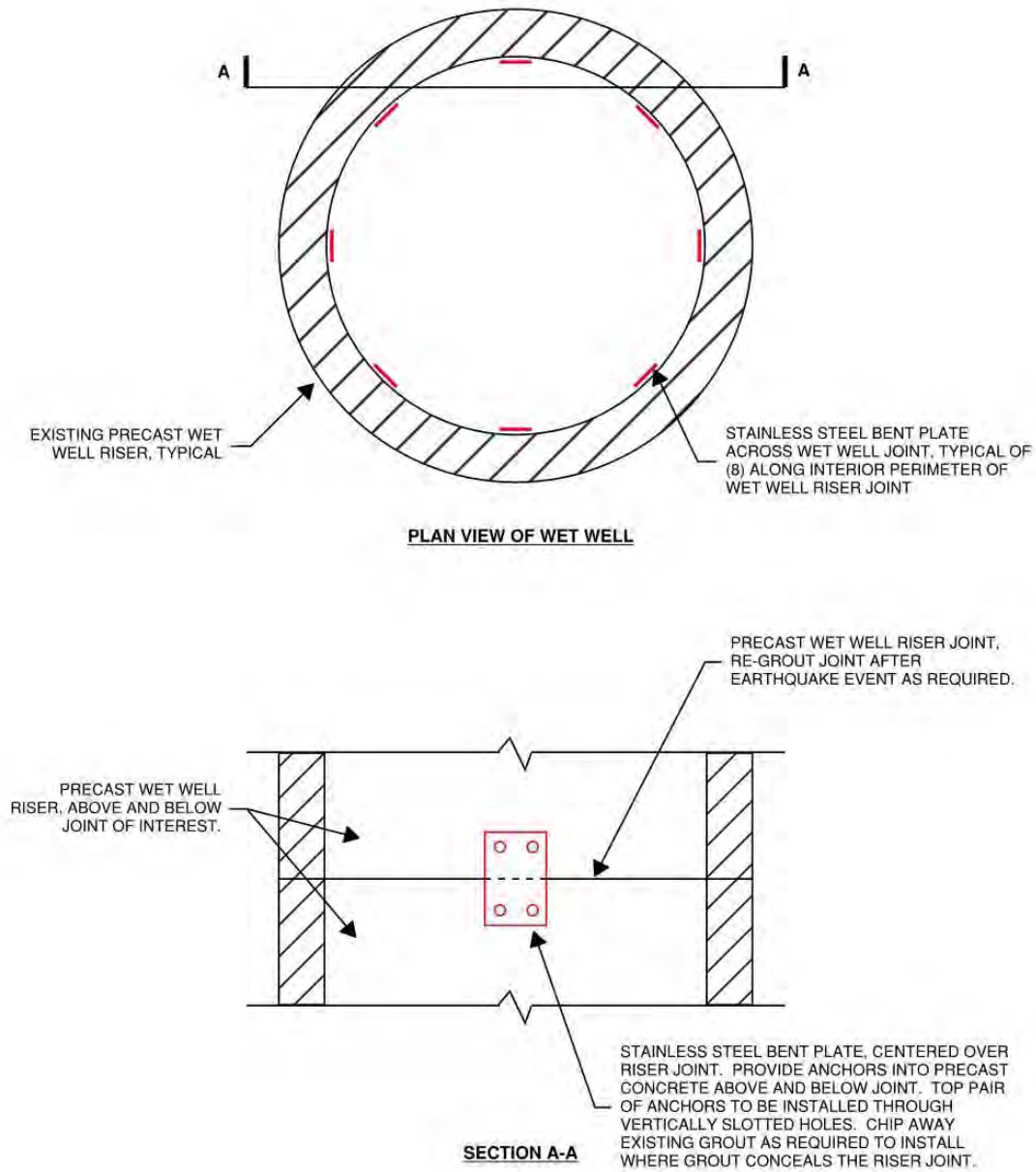
**Figure 3.2 – Traffic-Rated Cover for Dry Well Access Hatch**



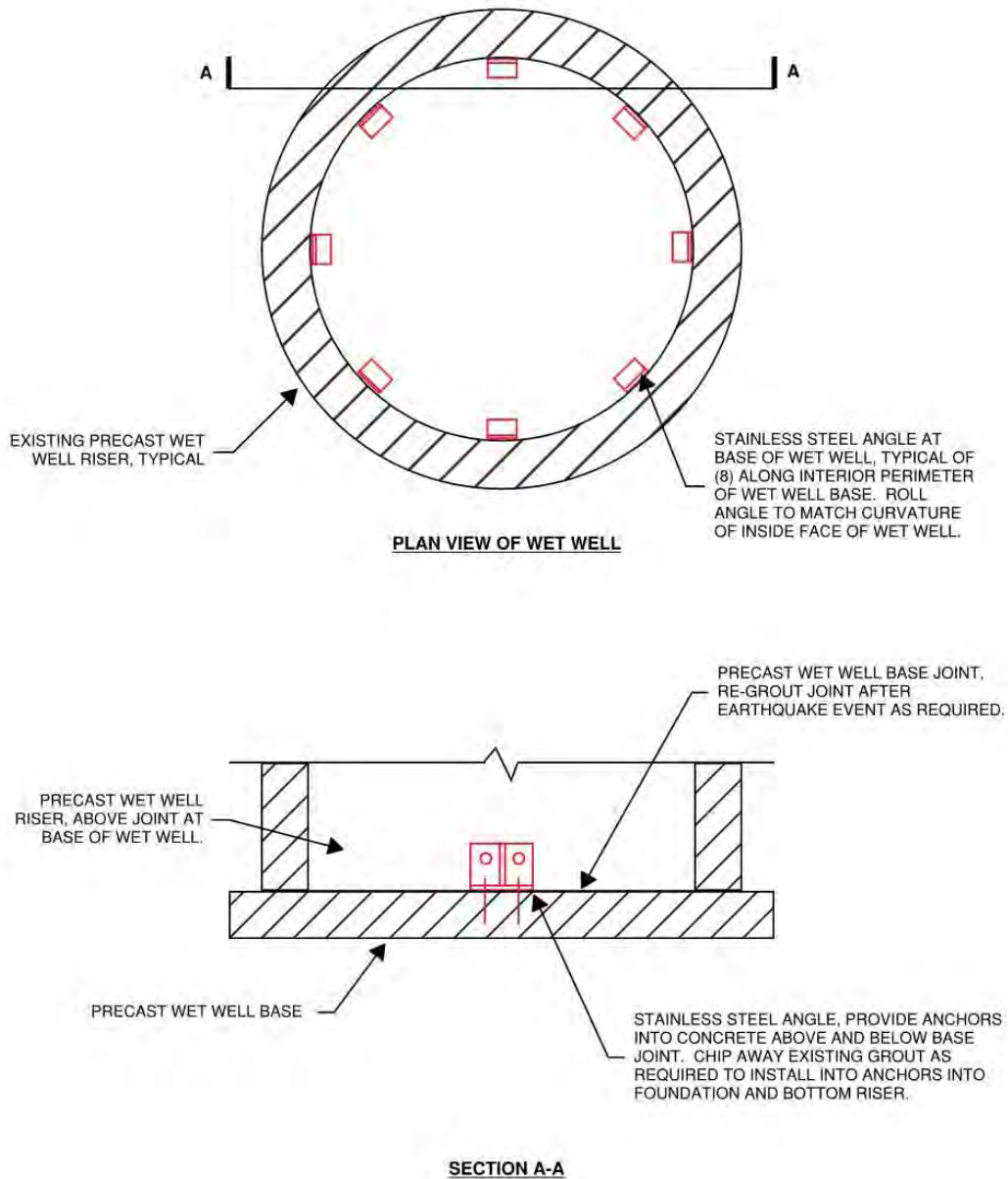
**Figure 3.3 – Emergency Generator Hookup on Electrical Cabinet**



**Figure 3.4 – Precast Concrete Wet Well Joint between Adjacent Stacked Riser Sections**



**Figure 3.5 – Precast Riser Joint Strengthening Concept**



**Figure 3.6 – Precast Riser Joint at Foundation Strengthening Concept**





**Figure 3.7 – Resin Injection Performance**  
(Source: Resiplast US Inc.)



**Figure 3.8 – Vertical Pipe in Wet Well not Seismically Braced**



**Figure 3.9 – Valves and Pipes not Seismically Braced**



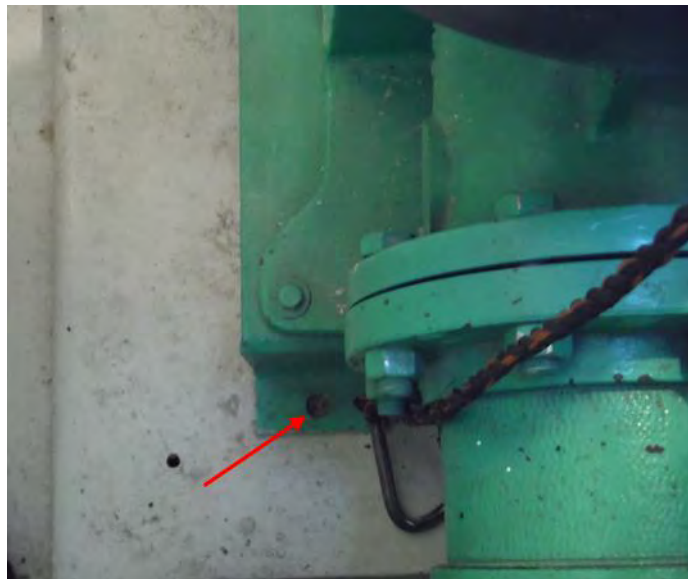
**Figure 3.10 – Pipes/Valves Potentially Lacking Adequate Gravity Support**



**Figure 3.11 – Pump Assembly not Braced to Structure Above Center of Gravity**



**(a) East Pump Assembly**



**(b) Missing Anchor**

**Figure 3.12 – Missing Anchors at the Base of Pump Assembly**





**Figure 3.13 – Unrestrained Dehumidifier Unit**



**Figure 3.14 – Missing Anchors for SCADA Cabinet and Backup Battery**



**(a) SCADA Antenna**



**(b) Antenna Mast Supported with Friction Clips**

**Figure 3.15 – SCADA Antenna Mast**



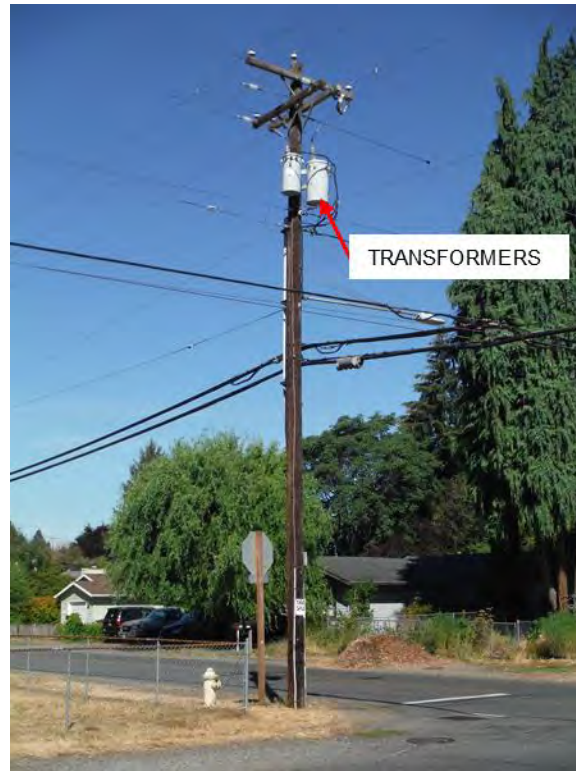
**(a) Overall View of Electrical Cabinet**



**(b) No Anchors between Cabinet and Concrete Pad Visible from Exterior of Cabinet**

**Figure 3.16 – Electrical Cabinet**





**Figure 3.17 – Utility Pole Mounted Electrical Transformers**

### 3.3 Brookside Lift Station (S5)

The Brookside (S5) Lift Station was originally constructed in 1999 with two 75 horsepower (hp) pumps providing the station with a firm capacity of 550 gpm. Pumps are located in an above grade, one-story light-frame wood structure (see Figure 3.18). The pump building is approximately 11 ft by 11 ft in plan with a height of 12 ft at the roof peak. The east and west end of the pump building both contain large access doors (9 ft by 6 ft) resulting in only approximately 30 in of shear wall remaining on either side of the doors. The north and south walls are mostly solid with a 3 ft wide window and an approximately 18 in square opening for ventilation. The pumps, motors, and the piping inside the pump building sit on a steel skid above a concrete base. Electrical equipment, pump controls, and the SCADA system are located in an exterior metal enclosure (see Figure 3.19). This exterior electrical cabinet also includes a plug connection to power the pump station using a portable generator (see Figure 3.20). Note that the City does not currently own a portable generator with adequate capacity to power this lift station. A wood-frame washdown water and storage enclosure (see Figure 3.21) contains a hose bib for washing down the wet well and miscellaneous storage. The lift station wet well is a circular, segmented, precast concrete structure (see Figure 3.22). The wet well is approximately 11 ft in diameter and 25 ft deep. Suction piping extends beneath the pump skid into the wet well and pump discharge piping enters back into the wet well from the pump skid to exit out of the west side of the wet well. A flowmeter vault is located in line with this pump discharge force main on the west side of the pump building, as shown in Figures 3.23 and 24.

Structural drawings were not available for the pump building and development of as-built drawings was beyond the scope of this study. No architectural finishes were removed to observe concealed construction details during the site visit. Potential structural deficiencies identified by this assessment have been based on field observations and general knowledge of typical construction practices during the era of original construction. Table 3.3 presents a summary of potential seismic structural deficiencies identified by this evaluation and preliminary retrofit recommendations to mitigate these potential deficiencies. Similarly, Table 3.4 presents a summary of potential seismic nonstructural deficiencies and preliminary retrofit recommendations. Based on the potential deficiencies identified by this evaluation, the Brookside Lift Station is not currently expected to achieve Immediate Occupancy structural performance and is not expected to achieve Operational nonstructural performance for a M9.0 CSZ earthquake. Additionally, based on the potential structural deficiencies identified by this evaluation, the Brookside Lift Station Pump Building is not expected to achieve Life Safety structural performance and potentially represents a safety hazard to City staff and contractors during and after a major earthquake.

**Table 3.3 – Brookside Lift Station Structural Evaluation and Preliminary Retrofit Recommendation Summary**

Component	Description
Potential Deficiencies	<ul style="list-style-type: none"> <li>• Per McMillen Jacobs Associate Report, moderate permanent ground deformation (PGD) is anticipated near the lift station: 0-2 inches of liquefaction induced settlement, 0-6 inches of lateral spreading. This level of PGD could potentially cause structural damage to the lift station wet well and pump building.</li> <li>• Relative movement between the wet well structure, flow meter vault, pump building, electrical/SCADA cabinet and adjacent soil may damage pipes and buried conduits (electrical and SCADA).</li> </ul> <p><b><u>Wet Well:</u></b></p> <ul style="list-style-type: none"> <li>• Riser joints of stacked precast wet well construction may separate and shift due to seismic lateral earth pressures on face of wet well. See Figure 3.25.</li> <li>• Sand, silt, or groundwater may infiltrate and leak into the wet well at the precast concrete construction joints.</li> </ul> <p><b><u>Pump Building:</u></b></p> <ul style="list-style-type: none"> <li>• The connection between the roof diaphragm and the north and south walls does not provide an adequate load path to transfer seismic forces from the roof to the walls. The blocking that is provided between roof framing members is perforated by long-slotted holes to provide roof ventilation. Also, the orientation of the blocking suggests that there is likely no connection between the blocking and stud wall top plate. See Figure 3.26.</li> <li>• Diaphragm chords (double 2x top plates) may not be continuous between end walls.</li> <li>• It is assumed that wood shear walls consist of structural sheathing over 2x framing. As the walls are covered by architectural finishes on both the exterior and interior sides of the walls, the actual construction could not be verified.</li> </ul>

**Table 3.3 – Brookside Lift Station Structural Evaluation and Preliminary Retrofit Recommendation Summary (cont.)**

Component	Description
Potential Deficiencies	<ul style="list-style-type: none"> <li>• The narrow vertical piers of the wood shear walls (on either side of the large doors on the east and west ends of the building) have a high aspect ratio (see Figure 3.27) and likely do not have adequate hold-downs between the vertical framing (chords of these wall piers) and the concrete foundation.</li> <li>• The adequacy of bolts between the shear wall sill plates and foundation could not be verified because they are not exposed to view.</li> </ul>
Preliminary Retrofit Recommendations	<ul style="list-style-type: none"> <li>• Collaborate with geotechnical engineer to mitigate horizontal and vertical permanent ground deformation by implementing ground improvements.</li> <li>• Provide flexible joints where piping and conduit enters and exists the wet well, flow meter vault, pump building, and electrical/SCADA cabinet.</li> </ul> <p><b><u>Wet Well:</u></b></p> <ul style="list-style-type: none"> <li>• Install stainless steel bent plates to connect riser sections above and below the riser joints. Refer to Figure 3.5 for additional information. The number of riser joints to be strengthened with the stainless-steel bent plates should be determined based on further investigation as part of a future project.</li> <li>• Install stainless steel rolled angles to connect the bottom riser section to the wet well reinforced concrete mat foundation base. Refer to Figure 3.6 for additional information. Similarly, connect the top riser section to the wet well reinforced concrete lid.</li> <li>• Repair any leaking precast joints with a polyurethane resin injection or other similar method after an earthquake, as required. Refer to Figure 3.7 for additional information.</li> </ul> <p><b><u>Pump Building:</u></b></p> <ul style="list-style-type: none"> <li>• Install shaped solid blocking between roof framing members to provide an adequate load path between the roof diaphragm and shear walls. See Figure 3.28.</li> </ul>

**Table 3.3 – Brookside Lift Station Structural Evaluation and Preliminary Retrofit Recommendation Summary (cont.)**

Component	Description
Preliminary Retrofit Recommendations	<ul style="list-style-type: none"> <li>• Confirm if existing diaphragm chords (wall top plates) are continuous. Install a continuous Simpson steel strap onto the outside face of the double 2x wall top plate of the perimeter walls, as required.</li> <li>• Locate as-built construction documents to confirm shear walls consist of structural sheathing and verify that nail spacing is adequate to resist the expected seismic forces. Otherwise, conduct a limited destructive investigation to verify details of original construction.</li> <li>• Locate as-built construction documents to confirm if narrow piers of shear walls have adequate hold-downs. Otherwise, conduct a limited destructive investigation to verify details of original construction.</li> <li>• Locate as-built construction documents to confirm if shear walls have adequate sill bolts. Otherwise, conduct a limited destructive investigation to verify details of original construction.</li> </ul>

**Table 3.4 – Brookside Lift Station Nonstructural Evaluation and Preliminary Retrofit Recommendation Summary**

Component	Description
Potential Deficiencies	<ul style="list-style-type: none"> <li>• The suction pipes in the wet well are not adequately braced to resist the expected seismic forces. See Figure 3.29.</li> <li>• The anchorage of the steel pump skid to the concrete slab below was concealed behind an architectural finish and could not be verified.</li> <li>• The air can that serves to eliminate water hammer when pumps shut off may not be adequately braced to resist the expected seismic forces. See Figure 3.30.</li> <li>• The large diameter electrical conduit that is suspended from the pump building ceiling may not be adequately braced to resist the expected seismic forces. See Figure 3.31.</li> </ul>



**Table 3.4 – Brookside Lift Station Nonstructural Evaluation and Preliminary Retrofit Recommendation Summary (cont.)**

Component	Description
Potential Deficiencies	<ul style="list-style-type: none"> <li>• The backup battery inside the SCADA cabinet is not restrained and could slide around inside the cabinet during an earthquake, damaging other components. See Figure 3.32.</li> <li>• The long, slender SCADA antenna mast may not have adequate capacity to resist the expected seismic forces. See Figure 3.33.</li> <li>• The PGE-owned electrical transformer does not appear to be anchored at the base. See Figure 3.34.</li> </ul>
Preliminary Retrofit Recommendations	<ul style="list-style-type: none"> <li>• Supplement or replace the existing rods that brace the suction pipes in the wet well to ensure that the pipes are adequately braced in two perpendicular directions.</li> <li>• Perform a limited destructive investigation to confirm if the steel pump skid is adequately anchored to the concrete slab below. If existing anchorage is not adequate, install additional anchors.</li> <li>• Perform additional analysis to evaluate the adequacy of the existing air can and associated connections to resist the expected seismic forces, and provide bracing for the air can, as required.</li> <li>• Provide bracing for the large diameter electrical conduit.</li> <li>• Provide restraint in two perpendicular directions for the backup battery located in the SCADA cabinet.</li> <li>• Perform additional calculations to demonstrate that the antenna mast and its connections have adequate capacity to resist the expected seismic forces, and replace long, slender SCADA antenna mast, as required.</li> <li>• Coordinate with PGE to verify if there is sufficient anchorage between the electrical transformer and concrete support slab, and provide appropriate anchorage as required.</li> </ul>



**Figure 3.18 – Brookside Lift Station (S5) Components**



**Figure 3.19 – Electrical Cabinet**



**Figure 3.20 – Emergency Generator Hookup on Electrical Cabinet**



**Figure 3.21 – Washdown Water and Storage Enclosure**

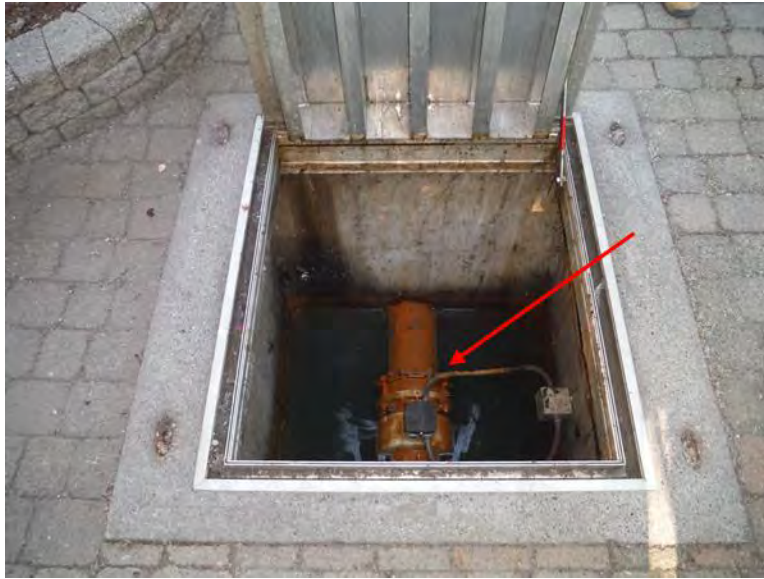




**Figure 3.22 – Wet Well Access**



**Figure 3.23 – Flowmeter Vault Access Hatch**



**Figure 3.24 – Flowmeter Vault**



**Figure 3.25 – Precast Concrete Wet Well Joint between Adjacent Stacked Riser Sections**



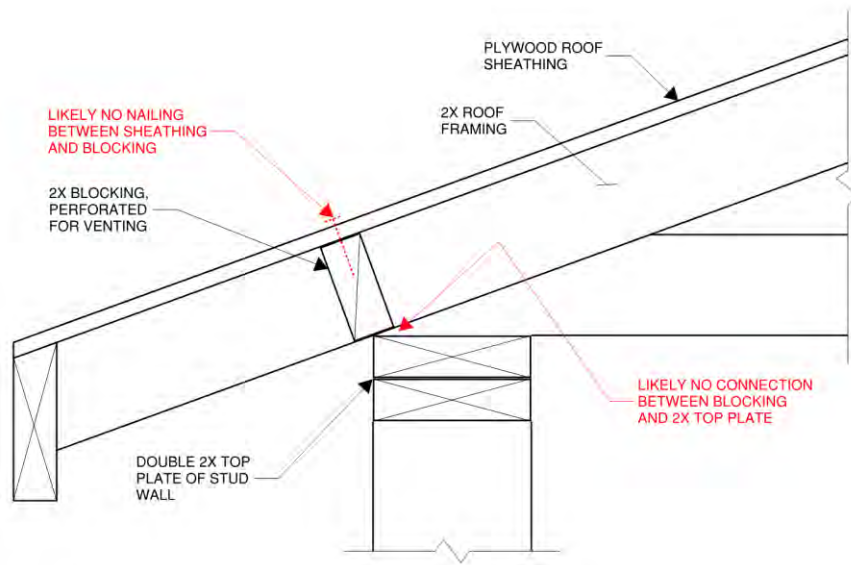
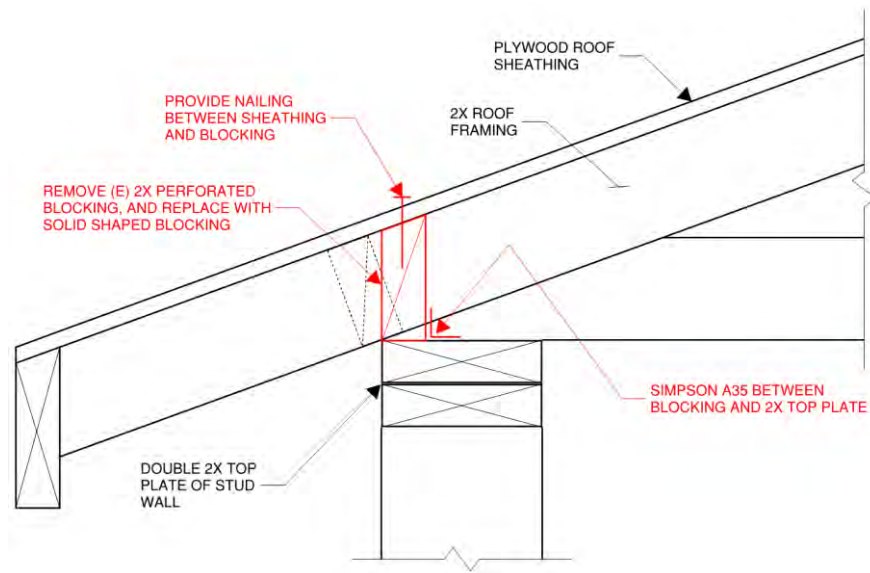


Figure 3.26 – Inadequate Blocking Between Diaphragm and Shear Wall



Figure 3.27 – Narrow Vertical Piers of Shear Wall



**Figure 3.28 – Solid Blocking Between Diaphragm and Shear Wall**



**Figure 3.29 – Suction Pipes Only Seismically Braced in One Direction**



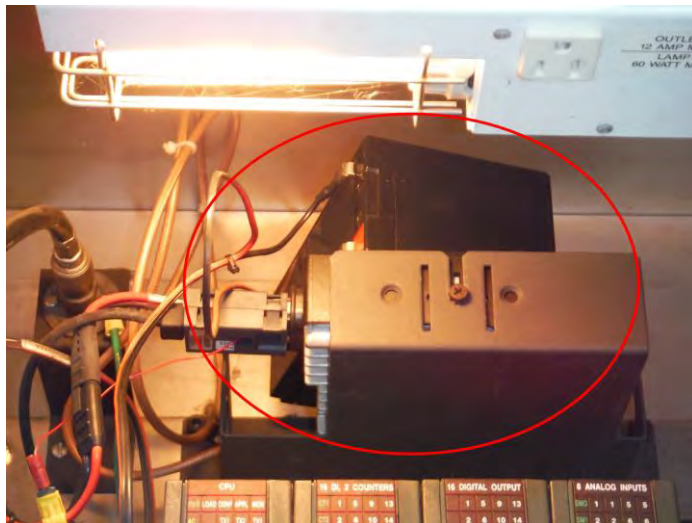
***Figure 3.30 – Air Can does not Appear to be Adequately Seismically Braced***



**Figure 3.31 – Large Diameter Conduit does not Appear to be Adequately Braced**



**(a) SCADA Cabinet**



**(b) Unrestrained Backup Battery**

**Figure 3.32 – Unrestrained Backup Battery in SCADA Cabinet**





**Figure 3.33 – Long Slender SCADA Antenna Mast**



**(a) Overall View of Electrical Transformer**



**(b) No Anchors between  
Transformer and Concrete Pad  
Visible from Exterior of  
Transformer**

**Figure 3.34 – PGE Electrical Transformer**



## 4.0 Next Steps

This technical memorandum summarizes the results of SEFT’s seismic structural and nonstructural evaluation of two lift stations (Home and Monroe, and Brookside). Based on the potential structural and nonstructural deficiencies observed, neither of the evaluated lift stations are expected to achieve either the Immediate Occupancy structural performance objective or Operational nonstructural performance objective for a M9.0 CSZ scenario earthquake. Implementing the seismic structural and nonstructural retrofit recommendations included in this technical memorandum will greatly improve the seismic resilience of the City’s wastewater system in the event of a major earthquake. As described in the TM on “Level of Service Goals and Performance Objectives”, completed as part of this project (SEFT, 2020), these backbone lift stations should be retrofit to achieve the Immediate Occupancy structural performance objective and Operation nonstructural performance objective for the BSE-1N seismic hazard level, as defined by ASCE 41-17.

As part of this wastewater master plan update project, limited structural/nonstructural seismic vulnerability assessments of two (2) lift stations were conducted to determine their estimated performance following a M9.0 CSZ earthquake. It is recommended that the City conduct a future seismic assessment of the remaining wastewater system structures. This will provide the City with a holistic view of the expected seismic performance of the wastewater system that can be leveraged in developing a comprehensive long-term plan for implementing wastewater system seismic resilience improvements.

In order to continue to advance the City’s wastewater system resilience planning process, we also recommend that a follow up study be conducted that includes consideration of dependency relationships. Planning for and addressing issues such as where the City will get fuel for trucks and generators, how emergency generators will be moved around to operate pump stations, how suppliers and contractors will be compensated, etc. will help improve resilience and speed the return to normalcy after a major disaster.

## 5.0 Limitations

The opinions and recommendations presented in this technical memorandum were developed with the care commonly used as the state of practice of the profession. No other warranties are included, either expressed or implied, as to the professional advice included in this technical memorandum. This technical memorandum has been prepared for the City of Milwaukie to be used solely in its evaluation of the seismic safety of the wastewater system components referenced. This technical memorandum has not been prepared for use by other parties and may not contain sufficient information for purposes of other parties or uses.

## References

ASCE. (2017) ASCE 41-17, *Seismic Evaluation and Retrofit of Existing Buildings*, American Society of Civil Engineers, Reston, VA.

Heubach, W. (2003) *Seismic Screening Checklist for Water and Wastewater Facilities*, Technical Council on Lifeline Earthquake Engineering Monograph No. 22, American Society of Civil Engineers, Reston, VA.

SEFT. (2020) *Wastewater System Master Plan Analysis of System Seismic Resilience, City of Milwaukie Public Works Department, Draft Technical Memorandum: Level of Service Goals, Performance Objectives, and Wastewater System Backbone*, Beaverton, OR.

McMillen Jacobs Associates MJA. (2020) *Seismic Geohazards Technical Memorandum, City of Milwaukie Wastewater System Master Plan Update*, Portland, OR.

# Appendix J. Detailed Cost Estimates

**Opinion of Probable Construction Cost**  
**Project CAP-1: Annual Manhole Survey**  
City of Milwaukee



Bid Item	Description	Quantity	Unit	Unit Price	Cost
1	Manhole Survey	1	LS	\$ 25,000.00	\$ 25,000.00

Project Costs \$ 25,000.00



**Opinion of Probable Construction Cost**

**Project CAP-2: Pipe Upgrades**

City of Milwaukie



Bid Item	Description	Quantity	Unit	Unit Price	Cost
1	Mobilization	1	LS	\$ 25,000.00	\$ 25,000.00
2	Insurance	1	LS	\$ 12,500.00	\$ 12,500.00
3	Survey	1	LS	\$ 4,000.00	\$ 4,000.00
4	Site Clearing	1	LS	\$ 4,000.00	\$ 4,000.00
5	Erosion and Sediment Control Plan	1	LS	\$ 2,500.00	\$ 2,500.00
6	Traffic Control	1	LS	\$ 19,000.00	\$ 19,000.00
7	Sawcut & Remove	832	SY	\$ 7.21	\$ 6,000.00
8	Hauling Pavement	92	LCY	\$ 10.81	\$ 1,000.00
9	Pavement Repair	832	SY	\$ 50.47	\$ 42,000.00
10	Shoring	20,608	SF Wall	\$ 1.02	\$ 21,000.00
11	Excavation-Trench	1,081	BCY	\$ 5.55	\$ 6,000.00
12	Pipe Bedding (sand import)	311	LCY	\$ 28.95	\$ 9,000.00
13	Bedding Compaction	311	ECY	\$ 3.22	\$ 1,000.00
14	Native Backfill & Compaction	770	ECY	\$ 3.89	\$ 3,000.00
15	Water Compaction	770	ECY	\$ 2.60	\$ 2,000.00
16	Hauling Excavation	1,298	BCY	\$ 4.62	\$ 6,000.00
17	10" PVC SDR 35	1,284	LF	\$ 140.19	\$ 180,000.00
18	4" PVC for Sewer Laterals	700	LF	\$ 50.00	\$ 35,000.00
19	Service Connection to 10" Gravity Main	28	EA	\$ 357.14	\$ 10,000.00
20	New Manholes	6	EA	\$ 15,000.00	\$ 90,000.00
21	Bypass Pumping	1	LS	\$ 6,000.00	\$ 6,000.00

<b>Subtotal</b>	\$ 485,000.00
<b>Construction Contingency (30%)</b>	\$ 145,000.00
<b>Construction Total</b>	\$ 630,000.00
<b>Project Development &amp; Implementation (30%)</b>	\$ 189,000.00
<b>Project Costs</b>	\$ 819,000.00

**Opinion of Probable Construction Cost**  
**Project CAP-3: Flow Monitoring (Per Deployment)**  
 City of Milwaukie



Bid Item	Description	Quantity	Unit	Unit Price	Cost
1	Planning, Mobilization, Installation, Programming, Calibration	6	EA	\$ 1,666.67	\$ 10,000.00
2	Monthly Monitoring, QA/AC, and Data Acquisition	6	EA	\$ 1,333.33	\$ 8,000.00
3	Station Decommissioning and Final Flow Data	6	EA	\$ 666.67	\$ 4,000.00
4	Rain Gauge - Fixed Cost (EA)	6	EA	\$ 166.67	\$ 1,000.00
5	Rain Gauge monitoring and reporting (monthly)	6	EA	\$ 166.67	\$ 1,000.00

<b>Subtotal</b>	\$ 24,000.00
<b>Project Development &amp; Implementation (30%)</b>	\$ 7,000.00
<b>Project Costs</b>	\$ 31,000.00

CAP-4



**HARVEY STREET IMPROVEMENTS**

*32nd Avenue to 42nd Avenue, 33rd Avenue and 36th Avenue*

**Harvey Street SAFE/SSMP:** Fill in sidewalk gaps on both sides of street, replace portions of existing sidewalk, and remove ADA barriers. Reconstruct roadway surface, install traffic calming improvements, and improve bicycle connections.

**Water System Improvements:** Projects will include replacement of existing valves and reconnection of existing water services.

*Harvey Street:* Replace approximately 2,500 feet and upsize various sections of 4-inch and 6-inch cast iron water main to 8-inch ductile iron pipe to improve fire flows and water quality in the neighborhood.

*33rd Avenue:* Replace approximately 470 feet and upsize the existing 4-inch water main to 8-inch ductile iron pipe to improve fire flows in the neighborhood. The new main will connect to the 12-inch water main on Harvey Street.

*36th Avenue:* Replace approximately 600 feet and upsize the existing 4-inch and 6-inch water main to 8-inch ductile iron pipe to improve fire flows in the neighborhood and may include the proper abandonment of the 2-inch line on Sherry Lane. The new main will connect to the 12-inch main on Harvey Street.

**Stormwater System Improvements:** Roadway reconstruction triggers stormwater treatments which will include 4,000 sq ft of vegetated stormwater planters within the right-of-way.

**Wastewater System Improvements:** Provide pipe stub out to right-of-way to Willamette Townhouse Apartments.

**Operating Budget Impact:** *This project will potentially increase ongoing operational needs due to the addition of new infrastructure. However, pipe repairs and replacements will reduce operating expenditures due to the reduction of maintenance issues.*

**Source:** BPAP, SSMP, RTP, TSP, WMP

**Submitted by:** Engineering, Public Works

	FY 2021	FY 2022	FY 2023	FY 2024	FY 2025	FY 2026	TOTAL
<b>Capital Cost:</b>							
Planning, Engineering, Design	\$80,000						\$80,000
Land/ROW Acquisition							n/a
Construction		\$2,868,000					\$2,868,000
<b>TOTAL EST. CAPITAL COST</b>	<b>\$80,000</b>	<b>\$2,868,000</b>					<b>\$2,948,000</b>
<b>Funding Source:</b>							
SAFE	\$30,000	\$503,000					\$553,000
SSMP	\$50,000	\$700,000					\$750,000
Stormwater		\$366,000					\$366,000
Wastewater		\$5,000					\$5,000
Water		\$983,000					\$983,000
<b>TOTAL FUNDING</b>	<b>\$80,000</b>	<b>\$2,868,000</b>					<b>\$2,948,000</b>

**Opinion of Probable Construction Cost**

**Project C-1: Pipeline Rehabilitation and Replacement**

City of Milwaukee



Bid Item	Description	Quantity	Unit	Unit Price	Cost
1	Mobilization	1	LS	\$ 205,000.00	\$ 205,000.00
2	Insurance	1	LS	\$ 100,000.00	\$ 100,000.00
3	Survey	1	LS	\$ 42,000.00	\$ 42,000.00
4	Site Clearing	1	LS	\$ 17,000.00	\$ 17,000.00
5	Erosion and Sediment Control Plan	1	LS	\$ 22,000.00	\$ 22,000.00
6	Traffic Control	1	LS	\$ 133,000.00	\$ 133,000.00
7	6" Cured in Place Pipe	148	LF	\$ 47.30	\$ 7,000.00
8	8" Cured in Place Pipe	11,046	LF	\$ 48.98	\$ 541,000.00
9	10" Cured in Place Pipe	2,950	LF	\$ 53.90	\$ 159,000.00
10	12" Cured in Place Pipe	15,621	LF	\$ 59.98	\$ 937,000.00
11	15" Cured in Place Pipe	652	LF	\$ 98.16	\$ 64,000.00
12	16" Cured in Place Pipe	232	LF	\$ 99.14	\$ 23,000.00
13	18" Cured in Place Pipe	390	LF	\$ 135.90	\$ 53,000.00
14	Reinstate Sewer Service Lateral	538	EA	\$ 100.37	\$ 54,000.00
15	Point Repair - 8 ft Segment - 6"/8" Pipe	3	EA	\$ 12,000.00	\$ 36,000.00
16	Point Repair - 8 ft Segment - 10"/12" Pipe	5	EA	\$ 21,000.00	\$ 105,000.00
17	Cleaning, Testing, and Post CCTV	31,073	LF	\$ 1.90	\$ 59,000.00
18	Manhole Repairs	18	EA	\$ 3,277.78	\$ 59,000.00
19	Sawcut & Remove	3,497	SY	\$ 6.86	\$ 24,000.00
20	Hauling Pavement	389	LCY	\$ 7.72	\$ 3,000.00
21	Pavement Repair	3,497	SY	\$ 50.04	\$ 175,000.00
22	Shoring	112,627	SF Wall	\$ 1.00	\$ 113,000.00
23	Excavation - Trench	6,854	BCY	\$ 5.98	\$ 41,000.00
24	Pipe Bedding (sand import)	1,410	LCY	\$ 29.80	\$ 42,000.00
25	Bedding Compaction	1,410	ECY	\$ 2.84	\$ 4,000.00
26	Native Backfill & Compaction	5,444	ECY	\$ 4.04	\$ 22,000.00
27	Water Compaction	6,874	ECY	\$ 2.47	\$ 17,000.00
28	Hauling Excavation	8,224	BCY	\$ 4.50	\$ 37,000.00
29	Abandon Existing Main in Place - 8" Pipe	800	LF	\$ 2.50	\$ 2,000.00
30	Abandon Existing Main in Place - 10" Pipe	173	LF	\$ 5.78	\$ 1,000.00
31	Abandon Existing Main in Place - 12" Pipe	827	LF	\$ 3.63	\$ 3,000.00
32	Abandon Existing Main in Place - 18" Pipe	2,607	LF	\$ 4.99	\$ 13,000.00
33	Abandon Existing Main in Place - 20" Pipe	436	LF	\$ 6.88	\$ 3,000.00
34	Abandon Existing Main in Place - 24" Pipe	160	LF	\$ 6.25	\$ 1,000.00
35	8" HDPE	800	LF	\$ 42.50	\$ 34,000.00
36	10" HDPE	173	LF	\$ 57.80	\$ 10,000.00
37	12" HDPE	827	LF	\$ 83.43	\$ 69,000.00
38	18" HDPE	2,607	LF	\$ 110.08	\$ 287,000.00
39	20" HDPE	436	LF	\$ 149.08	\$ 65,000.00
40	24" HDPE	160	LF	\$ 181.25	\$ 29,000.00
41	Bypass Pumping - 8"	1	LS	\$ 3,000.00	\$ 3,000.00
42	Bypass Pumping - 10"	1	LS	\$ 1,000.00	\$ 1,000.00
43	Bypass Pumping - 12"	1	LS	\$ 6,000.00	\$ 6,000.00
44	Bypass Pumping - 18"	1	LS	\$ 34,000.00	\$ 34,000.00
45	Bypass Pumping - 21"	1	LS	\$ 6,000.00	\$ 6,000.00
46	Bypass Pumping - 24"	1	LS	\$ 3,000.00	\$ 3,000.00
47	Rehabilitate Manhole	5	EA	\$ 4,200.00	\$ 21,000.00
48	4" PVC for Sewer Laterals	402	LF	\$ 49.75	\$ 20,000.00
49	Service Connections to 8" Gravity Main	3	EA	\$ 500.00	\$ 1,500.00
50	Service Connections to 10" Gravity Main	1	EA	\$ 500.00	\$ 500.00
51	Service Connections to 12" Gravity Main	5	EA	\$ 400.00	\$ 2,000.00
52	Service Connections to 18" Gravity Main	7	EA	\$ 1,000.00	\$ 7,000.00

Subtotal	\$ 3,716,000.00
Construction Contingency (30%)	\$ 1,115,000.00
Construction Total	\$ 4,831,000.00
Project Development & Implementation (30%)	\$ 1,449,000.00
Project Costs	\$ 6,280,000.00
Cost Timeline (Years)	10
Average Cost Per Year	\$ 628,000.00

Cost Breakdown Within the CIP

Years	Annual Cost	Total Cost
1-4 (FY23-FY26)	\$381,000	\$1,524,000
5-10 (FY27-FY32)	\$792,000	\$4,752,000
11 - 19 (FY33 -FY41)	\$628,000	\$5,652,000
Total		\$11,928,000

**Opinion of Probable Construction Cost**  
**Project C2 - Pump Station Condition Assessment**  
 City of Milwaukie



Bid Item	Description	Quantity	Unit	Unit Price	Cost
1	S1 Condition Assessment	1	LS	\$ 5,750.00	\$ 5,750.00
2	S2 Condition Assessment	1	LS	\$ 5,750.00	\$ 5,750.00
3	S5 Condition Assessment	1	LS	\$ 5,750.00	\$ 5,750.00
4	S6 Condition Assessment	1	LS	\$ 5,750.00	\$ 5,750.00

<b>Subtotal</b>	\$ 23,000.00
<b>Project Development &amp; Implementation (30%)</b>	\$ 7,000.00
<b>Project Costs</b>	\$ 30,000.00



**Opinion of Probable Construction Cost**  
**Projects C3 through C-7, R-1 through R-3**  
 City of Milwaukie



Bid Item	Description	Quantity	Unit	Unit Price	Cost
1	S1 Improvements	1	LS	\$ 621,000.00	\$ 621,000.00
2	S2 Improvements	1	LS	\$ 775,000.00	\$ 775,000.00
3	S3 Improvements	1	LS	\$ 948,000.00	\$ 948,000.00
4	S5 Improvements	1	LS	\$ 1,561,000.00	\$ 1,561,000.00
5	S6 Improvements	1	LS	\$ 239,000.00	\$ 239,000.00
6	S1 Seismic Improvements	1	LS	\$ 32,000.00	\$ 32,000.00
7	S3 Seismic Improvements	1	LS	\$ 32,000.00	\$ 32,000.00
8	S5 Seismic Improvements	1	LS	\$ 52,000.00	\$ 52,000.00

<b>Project Costs</b>	\$ 4,260,000.00
<b>Project Timeline (Years)</b>	20
<b>Cost Per Year</b>	\$ 213,000.00

Notes:

- 1 Project costs include all construction and planning contingencies

**Opinion of Probable Construction Cost**  
**Project C8 - Johnson Creek Siphon Inspection**  
 City of Milwaukie



Bid Item	Description	Quantity	Unit	Unit Price	Cost
1	Inspection	2,000	LF	\$ 29.50	\$ 59,000.00

<b>Subtotal</b>	\$ 59,000.00
<b>Construction Contingency (30%)</b>	\$ 18,000.00
<b>Construction Total</b>	\$ 77,000.00
<b>Project Development &amp; Implementation (30%)</b>	\$ 23,000.00
<b>Project Costs</b>	\$ 100,000.00

PROJECT C-9



**WAVERLY HEIGHTS SEWER SYSTEM RECONFIGURATION**

Replace and reconfigure the aging wastewater system within the Waverly Heights area of northwest Milwaukee. The 2010 Wastewater System Master Plan proposes five design alternatives. Design for the appropriate solution for the neighborhood’s sewer system will occur in Fiscal Year 2023 and construction will follow in Fiscal Years 2024 and 2025.

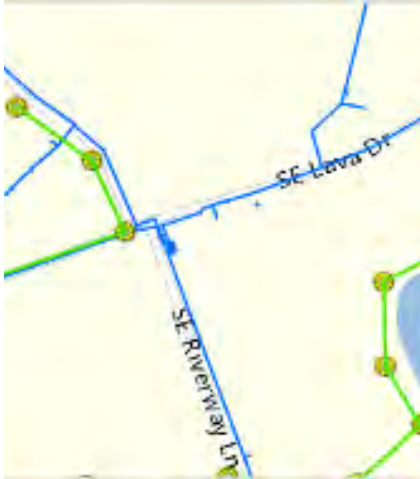
It is proposed to complete this project through an alternative delivery method. This would allow the project to evaluate the use of multiple construction methods and value engineer options with contractor and design team which will be managed by city staff.

**Operating Budget Impact:** This project will not increase operating expenditures. It will help solve a major maintenance issue for the city and will reduce infiltration and inflow into the system.

**Source:** Wastewater Master Plan **Submitted by:** Public Works

	FY 2021	FY 2022	FY 2023	FY 2024	FY 2025	FY 2026	TOTAL
<b>Funding Source:</b>							
Wastewater			\$400,000	\$1,394,000	\$1,294,000		\$3,088,000
Wastewater SDC				\$169,000	\$147,000		\$316,000
<b>TOTAL FUNDING</b>			<b>\$400,000</b>	<b>\$1,563,000</b>	<b>\$1,441,000</b>		<b>\$3,404,000</b>

PROJECT C-10



**WAVERLY SOUTH IMPROVEMENTS**

*Lave Drive, Waverly Court, Riverway Lane*

**Lava Drive & Waverly Court SAFE/SSMP:** Fill in sidewalk gaps on both sides of the streets, replace portions of sidewalk, overlay surface on Lava Drive and reconstruct asphalt surface on Waverly Court, from 17th Avenue to Highlands Apartments Entrance.

**Riverway Lane Sewer Repair:** Fix heavy root intrusion in portions of the mainline. Mainline is a trunk line and collects from the Waverly area, and a manhole installation at 153 feet would allow access to a private sewer mainline for 3 homes. Project could use a pipeburst method and would include reconnection of services. MH 1087 – 1086: Length 220.6'; Upstream depth 10'; Downstream depth 11.5'; Number of services 2, Diameter 10'

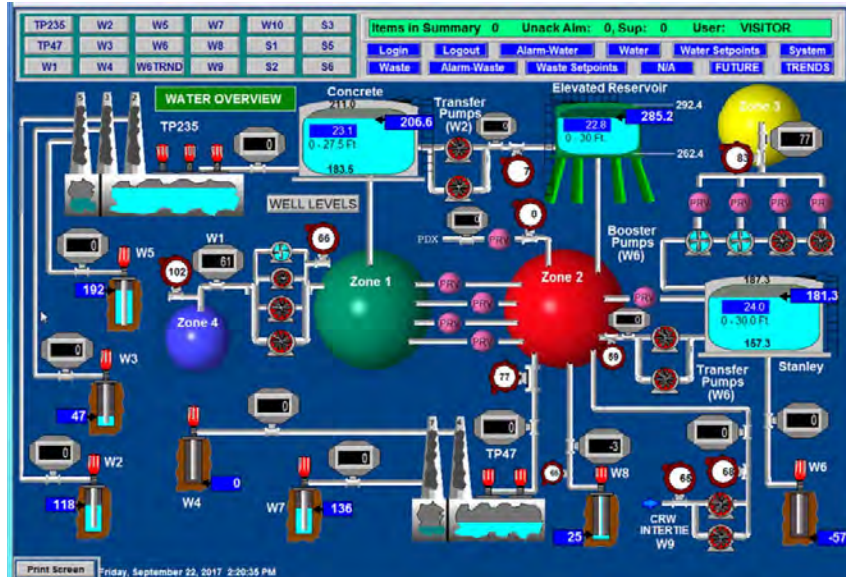
**Riverway Lane Water Line Replacement:** Replace the existing 2-inch water line with a 6-inch ductile iron pipe water main to address hydraulic, structural, and water quality issues. This project may require an additional easement and will include reconnection of services and hydrants.

**Operating Budget Impact:** *The paving projects could potentially increase ongoing operational needs due to the addition of new infrastructure. However, the pipe replacements would decrease ongoing operational needs by restoring infrastructure to good condition.*

**Source:** WWMP, WMP

**Submitted by:** Engineering, Public Works

	FY 2021	FY 2022	FY 2023	FY 2024	FY 2025	FY 2026	TOTAL
<b>Capital Cost:</b>							
Planning, Engineering, Design		\$40,000					\$40,000
Land/ROW Acquisition							n/a
Construction			\$786,000				\$786,000
<b>TOTAL EST. CAPITAL COST</b>		<b>\$40,000</b>	<b>\$786,000</b>				<b>\$826,000</b>
<b>Funding Source:</b>							
SAFE		\$20,000	\$278,000				\$298,000
SSMP		\$20,000	\$302,000				\$322,000
Wastewater			\$91,000				\$91,000
Water			\$115,000				\$115,000
<b>TOTAL FUNDING</b>		<b>\$40,000</b>	<b>\$786,000</b>				<b>\$826,000</b>



## SCADA DESIGN & CONSTRUCTION

Supervisory Control and Data Acquisition (SCADA) is a system for remote monitoring and control. The last system installed for the City of Milwaukie was in 1998 but advances in technology and communication have made the city's current system obsolete and difficult to maintain. A goal for an updated system is to maintain the highest possible system security and system integrity while improving site security, control capabilities, data acquisition, and a simplified user interface. The cost will be shared between the Water and Wastewater funds.

### THE KEY ELEMENTS OF THE PROJECT ARE:

**Modernization:** Implementation of modern technology will minimize support requirements, system administration, and improve maintenance support.

**Best Practices:** Undertaking this upgrade provides the utility with other improvements that can be realized by incorporating best practices for control industry system implementation.

**Cybersecurity:** Ensures security is implemented as part of any SCADA system addition or modification.

Project design began in Spring 2020. Estimated project costs are:

- Design and integration: \$470,000
- Field automation construction: \$400,000
- Communications infrastructure: \$240,000
- Network architecture infrastructure: \$200,000
- Construction management: \$175,000

**Operating Budget Impact:** This project would decrease ongoing operational needs by restoring infrastructure to good condition.

**Source:** Public Works Maintenance **Submitted by:** Public Works

	FY 2021	FY 2022	FY 2023	FY 2024	FY 2025	FY 2026	TOTAL
<b>Capital Cost:</b>							
Planning, Engineering, Design	\$470,000						\$470,000
Land/ROW Acquisition							n/a
Construction	\$995,000	\$105,000					\$1,100,000
<b>TOTAL EST. CAPITAL COST</b>	<b>\$1,570,000</b>	<b>\$105,000</b>					<b>\$1,570,000</b>
<b>Funding Source:</b>							
Water	\$935,000						\$935,000
Wastewater	\$530,000	\$105,000					\$635,000
<b>TOTAL FUNDING</b>	<b>\$1,570,000</b>	<b>\$105,000</b>					<b>\$1,570,000</b>



PROJECT C-12



**ARDENWALD NORTH IMPROVEMENTS**

**SAFE & SSMP IMPROVEMENTS**

*28th Avenue & Van Water Street:* Fill in sidewalk gaps, replace portions of existing sidewalk, and reconstruct the asphalt surface with new overlay from the Springwater Corridor to 32nd Avenue.

*32nd Avenue:* Replace portions of existing sidewalk, remove barriers, and reconstruct asphalt surface with new overlay from Van Water Street to Roswell Street.

*Roswell Street:* Fill in sidewalk gaps, remove ADA barriers, and reconstruct asphalt surface from 32nd Avenue to Rockvorst Street.

**Stormwater Improvements:** Replace stormwater system with 12-inch PVC, install 5 G2 catch basins, and 2 manholes at each mid-block for improved access. Van Water Street (29th Avenue to 31st Avenue).

**Water System Improvements:** Replace and upsize existing cast iron 4-inch water main to 8-inch ductile iron pipe to improve fire flows in the neighborhood. New mains will connect to existing 8-inch water main. The project will include the replacement of existing valves, and reconnection of existing water services and hydrants along the length of the pipes, 29th Avenue, 30th Avenue, 31st Avenue (Roswell Street to Van Water Street), and Roswell Street (29th Avenue to 32nd Avenue).

**Wastewater System Improvements:** Address multiple bellies and root intrusion to reduce debris buildup. Additional manholes will be installed where needed to ease maintenance issues. Full line replacement is recommended, and will include reconnection of services along the replaced line.

*28th Avenue (Roswell Street to Van Water Street):*

28th Avenue: MH 1212 – 1211: Length 415', Upstream depth 15', Downstream depth 11.4', Number of services 14, Diameter 8"

*Van Water Street:*

MH 1213 – 1212: Length 411.4', Upstream depth 16', Downstream depth 15', Number of services 14, Diameter 8"

*29th Avenue (South of Van Water Street):*

MH 1222 – 1220: Length 341.2', Upstream depth 12', Downstream depth 8.25', Number of services 10, Diameter 8"

*31st Avenue (North of Roswell Street):*

MH 1910 – 1200: Length 374.3', Upstream depth 11.5', Downstream depth 15.2', Number of services 13, Diameter 8"

**Operating Budget Impact:** *The paving projects could potentially increase ongoing operational needs due to the addition of new infrastructure. However, the pipe replacements would decrease ongoing operational needs by restoring infrastructure to good condition.*

**Source:** SAFE, SSMP, WMP, Public Works Maintenance

**Submitted by:** Engineering, Public Works

	FY 2021	FY 2022	FY 2023	FY 2024	FY 2025	FY 2026	TOTAL
<b>Capital Cost:</b>							
Planning, Engineering, Design	\$80,000						\$80,000
Land/ROW Acquisition							n/a
Construction		\$2,472,000					\$2,472,000
<b>TOTAL EST. CAPITAL COST</b>	<b>\$80,000</b>	<b>\$2,472,000</b>					<b>\$2,552,000</b>
<b>Funding Source:</b>							
SAFE	\$30,000	\$669,000					\$699,000
SSMP		\$313,000					\$313,000
Stormwater		\$160,000					\$160,000
Wastewater		\$476,000					\$476,000
Water	\$50,000	\$854,000					\$904,000
<b>TOTAL FUNDING</b>	<b>\$80,000</b>	<b>\$2,472,000</b>					<b>\$2,552,000</b>

PROJECT C-13



**MILWAUKIE / EL PUENTE ELEMENTARY  
SAFE ROUTES TO SCHOOL IMPROVEMENTS**

*From McLoughlin Boulevard to Edison Street*

**SAFE/SSMP IMPROVEMENTS**

*26th Avenue:* Fill in sidewalk gaps on the street, and grind and pave new overlay to the street surface from Lake Road to Lake Village Apartments.

*27th Avenue:* Replace portions of existing sidewalk, remove ADA barriers, and grind and pave a new overlay to the street surface from Lake Road to Washington Street.

*Oak Street:* Replace portions of existing sidewalk and repair or reconstruct asphalt pavement from Washington Street to Monroe Street.

*Washington Street:* Fill in sidewalk gaps on both sides of the street, replace portions of existing sidewalk, remove ADA barriers, and reconstruct asphalt pavement from McLoughlin Boulevard to 35th Avenue. May require relocation of water and stormwater utilities in addition to construction of new water quality facilities.

**Washington Street Sewer Replacement:** Replace sewer main from 34th Avenue to Sellwood Street. Both replacements would include service reconnection along the length of the pipe.

MH 2227 – 2226, Length 313', Depth upstream 12.58', Depth downstream 13.25', Number of services 7, Diameter 10". This project is required to address intruding roots and seal material which cause debris build-up requiring regular clearing.

MH 2228 – 2227, Length 462.9', Depth 7.33', Upstream 12.58', Downstream number of services 19, Diameter 10". This project is required to address intruding roots and add a manhole in the middle of the line to ease maintenance issues.

**Washington Street Storm Pipe Replacement - Phase II:** Replace undersized storm pipe in Washington Street.

**Operating Budget Impact:** *The paving projects could potentially increase ongoing operational needs due to the addition of new infrastructure. However, the wastewater replacements would decrease ongoing operational needs by restoring infrastructure to good condition.*

**Source:** SAFE, SSMP, Public Works Maintenance

**Submitted by:** Engineering, Public Works

	FY 2021	FY 2022	FY 2023	FY 2024	FY 2025	FY 2026	TOTAL
<b>Capital Cost:</b>							
Planning, Engineering, Design	\$250,000	\$478,000	\$184,000				\$912,000
Land/ROW Acquisition							n/a
Construction		\$220,000	\$4,976,000				\$5,196,000
<b>TOTAL EST. CAPITAL COST</b>	<b>\$250,000</b>	<b>\$698,000</b>	<b>\$5,160,000</b>				<b>\$6,108,000</b>
<b>Funding Source:</b>							
SAFE	\$100,000	\$190,000	\$2,054,000				\$2,344,000
SSMP	\$30,000	\$64,000	\$669,000				\$763,000
Stormwater	\$100,000	\$166,000	\$1,882,000				\$2,148,000
Wastewater		\$37,000	\$265,000				\$302,000
Wastewater SDC		\$220,000					\$220,000
Water	\$20,000	\$21,000	\$290,000				\$331,000
<b>TOTAL FUNDING</b>	<b>\$250,000</b>	<b>\$698,000</b>	<b>\$5,160,000</b>				<b>\$6,108,000</b>

PROJECT C-14



**LOGUS ROAD & 40TH AVENUE IMPROVEMENTS**

*40th Avenue, Logus Road, 42nd Avenue, 38th Avenue, Drake Street & 38th Avenue, 45th Court*

**SAFE/SSMP IMPROVEMENTS**

*40th Avenue:* Reconstruct roadway surface on 40th Avenue from Harvey Street to King Road.

*Logus Road:* Fill in sidewalk gaps, replace portions of existing sidewalk, remove barriers, and reconstruct roadway surface on Logus Road from 43rd Avenue to 49th Avenue.

**SSMP IMPROVEMENTS**

*42nd Avenue:* Reconstruct roadway surface on 42nd Avenue from Monroe Street to King Road.

**WASTEWATER SYSTEM IMPROVEMENTS**

*38th Avenue Repair:* Replacement recommended to address holes and a significant belly in the mainline that holds debris requiring quarterly flushing. The line also has two poorly constructed point repairs. MH 2120 – 2118: Length 253.6', Depth upstream 5.92', Depth downstream 5.67', Number of services 9, Diameter 8"

*45th Court Repair:* Repair of a failing upstream manhole which must be flushed regularly to clear debris build-up that blocks a service lateral. MH 3503 – 3316: Length 149.5', Depth upstream 8.5', Depth downstream 12.92', Number of services 3, Diameter 6"

**WATER SYSTEM IMPROVEMENTS**

*Drake Street & 38th Avenue:* Replace approximately 800 feet, upsize the existing cast iron 4-inch water main to 8-inch to improve fire flows in the neighborhood, and connect to the 8-inch water main on 40th Avenue. The project will include replacement of existing valves, reconnection of existing water services and hydrants, and pavement patching along the length of the pipe.

**Operating Budget Impact:** *This project would decrease ongoing operational needs by restoring infrastructure to good condition.*

**Source:** *WMP, SSMP, Public Works Maintenance* **Submitted by:** *Engineering, Public Works*

	FY 2021	FY 2022	FY 2023	FY 2024	FY 2025	FY 2026	TOTAL
<b>Capital Cost:</b>							
Planning, Engineering, Design		\$40,000					\$40,000
Land/ROW Acquisition							n/a
Construction			\$1,047,000				\$1,047,000
<b>TOTAL EST. CAPITAL COST</b>		<b>\$40,000</b>	<b>\$1,047,000</b>				<b>\$1,087,000</b>
<b>Funding Source:</b>							
SAFE		\$15,000	\$387,000				\$402,000
SSMP		\$10,000	\$254,000				\$264,000
Wastewater		\$5,000	\$144,000				\$149,000
Water		\$10,000	\$262,000				\$272,000
<b>TOTAL FUNDING</b>		<b>\$40,000</b>	<b>\$1,047,000</b>				<b>\$1,087,000</b>

PROJECT C-15



**WASTEWATER SYSTEM IMPROVEMENTS FY 2023**

*26th Avenue, 34th Avenue, 37th Avenue at Marketplace, 37th Avenue at Monroe Street, Lake Village Apartments, River Road*

**26th Avenue Sewer Repair:** To address a belly in the mainline and to reduce debris buildup. MH 4008 – 4007: Length 36.1', Upstream depth 7.6', Downstream depth 10', Number of services 0, Diameter 8"

**34th Avenue Sewer Replacement:** To address intrusion of seal material and multiple cracks and fractures that impact the integrity of the mainline. CO 2344 – 2018: Length 257', Upstream depth CO', Downstream depth 10', Number of services 6, Diameter 8"

**37th Avenue (Marketplace) Sewer Replacement:** To fix bellies in the mainline that collect grease from primarily the Milwaukie Marketplace. The downstream manhole can be eliminated and tie into the next 20 feet away. MH 3512 – 3511: Length 324.95', Upstream depth 8.42', Downstream depth 10.17', Number of services 1, Diameter 8"

**37th Avenue (at Monroe Street) Sewer Replacement:** To repair root intrusion into the main from mainline joints and lateral connections. MH 2075 – 2070: Length 263', Upstream depth 8.9', Downstream depth 9.5', Number of services 8, Diameter 8"

**Lake Village Apartments Sewer Replacement:** Construct 350 ft of 8-inch sanitary sewer line and associated manholes with a new alignment that would bypass lines currently located under the apartment complex and address access and maintenance issues.

**River Road Sewer Repair:** To address known inflow and infiltration (I&I) issues. The joints and lateral connections of the sewer mainline are failing and ground water is infiltrating. Eliminating the I&I will relieve the Kellogg Creek Waste Treatment Plant, reduce capacity issues, and maintain a good water-tight mainline. Medium infiltration 1-5 gallons a minute. This project may be eligible for a 10% cost share from CCSD#1 since it is a project designed to reduce I&I within the city. The project will be evaluated by CCSD#1 for its impact on I&I. CIPP is recommended for the mainline. MH 5052 – 5051: Length 304.0', Upstream depth 6.4', Downstream depth 6.2', Number of services 7, Diameter 8"

Reconnection of services and pavement patching along the replacement lines will be included in all projects.

**Operating Budget Impact:** This project would decrease ongoing operational needs by restoring infrastructure to good condition.

**Source:** WWMP, Public Works Maintenance **Submitted by:** Public Works

	FY 2021	FY 2022	FY 2023	FY 2024	FY 2025	FY 2026	TOTAL
<b>Capital Cost:</b>							
Planning, Engineering, Design							n/a
Land/ROW Acquisition							n/a
Construction			\$491,000				\$491,000
<b>TOTAL EST. CAPITAL COST</b>			<b>\$491,000</b>				<b>\$491,000</b>
<b>Funding Source:</b>							
Wastewater			\$491,000				\$491,000
<b>TOTAL FUNDING</b>			<b>\$491,000</b>				<b>\$491,000</b>



PROJECT C-16



**INTERNATIONAL WAY IMPROVEMENTS**

37th Avenue to Lake Road

**International Way SAFE/SSMP:** Fill in sidewalk gaps on both sides of the street, remove barriers, construct bicycle facility improvements, replace asphalt roadway surface from 37th Avenue to Lake Road.

**International Way & Wister Street Underground Storage:** Construct underground storage within piped storm system and install upsized pipe within existing system to eliminate potential flooding.

**International Way Sewer Replacement:** To address two significant bellies (211'-260' and 330'-340'), which create debris buildup that can go septic. Two plumber laterals may need grease traps. Replacement should be during dry season due to ground water issues and may require dewatering. MH 3033 - 3032: Length 354.2', Upstream depth 10.5', Downstream depth 11.5', Number of services 3, Diameter 12"

**International Way Pipe Extension:** Install of 820 feet of 12-inch ductile iron water main from Freeman Way to Mallard Way to tie together the entire length of International Way which would provide increased water flow capacity coupled with improved water quality. Project will include installation of a three-valve cluster fire hydrant at the midpoint to provide for proper unidirectional flushing and installation of a sample station at the northwest end of the new main. Accommodation of storm or wastewater systems may be necessary to accept large water volumes during flushing activities. Replacement of existing valves and reconnection of water services and hydrants will be included.

**Mallard Street SAFE:** Construct sidewalk from International Way to the Mallard Bridge.

**Operating Budget Impact:** *This project will potentially increase ongoing operational needs due to the addition of new infrastructure. However, pipe repairs and replacements will reduce operating expenditures due to the reduction of maintenance issues.*

**Source:** SAFE, SSMP, RTP, Public Works Maintenance

**Submitted by:** Engineering, Public Works

	FY 2021	FY 2022	FY 2023	FY 2024	FY 2025	FY 2026	TOTAL
<b>Funding Source:</b>							
SAFE				\$2,122,000			\$2,122,000
SSMP				\$679,000			\$679,000
Stormwater				\$174,000			\$174,000
Wastewater				\$144,000			\$144,000
Water				\$277,000			\$277,000
<b>TOTAL FUNDING</b>				<b>\$3,396,000</b>			<b>\$3,396,000</b>



PROJECT C-17



**NORTH MILWAUKIE IMPROVEMENTS**

**SAFE/SSMP IMPROVEMENTS**

*Main Street:* Fill in sidewalk gaps, replace portions of existing sidewalk, remove ADA barriers, and reconstruct asphalt pavement surface from Harrison Street to Ochocho Street/McLoughlin Boulevard.

*Mailwell Drive:* Construct continuous 6 feet-wide curbside ADA-compliant sidewalk on the north side of Mailwell Drive from Main Street to UPRR; construct new curbs where none are present; and reconstruct asphalt roadway from Main Street to UPRR.

**WASTEWATER SYSTEM IMPROVEMENTS**

*Main Street Sewer Replacement:* Sewer replacement to address multiple holes and fractures in the mainline, as well as significant buildup of fats, oils, and grease (FOG). An additional manhole will be installed due to the length of the line. MH 1157 – 1156: Length 445'; Upstream depth 4.83'; Downstream depth 5.33'; Number of services 13, Diameter 8"

**MAIN STREET STORM IMPROVEMENTS PHASE II**

Repair and/or replace the existing storm system that is located on private property and under buildings between Main Street and Omark Drive at Milport Road.

*Mailwell Drive Sewer Repair:* Repair to eliminate known inflow and infiltration (I/I), including those at the Kellogg Creek Waste Treatment Plant; replacing the existing 8-inch concrete pipe; installing one manhole to ease maintenance. Reconnect five existing services. May be eligible for a 10% costshare from CCSD#1. MH 1166 – 1029: Length 403.2'; Upstream depth 8'; Downstream depth 9.33'; Number of services 5, Diameter 8"

*Hannah Harvester Sewer Replacement:* Sewer replacement to fix a significant belly in the last 90 feet of the line. The line has heavy flow use, therefore the project will require bypass pumping. MH 1575 – 1144: Length 143.2'; Upstream depth 9.5'; Downstream depth 10'; Number of services 0, Diameter 8"

*17th Avenue Sewer Repair:* CIPP or line replacement due to substantial cracks and fractures that threaten the structural integrity of the mainline. MH – 1133 Length 233.4'; Upstream depth 4'; Downstream depth 5.42'; Number of services 2, Diameter 6"

*Roswell Street Sewer Repair:* CIPP repair or full replacement to eliminate known I/I issues to reduce groundwater, including those at the Kellogg Creek Treatment Plant. Removal of not-in-use laterals recommended. May be eligible for a 10% costshare from CCSD#1. MH 1204 – 1203: Length 362.8'; Upstream depth 8.83'; Downstream depth 8.33'; Number of services 8, Diameter 8"

*Stubb Street Sewer Repair:* CIPP repair or full replacement to eliminate known I/I issues, including those at the Kellogg Creek Treatment Plant. Removal of not-in-use laterals recommended. May be eligible for a 10% costshare from CCSD#1. MH 1192 – 1034: Length 367.7'; Upstream depth 5.5'; Downstream depth 5.4'; Number of services 9, Diameter 8"

**Operating Budget Impact:** Paving projects could potentially increase ongoing operational needs due to the addition of new infrastructure. However, pipe replacement would decrease ongoing operational needs by restoring infrastructure to good condition.

**Source:** SAFE, SSMP, Public Works Maintenance

**Submitted by:** Engineering

	FY 2021	FY 2022	FY 2023	FY 2024	FY 2025	FY 2026	TOTAL
<b>Funding Source:</b>							
SAFE					\$2,179,000		\$2,179,000
SSMP					\$929,000		\$929,000
Stormwater					\$641,000		\$641,000
Transportation					\$96,000		\$96,000
Wastewater					\$465,000		\$465,000
<b>TOTAL FUNDING</b>					<b>\$4,310,000</b>		<b>\$4,310,000</b>

PROJECT C-18



**SAFE & SSMP FY 2025 IMPROVEMENTS**

*Park Street, Lloyd Street, Beckman Avenue, Stanley Avenue*

**Park Street & Lloyd Street SAFE/SSMP Improvements:** Fill in sidewalk gaps on the street, replace portions of existing sidewalk, remove ADA barriers, and reconstruct asphalt surface from Home Avenue on Park Street, Beckman Avenue, Beckman Terrace, 56th Avenue, and Lloyd Street to Stanley Avenue.

**Stanley Avenue SSMP Improvements:** Reconstruct asphalt surface from Railroad Avenue to Lloyd Street.

**Water System Improvements:** Replace and upsize existing cast iron water mains to improve fire flows in the neighborhood. The project will include replacement of existing valves, and reconnection of existing water services and hydrants.

*Beckman Avenue:* Upsize from 6-inch water main to 8-inch; connect to the 12-inch main on Railroad Avenue and the 6-inch main on Park Street.

*Park Street:* Upsize from 6-inch to 8-inch; connect to 8-inch main on Home Avenue and 6-inch main or proposed 8-inch main on Beckman Street.

**Beckman Avenue Sewer Replacement:** Address multiple bellies in the mainline that can cause backup and property damage and install new manhole to ease maintenance. Full replacement is recommended and will include reconnection of services along replaced line. MH 3212 – 3211: Length 401.2', Upstream depth 10.25', Downstream depth 9.42', Number of services 11, Diameter 8"

**Operating Budget Impact:** *The paving projects could potentially increase ongoing operational needs due to the addition of new infrastructure. However, pipe replacements would decrease ongoing operational needs by restoring infrastructure to good condition.*

**Source:** SAFE, SSMP, WMP, Public Works Maintenance **Submitted by:** Engineering

	FY 2021	FY 2022	FY 2023	FY 2024	FY 2025	FY 2026	TOTAL
<b>Funding Source:</b>							
SAFE					\$918,000		\$918,000
SSMP					\$512,000		\$512,000
Wastewater					\$139,000		\$139,000
Water					\$1,128,000		\$1,128,000
<b>TOTAL FUNDING</b>					<b>\$2,697,000</b>		<b>\$2,697,000</b>

## PROJECT C-19 VEHICLE PURCHASES

The Public Works Fleet Division works constantly to ensure the profile of the fleet matches the needs, goals, and budgetary restrictions of the organization. The fleet needs to be right-sized as well as regularly evaluated for reduction or addition. Vehicles are examined through a number of filters to establish need:

- *Is the vehicle near the end of its useful life (typically 8-10 years or 100,000 miles)?*
- *How many miles per year does the vehicle travel? Is it low-use and could it be combined with another vehicle?*
- *What is the condition of the vehicle? Are repair costs anticipated? Is the vehicle value approaching 30% of residual value?*
- *Does the vehicle serve a critical function (snowplow, emergency response, etc.)?*
- *Is the vehicle task-specific? Could the function be subcontracted at a lower cost than the purchase and maintenance of a vehicle?*
- *Is it a passenger or light-duty vehicle that could be replaced with an EV or hybrid?*

Police Department includes three vehicle replacements at \$100,000 per year. FY 2021 includes an outstanding Purchase Order from FY 2020.

City Manager Department and Community Development Department includes \$20,000 in relation to the community engagement goal and site inspection/visits, respectively.

Public Works vehicle purchases include both Division-specific equipment as well as shared utility vehicles.

### FY 2021

- Utility shared 1-ton dump truck – \$60,000. Vehicle is 20 years old. Used for hauling excavation materials, rock for repairs, leaf debris, and equipment.
- PHEV Van for the Cross-Connection Specialist position –\$41,000. Vehicle was ordered but unavailable for delivery in FY 2020.
- PHEV Van for the Police Department – \$41,000. In addition to the \$150,000/year budget, as it was ordered but unavailable for delivery in FY 2020.

### FY 2022

- Utility wastewater service truck – \$60,000. Vehicle is 10 years old with 73k miles.
- Utility water chase truck – \$60,000. Vehicle is 10 years old with 50k miles.



- Utility wastewater VacCon truck – \$575,000. A 2008 vehicle that is heavily used. Maintenance on this vehicle is very expensive and it does not meet current diesel emission standards.
- General Fund CD staff vehicle – \$20,000. Vehicle is 2007, will convert to EV.

### FY 2023

- Utility shared 5-yard dump truck and plow – \$140,000. Vehicle is approaching 30 years old and does not meet current diesel standards. Used for moving spoils, materials to and from job sites, and plowing snow.
- Utility shared 5-yard dump truck and plow – \$140,000. Vehicle is approaching 30 years old and does not meet current diesel standards. Used for moving spoils, materials to and from job sites, and plowing snow.
- Utility shared backhoe – \$125,000
- Utility streets utility 2 truck – \$60,000

### FY 2024

- Utility water chase truck – \$40,000
- Utility streets sign shop truck – \$60,000
- Utility water van – \$60,000
- Utility stormwater utility crane truck – \$55,000
- Utility shared flatbed – \$60,000
- General Fund Engineering vehicle – \$40,000

### FY 2025

- Utility Stormwater Vactor Truck – \$575,000.
- A 2012 vehicle that is heavily used. Maintenance on this vehicle is very expensive.

**Operating Budget Impact:** General Maintenance

**Source:** Fleet Maintenance **Submitted by:** Fleet & Facilities

	FY 2021	FY 2022	FY 2023	FY 2024	FY 2025	FY 2026	TOTAL
<b>Funding Source:</b>							
General Fund	\$161,000	\$120,000	\$100,000	\$140,000	\$100,000		\$621,000
Stormwater	\$15,000		\$102,000	\$70,000	\$575,000		\$762,000
Transportation	\$15,000		\$162,000	\$75,000			\$252,000
Wastewater	\$15,000	\$635,000	\$102,000	\$15,000			\$767,000
Water	\$56,000	\$60,000	\$102,000	\$115,000			\$333,000
<b>TOTAL FUNDING</b>	<b>\$262,000</b>	<b>\$815,000</b>	<b>\$568,000</b>	<b>\$415,000</b>	<b>\$675,000</b>		<b>\$2,735,000</b>

PROJECT C-20

**LIFT STATION PUMP & SCADA CONTROLS REPLACEMENT**



A program that replaces the city's lift station pumps and SCADA controls prior to failures and/or service interruptions.

**Operating Budget Impact:** Complete preventative maintenance in advance of emergency repairs should reduce the possibility of sewer back up, claims against the city, and reduce operating expenditures.

**Source:** Public Works Maintenance

**Submitted by:** Public Works

	FY 2021	FY 2022	FY 2023	FY 2024	FY 2025	FY 2026	TOTAL
<b>Funding Source:</b>							
Wastewater	\$100,000	\$50,000	\$50,000	\$50,000	\$50,000		\$300,000
<b>TOTAL FUNDING</b>	<b>\$100,000</b>	<b>\$50,000</b>	<b>\$50,000</b>	<b>\$50,000</b>	<b>\$50,000</b>		<b>\$300,000</b>

PROJECT C-21



**WASTEWATER CAPITAL MAINTENANCE PROGRAM**

Projects under this program consist of repair of pipe where structural conditions exist or lining is necessary to prevent groundwater infiltration and/or stormwater inflow. Projects are identified based on routine system monitoring.

**Operating Budget Impact:** Regular maintenance will reduce operating expenditures.

**Source:** Public Works Maintenance

**Submitted by:** Public Works

	FY 2021	FY 2022	FY 2023	FY 2024	FY 2025	FY 2026	TOTAL
<b>Funding Source:</b>							
Wastewater	\$50,000	\$50,000	\$50,000	\$50,000	\$50,000	\$50,000	\$300,000
<b>TOTAL FUNDING</b>	<b>\$50,000</b>	<b>\$50,000</b>	<b>\$50,000</b>	<b>\$50,000</b>	<b>\$50,000</b>	<b>\$50,000</b>	<b>\$300,000</b>



**Opinion of Probable Construction Cost**

**Project P1 - Wastewater System Master Plan Update**

City of Milwaukee



<b>Bid Item</b>	<b>Description</b>	<b>Quantity</b>	<b>Unit</b>	<b>Unit Price</b>	<b>Cost</b>
1	2026 Wastewater System Master Plan Update	1	LS	\$ 200,000.00	\$ 200,000.00
2	2031 Wastewater System Master Plan Update	1	LS	\$ 200,000.00	\$ 200,000.00
3	2036 Wastewater System Master Plan Update	1	LS	\$ 200,000.00	\$ 200,000.00
4	2041 Wastewater System Master Plan Update	1	LS	\$ 200,000.00	\$ 200,000.00

**Project Costs** \$ 800,000.00

# Appendix K. System Development Charge Technical Memorandum

# City of Milwaukie

## WASTEWATER SYSTEM DEVELOPMENT CHARGE UPDATE

Final Report  
May 18, 2022

Washington  
7525 166th Avenue NE, Ste. D215  
Redmond, WA 98052  
425.867.1802

Oregon  
5335 Meadows Road, Ste. 330  
Lake Oswego, OR 97035  
503.841.6543

Colorado  
PO Box 19114  
Boulder, CO 80301-9998  
719.284.9168

[www.fcsgroup.com](http://www.fcsgroup.com)

This entire report is made of readily recyclable materials, including the bronze wire binding and the front and back cover, which are made from post-consumer recycled plastic bottles.



**FCS GROUP**  
Solutions-Oriented Consulting

# TABLE OF CONTENTS

---

Table of Contents .....	ii
Section I. Introduction .....	1
I.A. Project .....	1
I.B. Policy .....	1
I.C. SDC Background .....	2
Section II. SDC Calculation .....	4
II.A. Growth .....	4
II.B. Improvement Fee .....	5
II.C. Reimbursement fee Cost Basis .....	6
II.D. Calculated SDC .....	7
Section III. Implementation .....	9
III.A. Indexing .....	9
III.B. Scaling by Dwelling Unit Size .....	9
III.C. Comparisons .....	10
Table 1: Growth in EDUs .....	5
Table 2: Improvement Fee Cost Basis .....	6
Table 3: Reimbursement Fee Cost Basis .....	7
Table 4: Adjustments to the SDC Cost Bases .....	7
Table 5: Calculated SDC .....	8
Table 6: SDC Schedule .....	8
Table 7: Schedule for Single-Family Dwelling Units based on Total Living Area .....	10
Table 8: Wastewater SDC Comparisons with Comparable Cities .....	10

## Section I. INTRODUCTION

---

This section describes the project scope and policy context upon which the body of this report is based.

### I.A. PROJECT

The City of Milwaukie (City) imposes system development charges (SDCs) to recover eligible infrastructure costs and provide partial funding for the capital needs of its wastewater collection system. Wastewater collection SDCs are charged to all new development within the City's boundaries, both residential and commercial. For a typical single-family dwelling unit, the current wastewater collection SDC is \$1,269. The City also collects wastewater treatment SDCs for the Clackamas Water Environment Services (WES), who treats the City's wastewater. The wastewater treatment SDC is currently \$8,120.

In 2019, the City engaged Water Systems Consulting, Inc. (WSC) to begin updating its wastewater system master plan. At the same time, the City and WSC engaged FCS GROUP to update the City's wastewater collection SDC based on that new master plan.

### I.B. POLICY

SDCs are enabled by state statute, authorized by local ordinance, and constrained by the United States Constitution.

#### I.B.1. State Statute

Oregon Revised Statutes (ORS) 223.297 to 223.314 enable local governments to establish SDCs, which are one-time fees on development that are paid at the time of development or redevelopment that creates additional demand for park facilities. SDCs are intended to recover a fair share of the cost of existing and planned facilities that provide capacity to serve future users (i.e., growth).

ORS 223.299 defines two types of SDC:

- A reimbursement fee that is designed to recover “costs associated with capital improvements already constructed, or under construction when the fee is established, for which the local government determines that capacity exists”
- An improvement fee that is designed to recover “costs associated with capital improvements to be constructed”



ORS 223.304(1) states, in part, that a reimbursement fee must be based on “the value of unused capacity available to future system users or the cost of existing facilities” and must account for prior contributions by existing users and any gifted or grant-funded facilities. The calculation must “promote the objective of future system users contributing no more than an equitable share to the cost of existing facilities.” A reimbursement fee may be spent on any capital improvement related to the system for which it is being charged (whether cash-financed or debt-financed).

ORS 223.304(2) states, in part, that an improvement fee must be calculated to include only the cost of projected capital improvements needed to increase system capacity for future users. In other words, the cost of planned projects that correct existing deficiencies or that do not otherwise increase capacity for future users may not be included in the improvement fee calculation. An improvement fee may be spent only on capital improvements (or portions thereof) that increase the capacity of the system for which it is being charged (whether cash-financed or debt-financed).

In addition to the reimbursement and improvement fees, ORS 223.307(5) states, in part, that “system development charge revenues may be expended on the costs of complying” with state statutes concerning SDCs, including “the costs of developing system development charge methodologies and providing an annual accounting of system development charge expenditures.”

## I.B.2. Local Ordinance

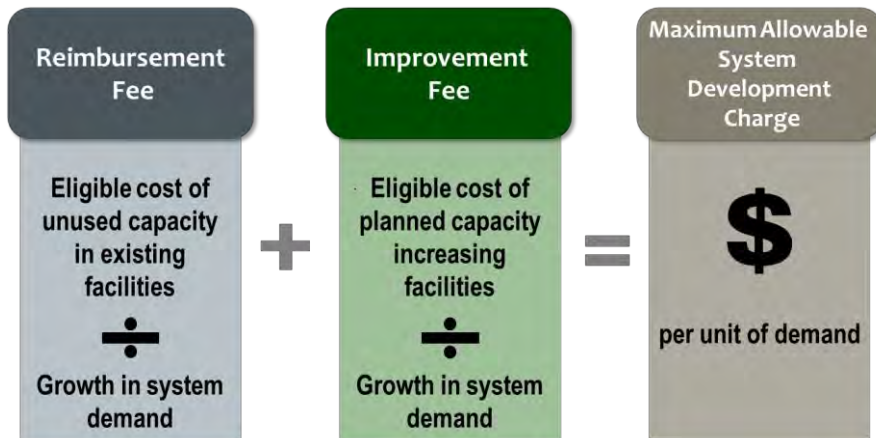
The City’s code authorizes and governs the imposition and expenditure of SDCs in the City.

## I.B.3. United States Constitution

The United States Supreme Court has determined that SDCs, impact fees, or other exactions that comply with state and/or local law may still violate the United States Constitution if they are not proportionate to the impact of the development. The SDCs calculated in this report are designed to meet all constitutional and statutory requirements.

## I.C. SDC BACKGROUND

In general, SDCs are calculated by adding a reimbursement fee component (if applicable) and an improvement fee component—both with potential adjustments. Each component is calculated by dividing the eligible cost by growth in units of demand. The unit of demand becomes the basis of the charge. Below is an illustration of this calculation:



## Section II. SDC CALCULATION

---

This section provides the detailed calculations of the maximum allowable wastewater SDC.

### II.A. GROWTH

The calculation of projected growth begins with defining the units by which current and future demand will be measured. Then, using the best available data, we quantify the current level of demand and estimate a future level of demand. The difference between the current level and the future level is the growth in demand that will serve as the denominator in the SDC calculations.

#### II.A.1. Unit of Measurement

A good unit of measurement allows an agency to quantify the incremental demand of development or redevelopment that creates additional demand for system facilities. A great unit of measurement allows an agency to distinguish different levels of demand added by different kinds of development or redevelopment.

For wastewater SDCs, demand is often measured in terms of equivalent dwelling units (EDUs), where one EDU is equal to the wastewater flow of a typical single-family dwelling unit. To calculate the demand incurred by other development types, EDUs can be assigned based on the differential flow rates of different meter sizes, or by counting the number of plumbing fixture units.

Currently, the City charges its wastewater SDC using the EDU method, and calculates the demand of multi-family dwelling units and commercial developments using the number of plumbing fixture units. An EDU is assumed to have 16 plumbing fixture units. This method is also used for this wastewater SDC calculation.

#### II.A.2. Growth in Demand

In 2020, the City had a total dry-weather flow of 1,621,328 gallons per day. The Wastewater System Master Plan Update estimates that the flow will grow to 2,006,855 gallons per day by 2040.

According to the wastewater system master plan, one EDU generates 115 gallons per day of flow. This implies that there are 14,099 EDUs in the system as of 2020. If EDUs grow at the same rate as dry-weather flow, there will be 17,451 EDUs in 2040. So, the growth in EDUs over the planning period is 3,352, and the growth share, or the percentage of EDUs in 2040 that will arrive between 2020 and 2040, is 19.21 percent.

These calculations are summarized in **Table 1** below. The growth of 3,352 EDUs will be the denominator for the SDC calculation.

**Table 1: Growth in EDUs**

	2020	2040	Growth	Growth Share
Dry-weather flow, gallons per day	1,621,328	2,006,855	385,527	19.21%
Flow per EDU, gallons per day	115	115		
Implied EDUs	14,099	17,451	3,352	19.21%

**Source:** Wastewater System Master Plan Update, Table 5-6 (2020 flow); Table 5-12 (2040 flow); Table 5-13 (flow per EDU)

## II.B. IMPROVEMENT FEE

An improvement fee is the eligible cost of planned projects per unit of growth that such projects will serve. Since we have already calculated growth (denominator) above, we will focus here on the improvement fee cost basis (numerator).

### II.B.1. Eligibility

A project’s eligible cost is the product of its total cost and its eligibility percentage. The eligibility percentage represents the portion of the project that creates capacity for future users. Where possible, specific details about a project can provide an eligibility percentage. However, when this is not possible, projects can still be sorted into three broad categories.

The first category is for projects that do not provide capacity for future users. Such projects may be purely replacement projects, or they may be solving a deficiency in the wastewater system. Projects in this category are zero percent eligible. The second category is for projects that are purely for future users, such as when new pipe is laid to provide for a new development. These projects are 100 percent eligible. Finally, projects that provide capacity that will be proportionately shared between current and future users are eligible at the growth share percentage discussed in the previous section, 19.21 percent.

### II.B.2. Improvement Fee Cost Basis

Projects in the improvement fee cost basis were taken from the City’s Wastewater System Master Plan Update. Each project except one was sorted into one of the three categories discussed above based on the descriptions provided in the plan and discussions with staff. The remaining project, “Pipe Upgrades,” had specific details provided by WSC to justify a unique eligibility percentage.

**Table 2** below shows all the projects in the wastewater system improvement fee cost basis. The eligibility for each project is shown in the SDC Eligibility column, and the SDC Eligible Costs column shows that full amount of the improvement fee cost basis is \$1.16 million.

**Table 2: Improvement Fee Cost Basis**

Project ID	Project Name	Timing	Cost	SDC Eligibility	SDC-Eligible
					Costs
CAP-1	Manhole Surveying	2023-2041	\$ 475,000	0.00%	\$ -
CAP-2	Pipe Upgrades	2029	819,000	20.01%	163,899
CAP-3	Flow Monitoring	2026-2041	124,000	19.21%	23,821
CAP-4	Harvey Street Improvements	2022	5,000	0.00%	-
C-1	Pipeline Rehabilitation and Replacement	2023-2041	7,239,000	0.00%	-
C-2	Pump Station Condition Assessments	2023	30,000	0.00%	-
C-3 thru 7	Pump Station Improvements	2026-2041	4,250,000	19.21%	816,447
C-8	Johnson Creek Siphon Inspection	2026	100,000	0.00%	-
C-9	Waverly South	2023	91,000	0.00%	-
C-10	Waverly Heights Sewer System Reconfiguration	2023-2025	3,404,000	0.00%	-
C-11	SCADA Design & Construction	2022	105,000	0.00%	-
C-12	Ardenwald North Improvements	2022	476,000	0.00%	-
C-13	Milwaukie/El Puente SRTS Improvements	2022-2023	522,000	0.00%	-
C-14	Logus Road & 40th Ave Improvements	2022-2023	149,000	0.00%	-
C-15	Wastewater System Improvements FY2023	2023	491,000	0.00%	-
C-16	International Way Improvements	2024	144,000	0.00%	-
C-17	North Milwaukie Improvements	2025	465,000	0.00%	-
C-18	SAFE & SSMP FY 2025 Improvements - Park/Lloyd/Stanley	2025	139,000	0.00%	-
C-19	Vehicle Purchases	2022-2024	752,000	0.00%	-
C-20	Lift Station Pump & SCADA Controls Replacement	2022-2025	200,000	0.00%	-
C-21	Wastewater Capital Maintenance Program	2022-2041	1,000,000	0.00%	-
R-1	S1 Island Pump Station Rebuild	2026-2041	-	0.00%	-
R-2	S3 Home & Monroe Pump Station Retrofit	2026-2041	-	0.00%	-
R-3	S5 Brookside Pump Station Retrofit and Pump Upgrade	2026-2041	-	0.00%	-
R-4	Bolted Manholes	2027	13,000	0.00%	-
P-1	Wastewater System Master Plan Update	2026-2041	800,000	19.21%	153,684
<b>Total</b>			<b>\$ 21,793,000</b>		<b>\$ 1,157,851</b>

**Source:** Wastewater System Master Plan Update, Table 10-1 (project list, timing, and cost); Water Systems Consulting (SDC

## II.C. REIMBURSEMENT FEE COST BASIS

A reimbursement fee is the eligible cost of the wastewater facilities available for future users per unit of growth that such facilities will serve. Since growth was calculated above, we will focus on the eligible cost of the wastewater facilities available for future users. That is, we will focus on the cost of reimbursable wastewater facilities.

### II.C.1. Capacity in Sewer Pipes for Infill Development

According to WSC, the current collection system has sufficient capacity to allow for infill development in the City's limits. Such infill development is expected to account for 19.21 percent of the City's 2040 population, and so 19.21 percent of the original cost of the City's pipes can be allocated to growth. The original cost of the pipes is \$16.93 million, and so \$3.25 million can be allocated to growth.

However, the City has \$964,578 in outstanding principal for debt related to the wastewater system. Because infill development will pay for this debt in either rates or property taxes, their share of the



principal must be removed from the reimbursement fee cost basis. So, a total of \$3.07 million can be included in the reimbursement fee cost basis.

These calculations are summarized in **Table 3** below.

**Table 3:** Reimbursement Fee Cost Basis

Original Cost of Sewer Pipes	\$ 16,930,032
Outstanding Principal	964,578
Capacity Available through 2040	19.21%
Reimbursable Cost	\$ 3,067,044

*Source: City staff (original cost of pipes, outstanding principal); Water Systems Consulting (available capacity)*

## II.D. CALCULATED SDC

This section combines the eligible costs from the improvement fee cost basis and the reimbursement fee cost basis and applies some adjustments. The result is a total SDC per EDU.

### II.D.1. Adjustments

The City must reduce its cost bases to account for any remaining fund balance in its current SDC fund. The improvement fee cost basis must be lowered by \$708,495, and the reimbursement fee cost basis must be lowered by \$20,061. These adjustments are shown in Table 4 below.

**Table 4:** Adjustments to the SDC Cost Bases

Unadjusted Improvement Fee Cost Basis	\$ 1,157,851
Improvement Fee Fund Balance	(708,495)
Improvement Fee Cost Basis	\$ 449,356
Unadjusted Reimbursement Fee Cost Basis	\$ 3,067,044
Reimbursement Fee Fund Balance	(20,061)
Reimbursement Fee Cost Basis	\$ 3,046,983

To account for the cost of complying with SDC law, the City should add \$73,800 to the full SDC cost basis.

### II.D.2. Calculated SDC

**Table 5** below summarizes the full calculation of the SDC. As shown, the full SDC is \$1,065 per EDU.

**Table 5: Calculated SDC**

<b>Cost Basis:</b>	
Improvement Fee	\$ 449,356
Reimbursement Fee	3,046,983
Compliance Costs	73,800
<b>Total Cost Basis</b>	<b>\$ 3,570,139</b>
Growth in EDUs	3,352
Improvement Fee per EDU	\$ 134
Reimbursement Fee per EDU	909
Compliance Fee per EDU	22
<b>Total SDC per EDU</b>	<b>\$ 1,065</b>

**Table 6** below shows the full wastewater SDC schedule.

**Table 6: SDC Schedule**

	EDUs	Calculated SDC
Single-Family Dwelling Unit	1.00 \$	1,065
Duplex, ADU (per Dwelling Unit)	0.65 \$	692
Other	1.00 \$	1,065
Per EDU	1.00 \$	1,065
Per Fixture Unit	0.06 \$	67

## Section III. IMPLEMENTATION

---

This section addresses practical aspects of implementing SDCs and provides a comparison with relevant jurisdictions.

### III.A. INDEXING

ORS 223.304 allows for the periodic indexing of SDCs for inflation, as long as the index used is:

- (A) A relevant measurement of the average change in prices or costs over an identified time period for materials, labor, real property or a combination of the three;
- (B) Published by a recognized organization or agency that produces the index or data source for reasons that are independent of the system development charge methodology; and
- (C) Incorporated as part of the established methodology or identified and adopted in a separate ordinance, resolution or order.

In accordance with Oregon statutes, we recommend that the City use the *Engineering News-Record* (ENR) Construction Cost Index (CCI) 20-City Average as the basis for adjusting SDCs annually.

### III.B. SCALING BY DWELLING UNIT SIZE

The City's wastewater collection system flows into a larger wastewater system managed by WES, who also treats the City's wastewater. WES sets the wastewater treatment SDC charged in the City and is considering moving to a different method for calculating the number of EDUs added by residential developments. Under this system, single-family housing units would have a different number of EDUs based on the square footage of the total living area in the residence. This EDU computation is based on research conducted on dwelling units in WES's jurisdiction.

The City can decide to charge its wastewater SDC to residential developments in the same way as WES without changing this methodology. The schedule for residential developments under this system is listed in **Table 7** below.

Note that the City has decided to call a dwelling unit with less than 500 square feet an accessory dwelling unit and evaluate it at a lower rate, which is different from how WES proposes to charge such units.

**Table 7:** Schedule for Single-Family Dwelling Units based on Total Living Area

	EDUs	Calculated SDC
< 500 sqft (use ADU rate)	0.60	\$ 639
500-800 sqft	0.70	\$ 745
800-1,799 sqft	0.90	\$ 958
1,800-2,999 sqft	1.00	\$ 1,065
3,000-3,799 sqft	1.10	\$ 1,171
≥ 3,800 sqft	1.20	\$ 1,278
Accessory dwelling unit (ADU)	0.60	\$ 639

WES is also considering calculating the EDUs added by non-residential developments based on a variety of factors rather than using plumbing fixture units. The City can elect to charge non-residential developments using the same EDU methodology as WES without changing this SDC methodology.

### III.C. COMPARISONS

This section provides comparisons for the city’s current and proposed SDCs against those of comparable jurisdictions. As shown in **Table 8**, if the wastewater collection SDC is implemented as proposed, the City will maintain its high position relative to other cities but drop slightly.

An important note is that not all SDCs shown are set by the relevant city; some are set by overlapping jurisdictions. This includes the City of Milwaukie, where \$8,120 of the total fee is set by WES.

**Table 8:** Wastewater SDC Comparisons with Comparable Cities





















Gladstone	13,758	
West Linn	12,363	
Oregon City	10,636	
<b>Milwaukie (current)</b>	9,389	
<b>Milwaukie (proposed)</b>	9,185	
Portland	7,235	
Gresham	6,568	
Beaverton	6,085	
Tigard	6,085	
Tualatin	6,085	
Wilsonville	5,905	
Lake Oswego	3,052	
Sherwood	859	

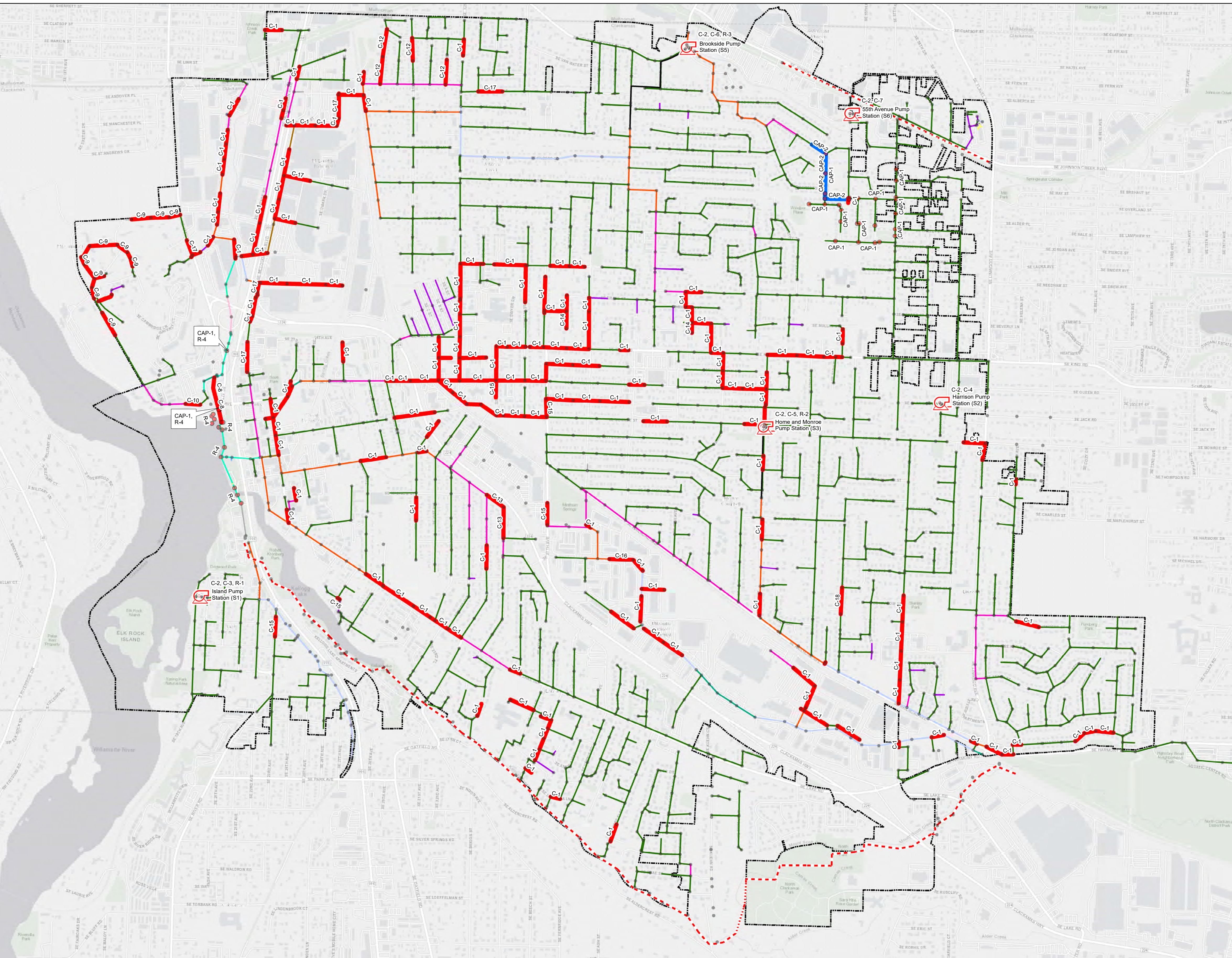
*Source: Survey by FCS Group, as of 12/7/2021*

# Appendix L. Map of CIP Projects



**Legend**

- Sewer Manholes
  - Manhole Project
  -  Pump Station Project
  -  Condition Project
  -  Capacity Project
  -  Force Main
  -  Interceptor
- Pipe Diameter**
-  Unknown
  -  4
  -  6
  -  7
  -  8
  -  10
  -  12
  -  15
  -  16
  -  18
  -  20
  -  24
  -  26
  -  27
-  City Boundary



1. Project P-1 is not shown on the map as it covers multiple assets across the system.

Esri, HERE, Garmin, (c) OpenStreetMap contributors, and the GIS user community