



Work Session

WS

Milwaukie City Council

COUNCIL WORK SESSION

City Hall Council Chambers, 10501 SE Main Street
& Zoom Video Conference (www.milwaukieoregon.gov)

REVISED AGENDA

MAY 21, 2024

(Revised May 17, 2024)

Council will hold this meeting in-person and through video conference. The public may attend the meeting by coming to City Hall or joining the Zoom webinar, or watch the meeting on the [city's YouTube channel](#) or Comcast Cable channel 30 in city limits. **For Zoom login** visit <https://www.milwaukieoregon.gov/citycouncil/city-council-work-session-349>.

To participate in this meeting by phone dial 1-253-215-8782 and enter Webinar ID 829 4863 6541 and Passcode: 642219. To raise hand by phone dial *9.

Written comments may be delivered to City Hall or emailed to ocr@milwaukieoregon.gov. Council may take limited verbal comments.

Note: agenda item times are estimates and are subject to change.

Page #

1. ~~Transportation System Plan (TSP) Goals and Policy – Discussion~~
(Removed from the agenda.)

2. Supervisory Control and Data Acquisition (SCADA) – Update (4:00 p.m.)
Staff: Peter Passarelli, Public Works Director

3. Staff Strategic Plan – Update (4:15 p.m.)
Staff: Emma Sagor, Acting City Manager

12

4. Council Reports (4:30 p.m.) (Added to the agenda.)

5. Adjourn (5:30 p.m.)

Meeting Accessibility Services and Americans with Disabilities Act (ADA) Notice

The city is committed to providing equal access to public meetings. To request listening and mobility assistance services contact the Office of the City Recorder at least 48 hours before the meeting by email at ocr@milwaukieoregon.gov or phone at 503-786-7502. To request Spanish language translation services email espanol@milwaukieoregon.gov at least 48 hours before the meeting. Staff will do their best to respond in a timely manner and to accommodate requests. Most Council meetings are broadcast live on the [city's YouTube channel](#) and Comcast Channel 30 in city limits.

Servicios de Accesibilidad para Reuniones y Aviso de la Ley de Estadounidenses con Discapacidades (ADA)

La ciudad se compromete a proporcionar igualdad de acceso para reuniones públicas. Para solicitar servicios de asistencia auditiva y de movilidad, favor de comunicarse a la Oficina del Registro de la Ciudad con un mínimo de 48 horas antes de la reunión por correo electrónico a ocr@milwaukieoregon.gov o llame al 503-786-7502. Para solicitar servicios de traducción al español, envíe un correo electrónico a espanol@milwaukieoregon.gov al menos 48 horas antes de la reunión. El personal hará todo lo posible para responder de manera oportuna y atender las solicitudes. La mayoría de las reuniones del Consejo de la Ciudad se transmiten en vivo en el [canal de YouTube de la ciudad](#) y el Canal 30 de Comcast dentro de los límites de la ciudad.

Executive Sessions

The City Council may meet in executive session pursuant to Oregon Revised Statute (ORS) 192.660(2); all discussions are confidential; news media representatives may attend but may not disclose any information discussed. Final decisions and actions may not be taken in executive sessions.



CITY OF MILWAUKIE

Memorandum

To: City Council
From: Joseph Briglio, Community Development Director
CC: Emma Sagor, Interim City Manager
Date: May 21, 2024
Re: Community Development Department Monthly Update

Community Development, Economic Development, & Housing	Planning	Building	Engineering
<ul style="list-style-type: none"> ▪ Economic Development ▪ Affordable Housing 	<ul style="list-style-type: none"> ▪ Comprehensive Plan Implementation ▪ Planning Commission ▪ Design and Landmarks Committee ▪ Land Use/ Development Review 	<ul style="list-style-type: none"> ▪ April Review 	<ul style="list-style-type: none"> ▪ CIP ▪ Traffic/Parking Projects ▪ Right-of-Way Permits ▪ PIP ▪ Document Administration

COMMUNITY DEVELOPMENT/ECONOMIC DEVELOPMENT/HOUSING

Economic Development

Downtown:

- The Collectors Mall, along with the adjacent store fronts, is currently under contract and the potential owners have been performing their due diligence by meeting with city staff on a number of building, engineering, and planning related issues.
- Historic City Hall: pFriem Beer and Keeper Coffee recently announced their new locations at Historic City Hall and the press has been very positive - <https://www.oregonlive.com/beer/2024/03/pfriem-family-brewers-to-open-first-portland-area-taproom.html>
 - The pFriem, Keeper, and Milwaukie flags flying in front of the building.
 - Henry Point Development has completed the demolition portion of the project as of March 2024. They have approved building permits and have started construction.
 - Construction completion is slated for winter/spring 2025.
- The Libbie's property is currently for sale: <https://www.loopnet.com/Listing/11056-11070-SE-Main-St-Milwaukie-OR/31458135/>

- [Cloud Pine](#) will be closing its doors later this summer. It was always intended to be a three-year project for the owners.
- *Milwaukie Station*: Eleven of the twelve cart spaces are occupied.

Milwaukie Marketplace:

- New Seasons held its Grand Opening on March 27. Ace Hardware is very close to opening. Nearby Mike's Drive-in is close to reopening as well (any day now).

Enterprise Zone:

- Staff have recently met with a business (plastics recycler) relocating to Milwaukie's north innovation area and interested in taking advantage of the North Clackamas Enterprise Zone tax incentives.
- The Overland Van Project was recently approved. Alpine Foods is in their final application stages and should receive approval soon. Swagelock has withdrawn its interest for now.

Urban Renewal Area Economic Development Programs:

- The Milwaukie Redevelopment Commission Citizen Advisory Committee (MRCCAC) convened in November and January to discuss the draft criteria and provide feedback on the emerging economic development programs.
- Staff presented the MRCCAC recommended program parameters on March 19th to the Milwaukie Redevelopment Commission and is currently in the process of building out the applications and grant agreements to help launch the program later this summer.

Affordable Housing

Sparrow Site:

- The city purchased the parcel ("main property") at the northeast corner of SE Sparrow Street and the Trolley Trail from TriMet for the purpose of land banking to support affordable housing several years ago. More recently, staff received a Metro Brownfields grant to support due diligence for the acquisition of 12302 SE 26th Avenue ("auxiliary property") from TriMet in order to help rectify access constraints to the main property. The city closed on the 12302 SE 26th Ave ("auxiliary") property and is considering next steps.

Coho Point:

- The Developer presented an update to the city council during its February 21, 2023, work session and requested a 12-month extension of the Disposition and Development Agreement (DDA) due diligence period because of extenuating circumstances involving supply chain and subcontractor timing issues related to the COVID-19 pandemic. The due diligence period was officially extended to March 31, 2024.
- Staff were notified on May 10, 2023, that Black Rock had submitted the CLOMR to FEMA. The review process typically takes several months, and FEMA has requested additional information from the applicant in September 2023, January 2024, and March 2024. The applicant has 90 days to address FEMA's comments and resubmit. In order to allow for the completion of the CLOMR/FEMA process, the City agreed to a fourth due diligence extension of September 30, 2024.

Construction Excise Tax (CET) Program:

- The CET Program was established by the city council in 2017 and codified within chapter 3.60 (Affordable Housing Construction Excise Tax) of the municipal code. The CET levy's a one percent tax on any development over \$100,000 in construction value. In example, a property owner who is building an addition that has an assessed construction value of \$100,000 would have to pay \$1,000 in CET to the city. As development continues throughout the city, the CET fund increases in proportionality.
- The city released its inaugural competitive bid process for CET funds through a formal Request for Proposals (RFP). This resulted in Hillside Park Phase I being awarded \$1.7M (requested \$2M) and the Milwaukie Courtyard Housing Project (Now called Milwaukie Shortstack) with \$300K (requested \$600K).
- On March 7, 2023, the city council authorized the city manager to execute the necessary grant agreements in the amounts listed above. The grants agreements for both projects have been signed and executed, and initial funding disbursements have occurred. Staff will now work with the applicants to ensure that their projects meet the conditions for funding.

PLANNING

Comprehensive Plan Implementation

- Neighborhood Hubs: Following a series of public workshops and an online survey, planning and community development staff are moving forward with proposed code amendments and an economic development toolkit for the Neighborhood Hubs project.

Staff held a work session with the City Council on December 19 to discuss the project status and next steps. Staff met with the Planning Commission in a work session on January 23 to provide an update and discuss a draft set of proposed code amendments. A public hearing with the Planning Commission was held on March 12. Measure 56 notices, 300-ft notices, and emails to NDAs and other stakeholders were sent the week of February 12. After a detailed presentation about the project and the proposed amendments, the Planning Commission voted unanimously to recommend approval of the amendments. The City Council hearing was held on May 7, where the Council heard the staff report, took public testimony, began deliberation, and provided staff with direction on additional information and revisions to the proposed code. The hearing was continued to July 16.

The required 30-day notice and code commentary was posted on February 7:
<https://www.milwaukieoregon.gov/planning/za-2024-001>.

Transportation Systems Plan (TSP)

- The TSP kicked off in October. Three Technical and Advisory Committee meetings have been held. To date, the committees have reviewed a plans and policy overview, financial forecast memo, a community profile, a community engagement plan, and a draft of the TSP goals and polices. The first community-wide meeting was held on March 21 to introduce the project and solicit feedback on the draft goals and polices. There was also an on-line survey open until April 17 to solicit feedback. The next Advisory Committee meeting will be held on Thursday, May 16, and the next Technical Committee meeting is scheduled for Wednesday, May 15. The Planning Commission will review the draft goals and policies on May 14. The City Council is scheduled to review the draft goals and policies on May 21.

Planning Commission

- ZA-2022-005: A Type V code amendment application related to Climate Friendly Equitable Communities rulemaking. The Planning Commission held a public hearing on February 14th and voted 6-0 to recommend approval of the code amendments. The City Council discussed the amendments during the regular session on March 7th. These code amendments were put on hold until the rulemaking process was complete in the fall of 2023. Staff held a public hearing with the Planning Commission on March 12, 2024, which unanimously recommended approval of the code package. A work session was held with City Council on April 2, 2024 and the public hearing is scheduled for May 21.
- ZA-2023-004: A Type V code amendment application to update the bicycle parking quantity and development standards for new and redevelopment projects. The Planning Commission held a work session on the proposed amendments on July 25th. These code amendments were put on hold until the rulemaking process was complete in the fall of 2023. Staff will be bringing these amendments to the Planning Commission and City Council at the same time as the Climate Friendly Equitable Communities code package above.
- ZA-2024-001: A Type V code amendment package related to Neighborhood Hubs. The Planning Commission public hearing was held on March 12, where the Commission voted

unanimously to recommend approval of the proposed amendments. The City Council held a public hearing on May 7. The hearing was continued to July 16.

- ZA-2023-006: A Type V code amendment package related to updates and clarifications in Title 17 – Land Division. The Planning Commission held a work session on November 14, 2023. A work session with the City Council was held on February 20. The Planning Commission hearing was held on April 9, where the Commission voted unanimously to recommend approval of the code package: <https://www.milwaukieoregon.gov/planning/za-2023-006>. City Council approved the code amendments at the hearing on April 16.
- DR-2024-001, VR-2024-002: A Type III application to establish a food park at 1915-1925 SE Scott St. The proposal includes areas for food carts/trucks; a covered, open-air seating area; and a permanent multi-story taproom building with a bar, indoor and roof-deck seating areas, and restrooms. The existing parking area will be improved and maintained to serve the site. The proposal requires downtown design review and a variance to minimum FAR in the DMU zone. The application was deemed complete; referrals were sent on May 1. The Planning Commission hearing has been tentatively scheduled for June 11.
- VR-2024-003: A Type III application seeking relief from the minimum side yard setback to allow the development of a 13-ft addition to the existing attached garage with a 0.5-ft setback rather than the required 10 ft. The addition would allow for the construction of additional living space while maintaining garage space. The addition would extend the existing non-conforming structure with a 0.5-ft setback. The application was deemed complete; referrals were sent on May 1. The Planning Commission hearing has been tentatively scheduled for June 11.
- Natural Resources code update: Planning Commission held a work session on April 9 focused on coordination with the City's residential tree code. In late May or early June, the Planning Commission will hold a work session regarding the Water Quality Resource standards and will continue to discuss the coordination with the residential tree code.
- CSU-2024-003: Initially processed as a Type I minor modification to the approved community service use (CSU) for Campbell Elementary School, this application is being reclassified as a Type III review. The proposal is to establish a public charter school at the site, where the former public elementary school ceased operations in 2011. Although the new student body will be smaller than before, the absence of busing has raised questions about potential traffic impacts in the surrounding neighborhood. The Planning Commission hearing will be scheduled soon.

Land Use/Development Review

- TFR-2024-002: A Type II application to review the Transportation Impact Study for a 44-unit cottage cluster on the vacant lot adjacent to 5606 SE Monroe St. The application was deemed complete. Referrals and public notices were sent on February 23. Comments were due by March 8. Several comments were submitted. A Notice of Decision approving the application with conditions was issued on April 19. The appeal period ended on May 2; no appeals were filed.
- MLP-2024-001: A Type II application to partition the property at 13200 SE Where Else Ln. The proposed division would place the existing house on its own lot and leave the remaining

property to the north to be further divided or otherwise developed to meet minimum density in the future. The natural resource area to the south would be placed in an undevelopable tract. The application has been deemed complete. The required public notice mailing and referral to other departments and agencies was sent on May 3, with a deadline for comments on May 17. A notice of decision will likely be issued during the week of May 20.

¹ Only land use applications requiring public notice are listed.

BUILDING

Permit data for	April	FY to Date:
New single-family houses:	0	12
New ADU's	1	5
New Solar	5	61
Res. additions/alterations	9	55
Commercial new	1	3
Commercial Alterations	6	70
Demo's	0	3
Total Number of Permits issued:		1214
<small>(includes fire, electrical, mechanical, plumbing, and other structural)</small>		
Total Number of Inspections:		3366
Total Number of active permits:		971

ENGINEERING

Capital Improvement Projects (CIP):

CIP 2018-A13 Washington Street Area Improvements

Summary: This project combines elements of the SAFE, SSMP, Water, Stormwater, and Wastewater programs. SAFE improvements include upgrading and adding ADA compliant facilities along 27th Ave, Washington St, and Edison St. Street Surface Maintenance Program improvements are planned for Washington Street, 27th Avenue, and Edison Street. The Spring Creek culvert under Washington Street at 27th Avenue will be removed, and a new structure added. The water system along Washington Street will be upsized from a 6" mainline to an 8" mainline. The stormwater system along Washington Street will be upsized from 18" to 24" storm lines. The project is being designed by AKS Engineering and Forestry.

Update: Construction has started as of March 2024. Currently, storm pipework is being replaced within Washington and Madison Street.

CIP 2016-Y11 Meek Street Storm Improvements

Summary: Project was identified in the 2014 Stormwater Master Plan to reduce flooding within this water basin. The project was split into a South Phase and a North Phase due to complications in working with UPRR.

Update: Contractor has completed installation of the pipeline between the Murphy Site and the Balfour Pond. The Balfour Pond is currently under construction. The City is coordinating with Union Pacific to construct a portion of the project in UPRR ROW between Kelvin and Roswell. Once the coordination is complete, construction is anticipated to proceed from June through July of 2024.

CIP 2022-W56 Harvey Street Improvements

Summary: The project includes water improvements and stormwater improvements on Harvey Street from 32nd Avenue to the east end, on 42nd Avenue from Harvey Street to Johnson Creek Boulevard, 33rd Avenue north of Harvey Street, 36th Avenue north of Harvey Street, Sherry Street west of 36th Avenue, 41st Street north of Wake Court, and Wake Court. Sanitary sewer work will be done on 40th Avenue between Harvey Street to Drake Street. The project also includes the installation of an ADA compliant sidewalk on Harvey Street from 32nd Avenue to 42nd Avenue and 42nd Avenue from Harvey Street to Howe Street. Roadway paving will be done throughout the project area.

Update: Century West Engineering was contracted for the design in July 2023. The project is currently at 30% design. An Open-House occurred January 31st with mainly positive feedback and additional requests for 60% design. The 60% design is expected in March for internal review and another open house will be scheduled for afterwards.

CIP 2021-W61 Ardenwald North Improvements

Summary: Project includes street repair on Van Water Street, Roswell Street, Sherrett Street, 28th Avenue, 28th Place, 29th Avenue, 30th Avenue, and 31st Avenue with a shared street design for bicycles, pedestrians, and vehicles. The sidewalk will be replaced on the north side of Roswell Street between 31st and 32nd Avenue. Stormwater catch basins in the project boundary will be upgraded, the water system will be upsized on 29th Avenue, 30th Avenue, 31st Avenue, and Roswell Street, and there will be wastewater improvements on 28th Avenue, 29th Avenue, and 31st Avenue to address multiple bellies and root intrusion to reduce debris buildup.

Update: Work is progressing on 100% design. Staff anticipates bidding the project this winter.

CIP 2022-A15 King Road Improvements

Summary: King Road (43rd Avenue to city limits near Linwood Avenue) SAFE/SSMP Improvements will replace existing sidewalk and bike lane with a multi-use path, improve stormwater system, replace water pipe, and reconstruct roadway surface.

Update: Additional storm improvement scope was added to the project. Existing condition investigations have been conducted. A meeting is scheduled to discuss design options.

Waverly Heights Sewer Reconfiguration

Summary: Waverly Heights Wastewater project was identified in the 2010 Wastewater System Master Plan. The project may replace approximately 2,500 feet of existing clay and concrete pipe.

Update: Authorization for the design contract with Stantec was approved by the Council on August 1, 2023. An engineering services agreement was executed with Stantec on Sept. 19, and the design effort was kicked off in early October of 2023. A flow monitoring program was initiated in October, and will continue through the wet season, concurrent with design. A public engagement plan was prepared in Fall of 2023, and a first set of informational material was mailed out to neighbors in the area in November, along with permit of entry forms. Stantec commenced with early site investigations in December of 2023, completed 30 percent design in January 2024, and is proceeding with the 60 percent design. A public open house is currently scheduled for May 9th, 2024, at City Hall.

Monroe Street Greenway

Summary: The Monroe Street Greenway will create a nearly four-mile, continuous, low-stress bikeway from downtown Milwaukie to the I-205 multi-use path. Once complete, it will serve as the spine of Milwaukie's active transportation network connecting users to the Max Orange Line, Max Green Line, Trolley Trail, 17th Avenue Bike Path, I-205 path, neighborhoods, schools, and parks. Funding grants through ODOT and Metro will allow the city to complete our 2.2-mile section of the Monroe Greenway from the Trolley Trail to Linwood Ave.

Segment Update:

East Monroe Greenway (37th to Linwood): Staff have come to an agreement with ODOT and contracted CONSOR for the design. A Kick-off meeting has occurred, and the site is being surveyed. An Open-House was hosted on February 29th for all of the Monroe Greenway, ODOT's Highway-224 project, the City's TSP, and Kellogg Creek Restoration and Community Enhancement Project. The City received a lot of positive feedback for moving forward with the project and requests for speed mitigation and intersection controls.

Monroe Street & 37th Avenue (34th to 37th): This segment is complete. It was constructed as part of the private development of the 7 Acres Apartments.

Western Monroe Greenway (Downtown to 34th): The city has come to an agreement with ODOT on an IGA that will transfer \$1.55 M in STIP funding to the city to construct this segment of the Monroe Street Greenway. The City has signed the IGA and is awaiting an ODOT signed copy. City staff has also contracted with 3J Consulting to negotiate work at the railroad crossings. The city will also contract a survey team to aid 3J.

Monroe Street & Highway-224 Intersection: This project has now been combined with a larger project which will mill and overlay Highway-224 from 17th Avenue to Rusk Road. The city will design and replace the underlying water main by October 2024 and ODOT will proceed to construction in the Fiscal Year 2026. An Open-House was hosted on February 29th for all of the Monroe Greenway, ODOT's Highway-224 project, the City's TSP, and Kellogg Creek Restoration and Community Enhancement Project. The City received concerns regarding the development of Highway-224 and Monroe Greenway pushing traffic from Monroe Street onto Penzance Street.

Kellogg Creek Restoration and Community Enhancement Project

Summary: Project to remove the Kellogg Creek dam, replace the McLoughlin Blvd. bridge, improve fish passage, and restore the wetland and riparian area. City of Milwaukie staff are part of the project Leadership Team, Core Technical Team, and the Technical Advisory Committee. The Leadership Team and Core Technical Team both meet monthly. In addition to city staff, these groups include staff from North Clackamas Watershed Council (NCWC), Oregon Department of Transportation (ODOT), and American Rivers. The Technical Advisory Committee (TAC) for the Kellogg Creek Restoration & Community Enhancement Project involves all collaborative partners that include the Confederated Tribes of the Warm Springs Indian Reservation of Oregon, the Confederated Tribes of Grand Ronde, Clackamas Water Environment Services, Metro, North Clackamas Parks and Recreation District, Oregon Department of Environmental Quality, Oregon Department of Fish and Wildlife, Oregon Division of State Lands, the Native Fish Society, and the Natural Resources Office of Governor.

Update: The project team submitted a Joint Permit Application (JPA) for sediment sampling activities, which was under review during March by the Oregon Dept of State Lands, US Army Corps of Engineers, and Oregon Dept of Environmental Quality. This work is critical as the results of the sampling effort are necessary to inform the overall Kellogg Project permit pathway and advance Project design beyond the conceptual level.

Traffic / Parking Projects, Issues

None.

Right-Of-Way (ROW) Permits (includes tree, use, construction, encroachment)

Downtown Trees and Sidewalks

Update: Staff have a contract with AKS; working on what type of design works best now and in the future with both the trees and sidewalks & curbs.

Private Development – Public Improvement Projects (PIPS)

1600 Lava

Update: This development on Lava drive will add a new 13-unit multi-family building. Public improvements for this project include a new sidewalk, an ADA ramp, and minor street widening. Building permits and public improvement site plans are currently under review.

Hillside

Update: Hillside currently has permits and site plans in review for all three buildings to be constructed under phase I. City staff is meeting with the developer on a weekly basis to ensure the project moves smoothly. Public improvements for this development include new roadway alignment, new sidewalk, ADA ramps, and new asphalt paving. Work is expected to begin onsite in June of this year.

Seven Acres Apartments (formerly Monroe Apartments) – 234 units

Update: Seven Acres has completed construction and is currently occupied. Public improvements for this development included a new bike path and sidewalk from Oak Street and Monroe Street to 37th Avenue and Washington Street. Public improvements are currently under warranty and will receive a final inspection after a one-year period before shifting over to the City for ownership.

Henley Place (Kellogg Bowl redevelopment)- 175 units

Update: Most of the street work has been completed; construction is in the project correction phase.

Elk Rock Estates – 5 lot subdivision at 19th Ave & Sparrow St.

Update: Most of the street work has been completed; construction is in the project correction phase. Project still needs to be closed. The land use entitlements have recently expired, so they will need to go back through the process to build units.

Shah & Tripp Estates – 8-lot subdivision at Harrison Street and Home Ave.

Update: Design plans have been approved. Waiting for developer to schedule a pre-construction meeting.

Jackson / 52nd – 5-unit development.

Update: Project is actively under construction. Public improvements such as the sewer main extension have been installed, however staff are waiting on developer to schedule testing. The remainder of the improvements will take place after the townhouses are constructed. Staff and developer have agreed on a development agreement to have the developer pave Jackson Street from Home to 52nd Ave. and be reimbursed for areas outside of their responsibility. Pre-construction meeting has concluded.

Walnut Estates

Update: Walnut estates has completed the majority of their construction and is currently in the final punch-list and cleanup phase. Public improvements for this development include new sidewalk, storm water facilities, and a new asphalt roadway. Once the final work is completed, this development will enter the one-year warranty period.

Bonaventure Senior Living – 170-units

Update: ROW permit has been issued and public improvements are currently under construction.

Document Administration

Master Plans

Summary: WSC is preparing the Stormwater System Plan.

WS 2. 5/21/24
Presentation

SCADA Update

May 21, 2024



What is SCADA

- Supervisory control and data acquisition (SCADA) is a system of software and hardware elements that allows industrial organizations to:
 - Control industrial processes locally or at remote locations
 - Monitor, gather, and process real-time data
 - Directly interact with devices such as sensors, valves, pumps, motors, and more through software
 - Record events



SCADA – Water and Wastewater

- Completed SCADA Master Plan – July 2019
- Awarded Contract for Design Services and SCADA Application Development - 2020
 - \$470K
 - Initially Planned two phases
 - Communication
 - Automation and Control
- Bid Communications Infrastructure
 - May 2022
 - No Bid
- Consolidated Phases – May 2023
 - bid from TSI for \$1.928M
 - Award June 6th, 2023
- Complete Late June 2024

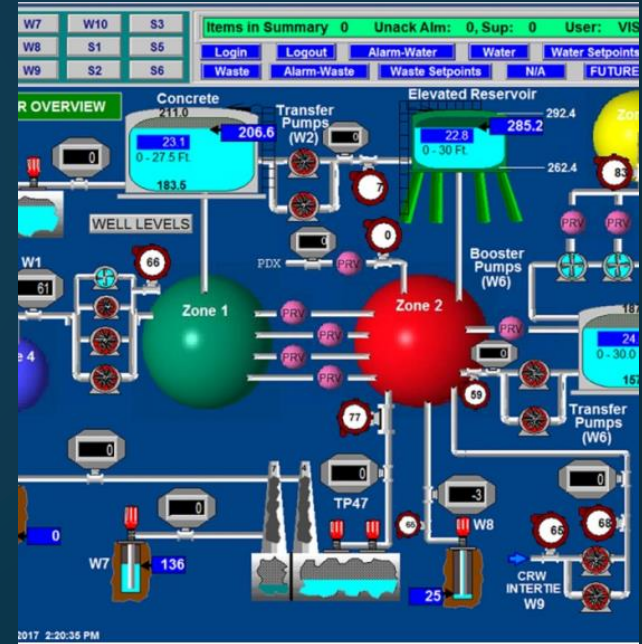

TP235	W2	W5	W7	W10	S3
TP47	W3	W6	W8	S1	S5
W1	W4	W6TRND	W9	S2	S6

Items in Summary 4 Unack Alm: 0, Sup: 0 User: VISITOR

Login	Logout	Alarm-Water	Water	Water Setpoints	System
Waste	Alarm-Waste	Waste Setpoints	N/A	FUTURE	TRENDS

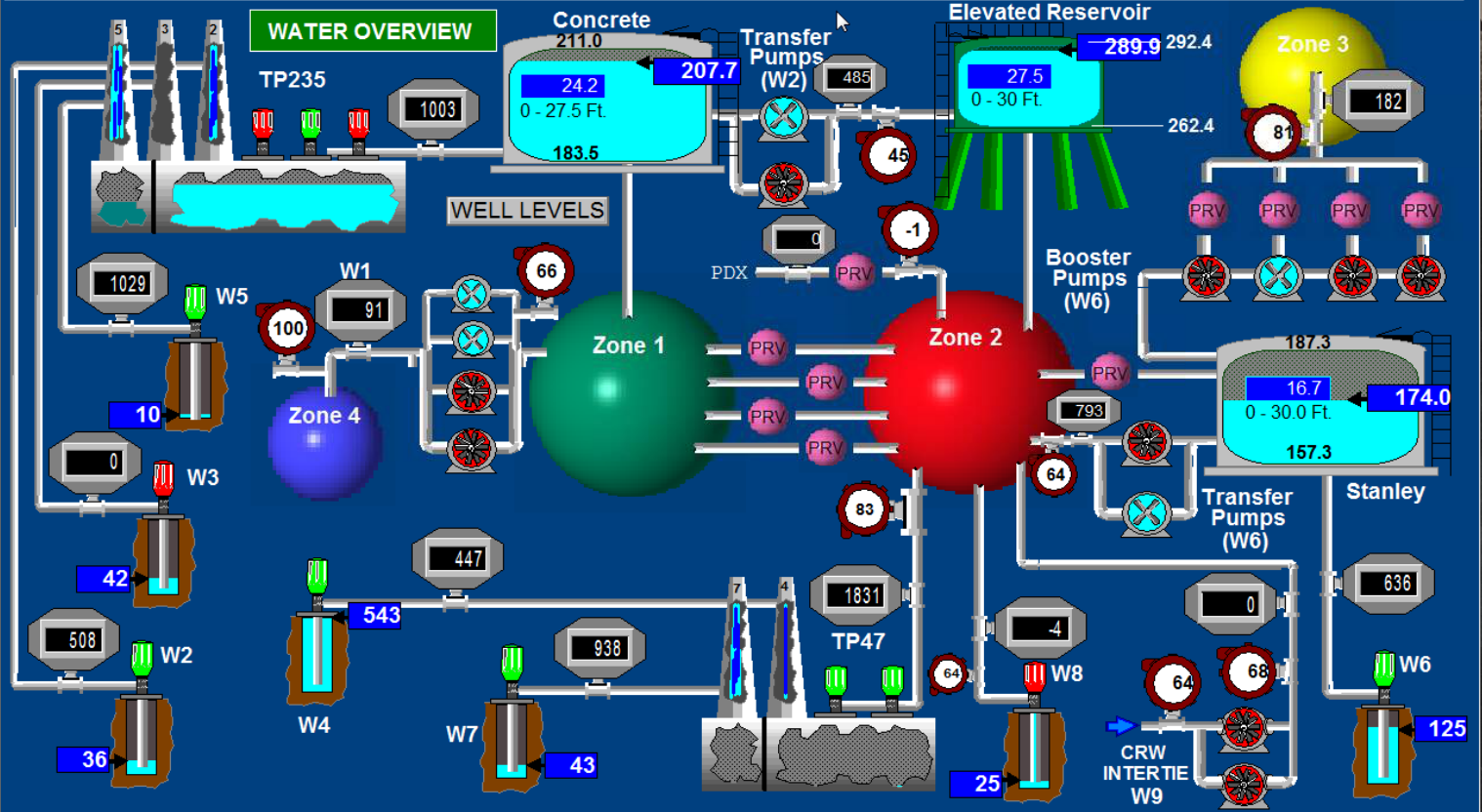

Water

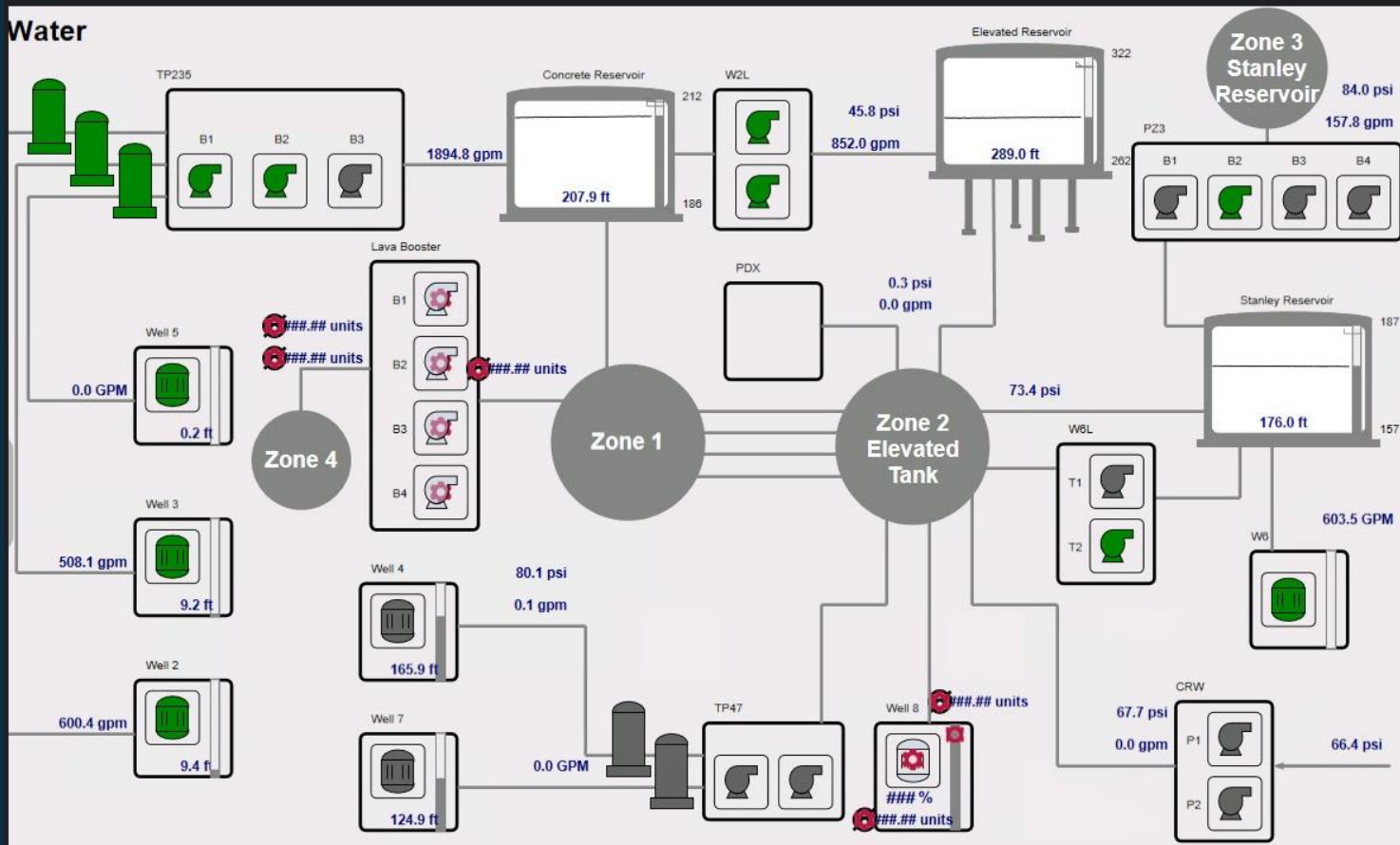

Timeline

- Week of 4/15 to 4/19: PZ3 and Well 6 - Complete
- Week of 5/6 to 5/10: TP47 and Well 7 (simultaneous startup) -Complete
- Week of 5/13 to 5/17: TP235 (with Wells 2 & 3) (simultaneous startup) - Complete
- Week of 5/20 to 5/24: Lava PS and Well 5 - In progress
- June : Well 8 , Punchlist items



Questions

Peter Passarelli

Public Works Director

passarellip@milwaukieoregon.gov



COUNCIL STAFF REPORT

To: Mayor and City Council

Date Written: May 16, 2024

From: Emma Sagor, Acting City Manager

Subject: **Organizational Strategic Plan Update**

ACTION REQUESTED

Council is asked to receive an update on the recently finalized three-year strategic plan for city staff and upcoming implementation steps.

HISTORY OF PRIOR ACTIONS AND DISCUSSIONS**ANALYSIS**

Between 2017 and 2019, hundreds of Milwaukians helped shape a [community vision statement](#) and [Comprehensive Plan](#), which chart a direction for the community's growth and development.

Beginning in mid-2023, the city, at the direction of the city manager's office, began work to create a near-term, three-year (2024-2027) organizational strategic plan that aligns day-to-day operations with the direction defined in the community vision and Comprehensive Plan.

The plan was developed through a multi-stage process:

Phase 1a. Vision/Mission/Values development (May – September 2023) – In this phase, staff developed vision, mission, and values statements to form the north stars of the strategic plan. In May 2023, all staff came together for a workshop to begin defining these statements. Then, a strategic plan steering committee was formed with representation from each city department. That group met bi-weekly throughout the summer to refine the feedback received at the all-staff workshop and prepare draft vision, mission, and values statements. All staff had a chance to weigh in and refine the drafts via an online survey in August.

Phase 2. Environmental scan (August – November 2023) – In this phase, staff consulted existing data and gathered new information to help understand the current state. A community-wide, statistically representative survey was conducted by FM3 Research in November 2023 to contribute to this environmental scan.

Phase 3. Priorities and objectives definition (October – December 2023) – In this phase, staff were engaged in a process of priority and objective definition. These represent the core areas and outcomes of focus for the next three years to best align and move toward the organization's vision/mission/values.

Phase 4. Tactic selection and prioritization (December – February 2024) – Once priorities and objectives were solidified, staff were engaged to help identify specific tactics—or actions—that will best help ensure we achieve the outcomes we desire. Staff also began the process of identifying realistic and informative performance metrics to help track progress. Measure refinement will continue as part of implementation.

The plan was completed in February 2024. Titled *Milwaukie Momentum* (Attachment 1), the plan will be used by staff to do the following:

- Inform budget development.
- Guide city departmental work and staff planning.
- Support transparent reporting on city performance and outcomes.
- Drive improvements that help make the City of Milwaukie an employer of choice and an exemplary public institution.

Staff are now moving into implementation. Cross-departmental work groups have been established to oversee plan implementation, track progress, provide updates and recommendations to leadership, and refine performance measures. Tools are in development to provide snapshot updates on tactic status, and staff will prepare an annual report in the first quarter of each calendar year to summarize progress and recommendations for improvement.

WORKLOAD IMPACT

While the strategic plan will help us prioritize projects and bodies of work for the near term, there will be no staff increases or reductions as a result of this effort. This is about aligning resources with the highest priorities—not adding or reducing positions. The specific efforts staff are asked to support may shift as a result of the defined priorities, objectives, and tactics.

CLIMATE IMPACT

While climate is not called out as a specific priority within the plan, several tactics throughout the plan were prioritized because they align with and support continued advancement of our Climate Action Plan (CAP) and community vision of a completely sustainable future. In addition, the adopted core values of “efficiency” and “accountability” are connected to the city’s commitments to reduce greenhouse gas emissions and invest in climate resiliency.

EQUITY IMPACT

Milwaukie’s equity and inclusion coordinator was a member of the Strategic Plan Steering Committee and highly involved in the plan development process. On December 12, 2023, Council passed Resolution 60-2023, supporting a multi-year equity plan. We have integrated the actions from that equity plan into *Milwaukie Momentum* to reinforce our commitment to equity, collaboration and accountability.

COORDINATION, CONCURRENCE, OR DISSENT

Staff were engaged at every step of the development process, including through surveys, departmental workshops, and an online comment form. Because this plan is organizationally focused, community engagement was conducted at the “inform” and “light consult” level via Council and Boards/Committee updates and the community survey conducted in November 2023.

STAFF RECOMMENDATION

Staff request Council provide feedback about the implementation strategy and how they would like to be kept informed of progress. Staff would also like to hear how Council would like to be involved in upcoming work to define equity indicators, which will support accountability for both the city’s strategic plan and the city’s equity plan.

ALTERNATIVES

None.

ATTACHMENTS

1. *Milwaukie Momentum: 2024 – 2027 Organizational Strategic Plan*

TEAM MILWAUKIE 2024-2027

STRATEGIC PLAN

MILWAUKIE MOMENTUM

Contents

Section	Pages
A note from the City Manager	i
Introduction	1-2
Team Milwaukie's North Stars	
• Vision	
• Mission	3
• Values	
Our 2024-27 Roadmap: Priorities, Objectives, Tactics and Measures	
• Support Our Employees	
• Work Smarter Together	4-16
• Revitalize Milwaukie	
• Help Milwaukians Most in Need	
Holding Ourselves Accountable	17-18

Team Milwaukie,

In 2022, I had an idea: What if we created a strategic plan just for *us*, the people who show up every day to power the City of Milwaukie?

From 2016 to 2020, staff had helped community members chart their direction through a community visioning and comprehensive planning process. But that same direction was lacking for our organization and our staff. With a new budget on the horizon, it was time to clarify what matters most to Team Milwaukie and what we need to do internally to deliver the things our community expects and deserves.

Pulling together a 3-year comprehensive strategic plan in less than 8 months? Impossible! But Team Milwaukie never shies away from a challenge. And with a little grit and a whole lot of heart, we came together and *pulled it off*.

Each team member's fingerprints are somewhere on this document. In total, we spent more than 20 hours in collaborative workshops, received more than 220 survey responses and comment forms, and had dozens of impactful small group conversations to co-create this strategy. I am so grateful for the time, energy and great suggestions you all contributed.

The following pages lay out a whole suite of priorities, objectives, and tactics that move us toward our new, clearly defined organizational north stars. But beyond what's in in the strategy itself, equally invaluable are the lessons I learned about our team over the last several months:

- **Innovation is our middle name.** Who needs fancy consultants—we have loads of expertise and creativity in-house we can harness to move our city forward.
- **We are one city, and we want to start acting like it.** We heard over and over that the most valuable part of this process was getting to collaborate with your colleagues across departmental lines.
- **Team Milwaukie cares about seeing our community thrive.** Whether or not it's a direct part of their day job, employees across the city share an interest in being part of revitalizing our town.

I commit to keeping the dialogue going throughout the implementation of *Milwaukie Momentum* so I can continue to hear and learn more from each of you.

I'm so excited to see how we make headway on this plan's ambitious priorities. As Millie the Goose reminds us, with Team Milwaukie, the sky is truly the limit.

With gratitude,



Ann

P.S. None of this could have happened without the Strategic Plan steering committee or incredible leadership from Assistant City Manager Emma Sagor. Thank you all.

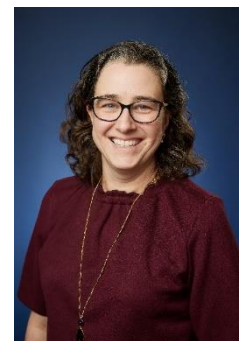

MILWAUKIE MOMENTUM

Introduction

Why create a strategic plan?

Every day, 155 full and part-time employees report to work for the City of Milwaukie. These dedicated people maintain our roads and pipes, keep our streets safe, plan and design new projects, and support the great quality of life in this vibrant community.

Team Milwaukie is doing tremendous work, but resources—time, money and people—are not infinite. As our community grows and changes, we need to check in and ask what we should create, change, and grow to best meet the needs of today and tomorrow.

Between 2017 and 2019, hundreds of Milwaukians helped craft a [community vision](#) and [Comprehensive Plan](#), which chart a direction for Milwaukie’s growth and development. These formative documents have guided policy and projects since their adoption. But until now, the city had not yet translated that long-range vision into a short-range strategy for the organization.

That’s what *Milwaukie Momentum* is: a 3-year roadmap for Team Milwaukie that articulates what we’re doing, why we’re doing it and how it moves us forward.

DEVELOPMENT PROCESS



We will use the strategic plan to:

- Inform budget decision making
- Guide departmental work and staff planning
- Support transparent reporting on performance and outcomes
- Drive improvements that make the City of Milwaukie an employer of choice and exemplary public institution

HOW TO READ THE STRATEGIC PLAN



The strategic plan is comprised of several interconnected parts:

- **The NORTH STARS:** Vision, Mission and Values
- **The ROADMAP:** Priorities, Objectives and Tactics
- **The ACCOUNTABILITY STRATEGY:** Performance measures

Pg. 3

Section 1: Our North Stars

Our vision, mission and values define the direction of the organization. The vision statement, written to complement the community’s vision, explains where the organization is heading; the mission statement summarizes our shared purpose and core services; and the values statements explain how city staff work together and who we want to be as an organization.

Section 2: Our 2024-2027 Roadmap

Our 3-year roadmap is centered around priorities Team Milwaukie feels are essential to live out city values, deliver on our mission, and advance toward the city’s vision. Priorities are broad, desired results we will aim to achieve by the end of the plan. Each priority is underpinned by three more specific objectives and performance measures to track progress toward achieving those outcomes. Finally, tactics are the shorter-term actions that we will complete to deliver on our objectives and priorities.

Pg. 4- 16

Section 3: Holding Ourselves Accountable

Our accountability strategy ensures this plan will not sit on the shelf. The strategic plan steering committee—an advisory group made up of representatives from each city department—collaboratively developed this strategy for tracking progress on plan implementation, evaluating outcomes, and making sure we walk our talk as an organization. *[Note: This strategy is forthcoming]*

Pg. 17 - 18

Connection to Milwaukie’s Equity Plan

On Dec. 12, 2023, city council passed [Resolution 60-2023](#), supporting a multi-year equity plan. We have integrated the actions from that equity plan into *Milwaukie Momentum* to reinforce our commitment to equity, collaboration and accountability.



Within this document, tactics identified with this symbol derive from the equity plan. The full plan is included as an appendix. For more information, contact Gabriela Santoyo-Gutierrez, equity & inclusion coordinator.



SECTION 1: TEAM MILWAUKIE'S NORTH STARS

Vision

Team Milwaukie is a **diverse and resilient** city government, **delivering effective public services** that make our community a **great place to be**.

Milwaukie's Community Vision:

"In 2040, Milwaukie is a flourishing city that is entirely equitable, delightfully livable, and completely sustainable."

[Read the full statement.](#)

Mission



We serve as stewards of our living and built environment to help create a safe and welcoming community for all

Values

We strive to be:

- **ACCOUNTABLE.** We build trust through transparency and take responsibility.
- **ACCESSIBLE.** We are responsive and remove barriers to participation.
- **EFFICIENT.** We use resources wisely to deliver work effectively.
- **COLLABORATIVE.** We work together, seek multiple perspectives and lead with empathy.
- **EQUITABLE.** We acknowledge history, meet people where they are and reduce disparities.

SECTION 2: 2024-2027 ROADMAP

In fall 2023, staff across the city weighed in on the top priorities they want to see Team Milwaukie tackle over the next three years. Employees provided feedback through departmental workshops, two all-staff retreats at Clackamas Community College, and three online surveys.

While each department faces unique challenges and is focused on different types of service delivery, the following priorities reflect four overarching themes that transcended all our planning conversations. All corners of the city organizational chart will play a part in advancing these priorities and achieving the measurable objectives within each.

The following pages explain more about why each priority will support Team Milwaukie’s vision, mission and values; what specific tactics the city will take on to make a difference on that priority; and a starting list of proposed performance measures we will use to track progress (these will continue to be refined over the first quarter of plan implementation). Tactics are generally ordered by when they will be undertaken—there are fewer tactics identified for 2025 and 2026 at this moment. We intend to review and refresh these tactics lists at least annually.

<p>Priority 1: Support Our Employees</p>	<p>Priority 2: Work Smarter Together</p>
<ul style="list-style-type: none"> • Objective 1.A: Retain staff and promote career development • Objective 1.B: Prioritize employee wellbeing • Objective 1.C: Train staff to meet growing and changing demands 	<ul style="list-style-type: none"> • Objective 2.A: Review and improve technology and processes to better deliver city services • Objective 2.B: Improve collaboration and communication across departments and levels of the organization • Objective 2.C: Coordinate public engagement to leverage resources and reach underrepresented voices
<p>Priority 3: Revitalize Milwaukie</p>	<p>Priority 4: Help Milwaukians Most in Need</p>
<ul style="list-style-type: none"> • Objective 3.A: Invest in our downtown and waterfront as part of the Urban Renewal Area • Objective 3.B: Support economic development by fostering partnerships and neighborhood hubs • Objective 3.C: Celebrate our unique community identity through city communications and events 	<ul style="list-style-type: none"> • Objective 4.A: Expand services for those experiencing crisis • Objective 4.B: Use data to prioritize investments where needs are the greatest • Objective 4.C: Build relationships with organizations serving vulnerable communities

PRIORITY 1

Support Our Employees

WHY THIS?

For Team Milwaukie to be a “*diverse and resilient city government*,” as called for in our vision, we need to attract and invest in an exceptional workforce.

Team members identified opportunities for the city to better train staff, and make Milwaukie an inclusive and healthy place to work. This priority is focused on measurably improving the employee experience, so more people want to join, stay with or recommend Team Milwaukie.

MAIN VALUES ADVANCED:

- Collaboration
- Equity
- Accessibility

OBJECTIVES





1.A Retain staff and promote career development

1.B Prioritize employee wellbeing

1.C Train staff to meet growing and changing demands



Priority 1: Support Our Employees

Tactics	Related objectives	Lead and supporting teams	Timing
Create an internal leadership development academy to help staff learn about other departments and develop leadership skills	1.A, 1.B, 1.C, 2.B	HR, City Manager's Office	2025
Increase collaborative decision making in and between departments using adopted values and priorities	1.B, 2.A, 2.B	Department Directors, Strategic Plan Steering Committee, HR	2024
Implement more regular staff surveys to track employee engagement metrics and inform employee support priorities, at least annually	1.A, 1.B	HR	2024
 Implement a standardized and robust equity training and learning calendar, including monthly equity chats, department-focused workshops, online trainings and "equity talks" guest speaker series	1.C, 2.B, 4.B, 4.C <i>*Tactic also included in city's Equity Plan</i>	Equity and Inclusion	2024
 Update and improve awareness of the city's ethics and equity reporting line and how staff can use it	1.A, 1.B <i>*Tactic also included in city's Equity Plan</i>	Equity and Inclusion, Finance, IT, OCR, City Manager's Office	2024
 Hold monthly equity and inclusion drop-in hours at all city facilities (City Hall, JCB, PSB, and Library)	1.A, 1.B, 1.C <i>*Tactic also included in city's Equity Plan</i>	Equity and Inclusion	2024
 Hold monthly employee resource groups (ERGs) and formalize policy for establishing and hosting ERGs	1.A, 1.B <i>*Tactic also included in city's Equity Plan</i>	Equity and Inclusion	2024
Train managers on how to conduct yearly stay interviews and develop individual development plans as part of coaching	1.A, 1.B	HR, Management Team	2024
Document growth opportunities and career development tracks for positions in multi-classification job families	1.A, 1.C	HR	2024

Create systems to support coverage during periods of short staffing	1.A, 1.B, 2.B	HR, Public Works, Police, Administration, Library, Community Development	2025
Improve in-facility or in-area wellness and mindfulness resources available to staff (e.g., basketball hoops, stretching rooms, access to local fitness facilities, mental health support)	1.B	HR, Facilities, Wellness Committee	2025
Prepare total compensation statements for each employee	1.A	HR	2025

POTENTIAL KEY PERFORMANCE MEASURES | Support Our Employees

Objective	Starting Point Key Performance Measures
1.A Retain staff and promote career development	<ul style="list-style-type: none"> • Margin of difference between average Milwaukie salary and average from 10 comparator cities (HR data) • Overall staff turnover rate and turnover rate of staff who identify as BIPOC (HR data) • Percentage of employees who feel training and development activities are helping them to develop their career (Employee survey) • Percentage of employees who say they plan to look for a job outside of the city within the next two years (Employee survey)
1.B Prioritize employee wellbeing and staff retention	<ul style="list-style-type: none"> • Percentage of employees who feel they achieve a good balance between their work and private life (Employee survey) • Percentage of employees who report liking the kind of work they do (Employee survey) • Number of overtime hours worked (HR data) • Percentage of employees who report feeling comfortable bringing their full selves to work (Employee survey)
1.C Train staff to meet growing and changing demands	<ul style="list-style-type: none"> • Percentage of employees who feel they could take time off and their responsibilities could be covered (Employee survey) • Percentage of employees who feel they get the training they need to do their job well (Employee survey) • Hours of training completed (NeoGov)

PRIORITY 2

Work Smarter Together

WHY THIS?

Team Milwaukie's vision describes an organization that "[delivers] effective public services." As technology evolves, demands change and our community grows, we must ensure we are maximizing every dollar and every minute.

Team members highlighted opportunities for our city to work *smarter* in the years ahead, improving services for our constituents and working conditions for our employees.

MAIN VALUES ADVANCED:

- Efficiency
- Collaboration
- Accountability
- Accessibility
- Equity

OBJECTIVES



2.A. Review and improve technology and processes to better deliver services

2.B. Improve collaboration and communication across departments and levels of the organization

2.C. Coordinate public engagement to leverage resources and reach underrepresented voices



Priority 2: Work Smarter Together

Tactics	Related objectives	Lead and supporting teams	Timing
Update the city's organizational chart and develop a list of services by department	2.B, 1.A	HR, Strategic Engagement Team, OCR	2024
Conduct an audit of standard operating procedures (SOPs) to identify regulatory requirements, existing procedures, and documentation gaps, and prioritize SOPs for update and improvement	2.A	Department Directors in conjunction with staff	2024
Inventory software systems/subscriptions and hardware assets and make a forward-looking strategy to tackle integration and duplication issues	2.A, 2.B	IT, all teams	2024
 Create an engagement database of community members/businesses/organizations that all staff can access and use to document relationships	2.C <i>*Tactic also included in city's Equity Plan</i>	Strategic Engagement Team, GIS, Community Engagement Forum	2024-25
Create and maintain a shared citywide engagement calendar	2.C	Strategic Engagement Team	2024
 Update the city's community engagement guide to include an equity framework for designing effective, equitable engagement strategies	2.C, 4.B, 4.C <i>*Tactic also included in city's Equity Plan</i>	Equity and Inclusion, Strategic Engagement Team	2024
 Collaboratively craft a strategy for engaging underrepresented groups on priority citywide efforts, including Neighborhood Hubs, the Transportation System Plan, and Capital Improvement Plan update	2.C, 3.B <i>*Tactic also included in city's Equity Plan</i>	Equity and Inclusion, Strategic Engagement Team, Community Development	2024-27
Implement an internal communications strategy, including a more robust, interactive intranet to	2.A, 2.B, 1.C	Strategic Engagement Team, IT, HR, Library	2024-2025

support better internal communication and document standard SOPs			
Hold staff trainings on critical software systems and implement intentional cross-training	2.A, 2.B, 1.C	IT, OCR, Asset Management Coordinator	2024/2025
Establish a technology and process governance committee responsible for documenting city processes and prioritizing process improvement projects	2.A, 2.B, 2.C	City Manager's Office, IT	2025
Refresh the city's public website, improving back-end interface and usability	2.A, 2.B, 2.C, 3.C	Strategic Engagement Team, all teams	2025/2026

POTENTIAL KEY PERFORMANCE MEASURES | Work Smarter Together

Objective	Starting Point Key Performance Measures
2.A. Review and improve technology and processes to better deliver services	<ul style="list-style-type: none"> Percentage of employees who feel they have the resources they need to do their job well (Employee survey) Percentage of community members who feel city staff are efficient (Community survey) Number of processes documented and added to central process library Number of reviews/audits performed by the technology and process governance committee
2.B. Improve collaboration and communication across departments and levels of the organization	<ul style="list-style-type: none"> Percentage of employees who feel people across the city collaborate effectively to get the job done (Employee survey) Percentage of employees who report they know what is going on around the city (Employee survey)
2.C. Coordinate public engagement to leverage resources and reach underrepresented voices	<ul style="list-style-type: none"> Number of community members and organizations cataloged in an engagement database Number of individual and organizational partnership meetings held Number of engagement activities held specifically focused on reaching underrepresented groups

PRIORITY 3

Revitalize Milwaukie

WHY THIS?

Team Milwaukie’s vision speaks to the community being “a great place to be.” Our staff feel called to this work because their efforts help Milwaukie become a place people want to live, visit, do business in, or come to have fun.

This priority speaks to actions we can take to foster Milwaukie’s unique identity and celebrate its story. Whether we are physically building infrastructure, putting on events, or upholding policies that keep our city livable, we all have a role to play in Milwaukie’s revitalization.

MAIN VALUES ADVANCED:

- Collaboration
- Accountability
- Accessibility
- Equity

OBJECTIVES



3.A. Invest in our downtown and waterfront as part of the Urban Renewal Area

3.B. Support economic development by fostering partnerships and neighborhood hubs

3.C. Celebrate our unique community identity through city communications and events.



Priority 3: Revitalize Milwaukie

Tactics	Related objectives	Lead and supporting teams	Timing
 Refresh the city's annual events calendar and events program to celebrate Milwaukie's identity and support community groups in putting on multicultural celebrations	3.C, 4.C <i>*Tactic also included in city's Equity Plan</i>	Strategic Engagement Team, Equity and Inclusion, OCR, Library, MPD	2024
Support the establishment of a local business alliance	3.B, 3.C	Community Development, URA/MRC, Strategic Engagement Team, Finance	2024
 Create and implement a youth engagement strategy	3.C, 2.C, 4.C <i>*Tactic also included in city's Equity Plan</i>	Strategic Engagement Team, Equity and Inclusion, Community Engagement Forum, OCR, Library	2024
 Support and amplify local minority-owned businesses	3.B	Strategic Engagement Team, Community Development, Finance	2024-27
Increase downtown safety and appeal, including through right-of-way maintenance responsibilities	3.A, 4.A, 3.C	Community Development, Urban Renewal Area (URA)/Milwaukie Redevelopment Commission (MRC) MPD, Public Works	2025
Help connect local businesses to financial assistance and grant opportunities	3.B	Community Development, URA/MRC Strategic Engagement Team, Finance	2025
Create more outdoor covered spaces as part of URA investment and parks	3.A	Community Development,	2025

		URA/MRC, Public Works	
Invest in improvements to Milwaukie Bay Park within the city's control and budget to increase access, safety, and accessibility	3.A, 3.C	City Manager's Office, Public Works, Community Development	2026

POTENTIAL KEY PERFORMANCE MEASURES | Revitalize Milwaukie

Objective	Starting Point Key Performance Measures
3.A. Invest in our downtown and waterfront as part of the Urban Renewal Area	<ul style="list-style-type: none"> • Number of businesses operating in downtown Milwaukie • Number of safety incidents related to sidewalks/crosswalks in downtown • Number of event permits issued downtown or in Milwaukie Bay Park • Dollars invested in the Urban Renewal Area (MRDC)
3.B. Support economic development by fostering partnerships and neighborhood hubs	<ul style="list-style-type: none"> • Dollars invested across Milwaukie neighborhoods tied to neighborhood hub policy changes • Dollars invested in infrastructure to support neighborhood hubs • Number of businesses associated with a local business alliance
3.C. Celebrate our unique community identity through city communications and events.	<ul style="list-style-type: none"> • Number of people attending city events. • Demographics of people attending city events. • Number of people engaging with the City of Milwaukie social media accounts

PRIORITY 4

Help Milwaukians Most in Need

Team Milwaukie’s role as stewards of our community calls us to look out for those who need help the most. Each department has ways they can be a part of creating “a safe and welcoming community for all.”

This priority focuses on initiatives that address growing crises facing our community members while equipping staff with skills, resources, and training that better enable us to support our fellow Milwaukians.

WHY THIS?

MAIN VALUES ADVANCED:

- Collaboration
- Accountability
- Accessibility
- Equity

OBJECTIVES





4.A. Expand services for those experiencing crisis

4.B. Use data to reduce barriers and invest where needs are the greatest.

4.C. Build relationships with organizations serving vulnerable communities.



Priority 4: Help Milwaukians Most in Need

Tactics	Related objectives	Lead and supporting teams	Timing
Conduct outreach with community members, service providers, and agency partners to fully understand ways the city is positioned to best help people in crisis	4.A, 4.B, 4.C	Behavioral Health, Library, Equity and Inclusion	2024
Compile and share a community resource list that staff and community members can use	4.A, 4.C, 2.C	Behavioral Health, Library, Equity and Inclusion	2024
 Relaunch internal Equity Committee as a partner in implementing the city's equity plan alongside the Equity Steering Committee	4.B, 4.C, 1.B, 1.C <i>*Tactic also included in city's Equity Plan</i>	Equity and Inclusion	2024
 Ensure staff are aware of increase utilization of language translation and interpretation support resources	4.A, 4.C, 1.C, 2.A <i>*Tactic also included in city's Equity Plan</i>	Equity and Inclusion, Strategic Engagement Team	2024
 Build relationships with trusted leaders and organizations in and around the community who serve Milwaukians of marginalized identities and cocreate strategies for ongoing and mutually beneficial engagement	2.C, 4.A, 4.B, 4.C	Equity and Inclusion, Strategic Engagement Team, Community Development, Library	2024-27
Train staff on de-escalation and crisis management techniques	4.A, 4.C, 1.C	Behavioral Health, Library , all teams with duties that require public interaction	2024-25
 Support implementation of a 23-hour stabilization center and emergency cooling/warming shelters	4.A, 4.C <i>*Tactic also included in city's Equity Plan</i>	City Manager's office, Community Development, Equity and Inclusion, Library, MPD	2024-2025
Ensure staff are aware of volunteer opportunities in the community and clarify policies around staff participation during work hours	4.A, 1.B, 1.C	Strategic Engagement Team, Equity and Inclusion, HR	2025

 Create community data dashboards that track critical equity and public safety indicators and help inform city decision making	4.B, 2.A, 2.C <i>*Tactic also included in city's Equity Plan</i>	Equity and Inclusion, Strategic Engagement Team, MPD	2024-25
Create a collaborative strategy for what facilities and teams will budget for and provide supplies for people in need, and make sure this strategy is communicated across all departments	4.A, 4.C	Behavioral Health, Facilities, Equity and Inclusion	2025
Implement more public toilets, including considering where and when toilets at city-owned and maintained facilities can be used by members of the public	4.A, 3.A	Facilities, Community Development, Behavioral Health	2026 (budget permitting)

POTENTIAL KEY PERFORMANCE MEASURES | [Help Milwaukians Most in Need](#)

Objective	Starting Point Key Performance Measures
4.A. Expand services for those experiencing crisis	<ul style="list-style-type: none"> • Number of people served by Milwaukie's behavioral health services • Number of individuals served by new shelters in Milwaukie • Number of hours new shelters were operational in Milwaukie per year • Number of service provider meetings held at the library
4.B. Use data to reduce barriers and invest where needs are the greatest.	<ul style="list-style-type: none"> • Number of staff trained on how to apply an equity framework to their decision making • Number of applications of the equity framework documented across departments • Number of equity performance indicators developed and included on a public dashboard
4.C. Build relationships with organizations serving vulnerable communities.	<ul style="list-style-type: none"> • Number of referrals made by city staff to local service organizations. • Number of community-based organizations cataloged in an engagement database • Number of relationship building and partnership meetings held • Number of hours community organizations spend in city buildings

SECTION 3: HOLDING OURSELVES ACCOUNTABLE

Implementation and oversight

Milwaukie Momentum is about making moves. We do not want this plan to sit on the shelf and are committed to advancing the work defined on the previous pages. To oversee implementation of the priorities, objectives, and tactics in the plan, we are establishing four work groups with representatives from all city departments. These groups will be responsible for working with implementation leads to prioritize tactics, track and report on progress,

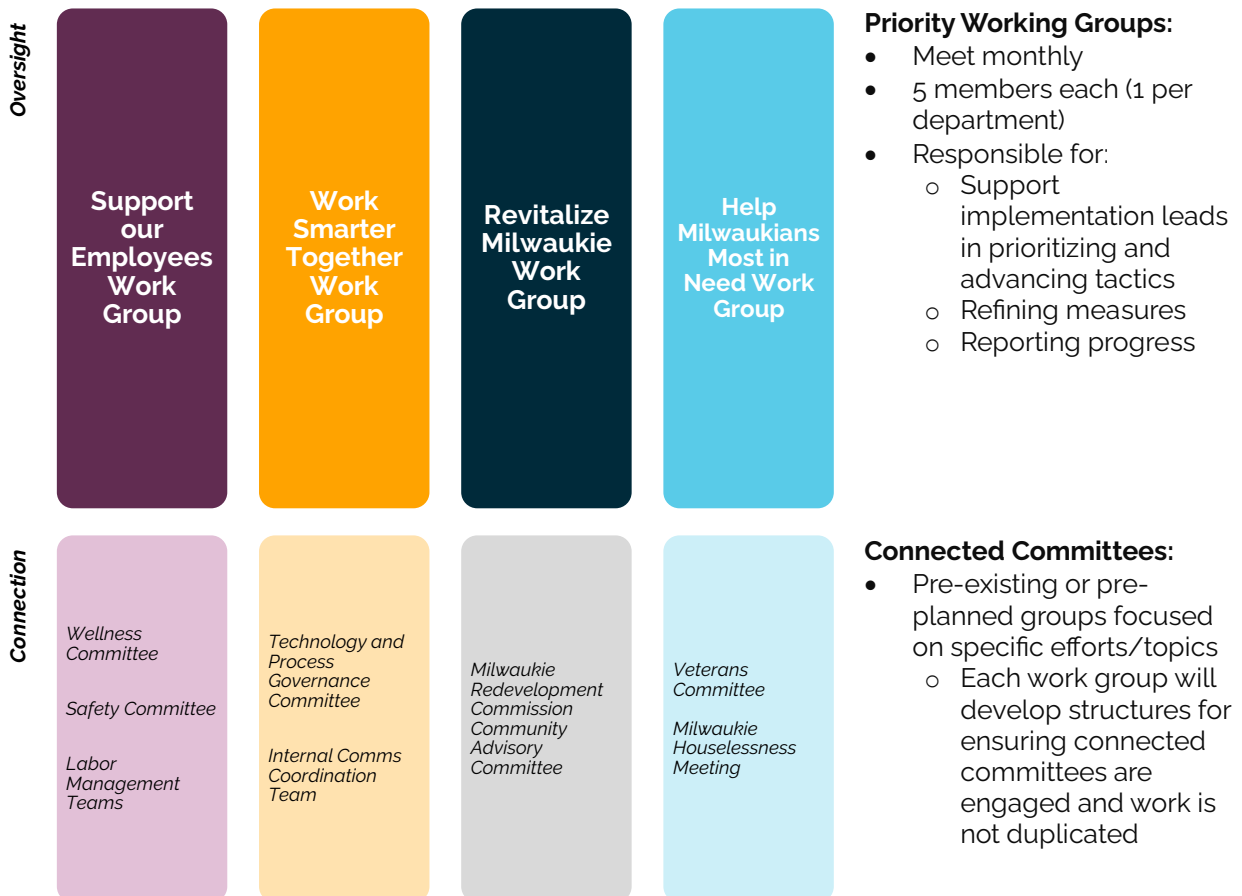

Employees who are interested in participating on the work groups will have the opportunity to apply in April 2024. Participants can serve on only one work group at a time.

Monitoring and reporting

The work groups will collaborate to prepare snapshot updates and comprehensive reports throughout the year, keeping their colleagues apprised of progress made and ways to get involved. All updates and reports will be shared via all staff emails, at quarterly All Hands meetings, and on the employee intranet.

- **Quarterly:** Status updates at All Hands meetings
- **Semi-annual:** Representatives of the work groups present recommendations at Directors' retreats
- **Annually:** Comprehensive reports, including data for performance measures
- **Ongoing:** All information published on the employee intranet

A living document

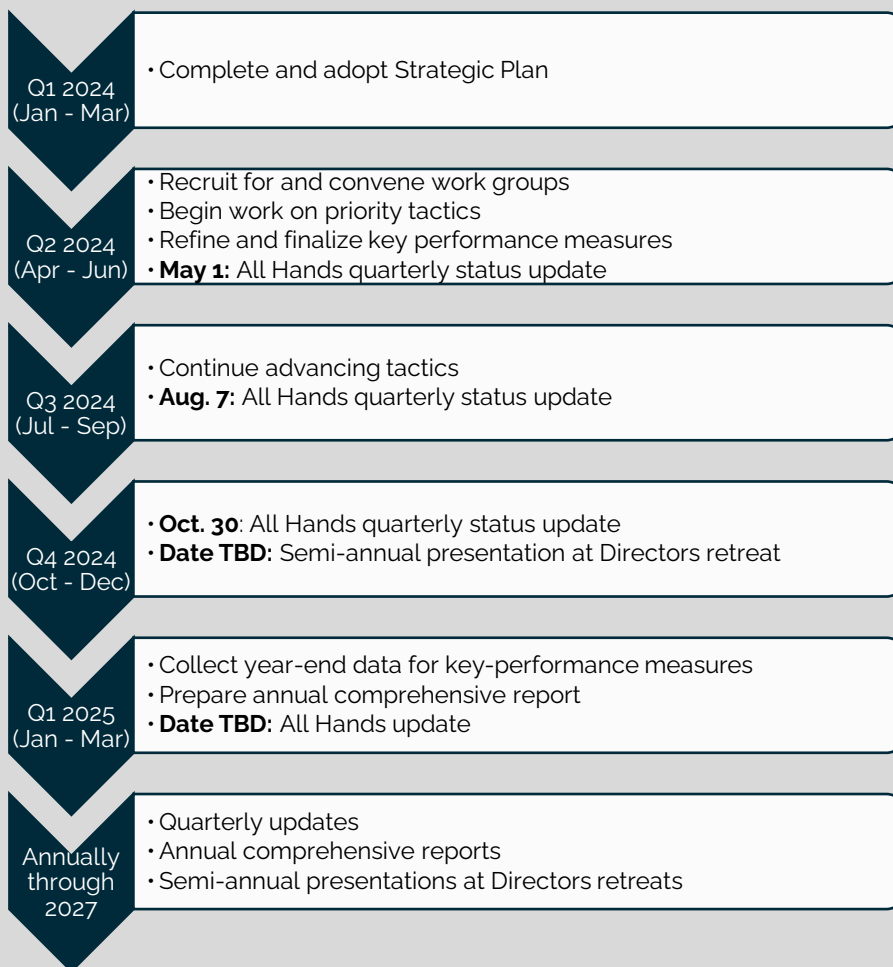

As its name suggests, this plan is about **momentum**. To sustain momentum, we must be willing to adapt to change and flexibly meet unforeseen challenges.

At each quarterly milestone, work groups may propose updates to Plan contents in response to changing conditions and needs. Any edits will be clearly documented and presented to all staff for consideration before finalizing.

MILWAUKIE ***MOMENTUM***

2024-2027 Organizational
Strategic Plan

Council Update
May 20, 2024





Why did we create a strategic plan?

- + Align community vision with city operations
- + Help navigate trade-offs and resource constraints
- + Tap into what makes people want to work for and stay at City of Milwaukie

Development Process

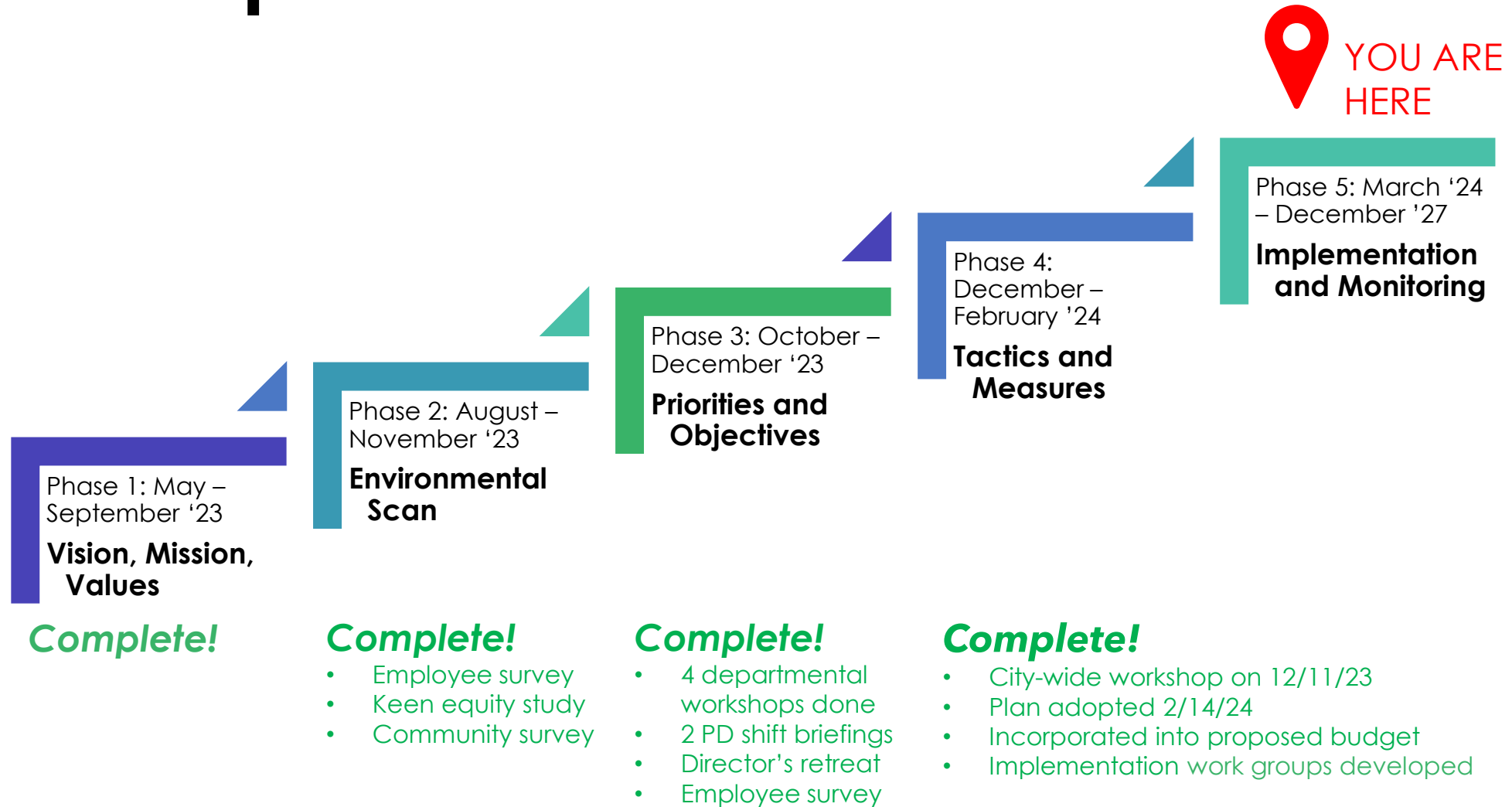

Team Milwaukie's NORTH STARS

VISION

Team Milwaukie is a **diverse and resilient** city government, **delivering effective public services** that make our community **a great place to be.**

MISSION

We **serve as stewards of our living and built environment** to help create a **safe and welcoming community for all**

VALUES

At the City of Milwaukie, we strive to be:

- **Accountable**
- **Accessible**
- **Efficient**
- **Collaborative**
- **Equitable**

2024-2027: Priorities and Objectives



Support our employees

Work smarter together

Revitalize Milwaukee

Help Milwaukeeans most in need

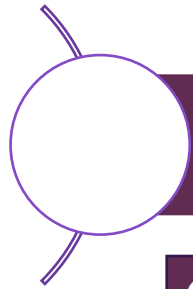

Support our employees

Objectives:

1A. Retain staff and promote career development

1B. Prioritize employee wellbeing

1C. Train staff to meet growing and changing demands

+ Example tactics:

Increase collaborative decision making in departments using values/priorities

Train managers on coaching skills

Document growth tracks for positions in multi-classification job families

Create coverage plans for periods of short staffing

Improve wellness and mindfulness resources available for staff (e.g., basketball hoop, fitness facilities, stretching rooms)

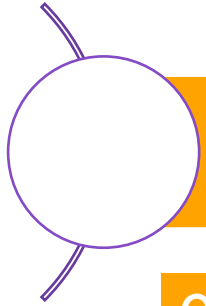

Work smarter together

Objectives:

2A. Review and improve technology and processes to better deliver services

2B. Improve collaboration and communication across departments and levels of the organization

2C. Coordinate public engagement to leverage resources and reach underrepresented voices

+ Example tactics:

Audit SOPs and identify critical gaps

Inventory software and hardware systems and make a forward-looking technology strategy

Create a stakeholder database that all staff can access

Hold trainings on critical software and implement intentional cross-training

Refresh the city website

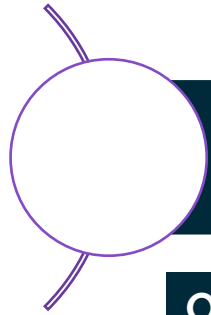

Revitalize Milwaukie

Objectives:

3A. Invest in our downtown and waterfront as part of the Urban Renewal Area

3B. Support economic development by fostering partnerships and neighborhood hubs

3C. Celebrate our unique community identity through city communications and events

+ Example tactics

Refresh the city's events program

Implement a youth engagement strategy

Connect local businesses to financial assistance and grant opportunities

Increase downtown safety and appeal

Create more outdoor covered spaces

Invest in Milwaukie Bay Park

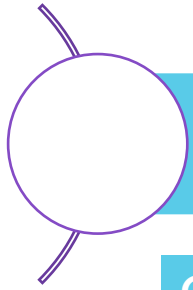

Help Milwaukians most in need

Objectives:

4A. Expand services for those experiencing crisis

4B. Use data to reduce barriers and invest where needs are the greatest

4C. Build relationships with organizations serving vulnerable communities

+ Example tactics:

Train staff on de-escalation and crisis management techniques

Support implementation of cooling, warming, and 23-hour stabilization centers

Build relationships with organizations serving Milwaukians of marginalized identities

Increase utilization of language access resources

Work groups launching this month!

Responsibilities include:

- Prioritizing tactics
- Tracking progress
- Troubleshooting roadblocks
- Making recommendations to leadership
- Refining and reporting on performance measures

Collaborating with implementation leads on all the above



Work group rosters

Department	Support our Employees Work Group	Work Smarter Together Work Group	Revitalize Milwaukie Work Group	Help Milwaukians Most in Need Work Group
<i>Group Sponsor</i>	Brandi Leos	Joseph Gardner	Joseph Briglio	Brent Husher
City Admin	Joyce White	Jon Hennington	Emilie Bushlen	Hannah Wells
Library	Fida Hurlock	Elysa Foxman	Melissa Perkins	Kelly Lamm
Community Development	Patrick McLeod	Josh Neath	Ben Green	Vera Kolas
Public Works	Tony Lairson	Peter Passarelli	Michael Harman	Kaleena Hughes
Public Safety	Brian Smith	Zane Odem	Kathryn Meier	Tim Cleary



Holding ourselves accountable:

Reporting strategy

- + **Quarterly:** Status updates at All Hands meetings
- + **Semi-annually:** Representatives of the work groups present recommendations at Directors' retreats
- + **Annually:** Comprehensive reports, including data for performance measures
- + **Ongoing:** All information published on the employee intranet

Questions for Council

- + How would you like to be involved in the work to develop equity performance indicators?
- + How frequently and in what format would you like updates on *Milwaukie Momentum*?